

**EFFECTS OF TILLAGE METHOD AND SOWING TIME ON
GROWTH, WATER USE AND YIELD OF CHICKPEA (*Cicer
arietinum L.*) IN KENYAN DRY HIGHLANDS**

BY

CHARLES A. NYAMBANE ONYARI



**A Thesis Submitted to the Graduate School in Partial Fulfillment of the
Requirements for the Degree of Master of Science in Agronomy
(Dryland Farming) of Egerton University**

2012/89211
M1268/2102

EGERTON UNIVERSITY LIBRARY



**Egerton University
October 2007**

DECLARATION AND RECOMENDATON

DECLARATION

This is to certify that this thesis is my original work and has not been presented to any other University for any degree or diploma.

Signature.....

Date: 24 / 10/2007

Charles Andrew Nyambane Onyari

RECOMMENDATION

This thesis has been submitted with our approval as University supervisors.

Signature.....

Date..... 26 / OCT/2007

Dr. A.M. KIBE

Department of Crops, Horticulture and Soil Sciences

Signature.....

Date..... 26 / 10/2007

Dr. J.P. OUMA

Department of Crops, Horticulture and Soil Sciences

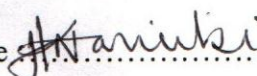
Signature.....

Date 29 / 10/2007

DR. J.N. KARIUKI

Animal Nutrition, Kenya Agricultural Research Institute - Naivasha

COPYRIGHT

All rights reserved. No work of this Thesis may be reproduced, stored in any retrieval system or transmitted in any form or by any means electronic, mechanical, photocopying, recording or otherwise without prior written permission of the author or Egerton University.

Copyright©CharlesNyambane2007

DEDICATION

This work is dedicated to my wife Elizabeth Bosibori and children Neliah Morah, Daniel Nyakundi, Faith Kerubo and Zeinabu Mong'ina for the support and patience they accorded me throughout the period I pursued the Masters Degree programme

EGERTON UNIVERSITY LIBRARY

ACKNOWLEDGEMENT

My deep gratitude go to Dr. Antony Mwangi Kibe, Agronomist and Lecturer, Department of Crops, Horticulture and Soil Sciences, Egerton University and principal supervisor of my project, for his valuable guidance, constructive criticism and thorough evaluation of this thesis. His contribution in this regard was paramount in making it possible for me to successfully complete my fieldwork and the compilation of this manuscript. He also gave his valuable time and guidance in the computation and interpretation of data, especially use of MSTAT computer package for the analysis of variance (ANOVA).

I wish to express my respect and thanks to Dr. Josephine P. Ouma, Agronomist and Lecturer, Department of Crops, Horticulture and Soil Sciences, Egerton University for her support in the drafting and editing of this thesis and introducing me to the use of SAS package for data analysis. Similar gratitude go to Dr. John N. Kariuki, Senior Research Scientist (and livestock nutrition), KARI-Naivasha for the valuable contribution of correcting and suggesting changes the written work.

Encouragement and valuable guidance in the initial drafting and organization of my research work by Professor Ngunjiri and Dr. Nyaanga, both of the Faculty of Engineering and Technology, Egerton University, the gracious provision of equipment by KARI-Njoro (Neutron Probe, also called depth moisture gauge), KARI-Naivasha (experimental site and weather data) and Mr. Ooro (leaf area meter), are gratefully acknowledged. Worth mentioning here also is Mr. Paul Kimurto of Egerton University who was instrumental in instructing me on the safe use of the depth moisture gauge and arranging with Canon Radiological Services for regular provision of radiation films for monitoring levels of exposure.

I express my gratitude to Dr. Ali, Senior Lecturer, Department of Mathematics, for his co-operation and guidance in the experimental design for this work.

My special thanks also go to Alice Songio Kosgey a colleague who availed her precious time to instruct me on the applications of SAS computer package for data analysis.

I gratefully acknowledge the help, encouragement and co-operation extended to me by staff members at the Ministry of Agriculture, colleagues, and friends at my work place, Egerton University, KARI-Naivasha and KARI-Njoro and beyond who are far too numerous to mention here. Moral support through prayers and words of encouragement by fellow Muslim brothers and sisters at Nakuru and Kirinyaga made a lot of difference and is gratefully appreciated.

I take this opportunity to thank P.G. School, Egerton University, for their supportive co-operation during my course of study.

I thankfully acknowledge the financial assistance rendered by Research and Extension Department through the principal supervisor, Dr. Antony Mwangi Kibe. Thanks are due to the Department of Personnel Management (DPM), Office of the President, through the Ministry of Agriculture (MoA) for granting me study leave in order to pursue the Masters Programme.

Gratitude is also due to my immediate family members who supported and encouraged me throughout this laborious work, especially my wife and children who patiently waited with unconditional love. May God Almighty bless them.

Nakuru

Copyright 15th January 2007

Charles Andrew Nyambane Onyari

ABSTRACT

The need to provide sufficient protein food for an increasing population that is mainly resource poor requires opening up of marginal land for growing appropriate pulses such as chickpea. An experiment was carried out at KARI-Naivasha situated at an altitude of 1900 m, characterized with clayey to sandy loam soils in a split plot of randomized complete block design over two seasons (December 29, 2004 to May 26, 2005 and June 21 to November 15, 2007). The objective was to investigate the production of *kabuli* chickpea in Kenya as affected by tillage methods (main plots) and sowing times (subplots) and the effects of these factors on water use and yield of the crop. The overall mean height ranged from 39.7 to 47.7 cm under tillage methods with strip tillage resulting in relatively taller plants than the other tillage methods. Sowing times gave plant heights of 41.5 – 46.4 cm with early sown crops being relatively taller than late sown crop in both seasons. The leaf area index ranged from 2.50 to 3.31 and 4.22 to 5.44 under tillage methods in Season I and II, respectively. The corresponding values of LAI in the respective two seasons under sowing times were 2.80 to 3.20 and 3.59 to 5.69. The crop took 32.5 to 35.5 days to first flower and 61.8 to 61.4 days to 50% flowering in Season I and II, respectively. The mean time to physiological maturity was 120 days showed significant differences among tillage methods in both seasons. The time to first flower and 50% flowering however had non-significant differences ($P < 0.05$) under both tillage method and sowing time treatments. The aboveground biomass yield of the chickpea varied from 3242.1 to 4231.3 kg ha⁻¹ in Season I and 3035.8 to 4556.1 kg ha⁻¹ in Season II under varying tillage treatments. The sowing time effects on biomass yield showed significant differences in biomass yields ranging between 3784.3 to 4095.0 kg ha⁻¹ and 2938.1 to 4263.2 kg ha⁻¹ in Season I and II, respectively. The grain yields obtained were significantly different ($P < 0.05$) ranging from 1430.6 to 2544.9 kg ha⁻¹ under tillage method effects and 1573.8 to 2235.3 kg ha⁻¹ under sowing time treatment effects in both seasons. Tillage and sowing time effects on grain yield of chickpea were significantly different ($P < 0.05$) only in the second season. In Season I, rains received in the post anthesis period of the chickpea thus causing it to exhibit indeterminate growth habit which resulted in additional yield increments of between 26.2 to 29.8% and 23.3 to 35.0% under various tillage and sowing time treatments, respectively. This gave a final overall mean grain yield of 2058.4 kg ha⁻¹. The 100-grain weight of the chickpea varied between 36.7 to 40.2 g in both seasons and showed non-significant differences under both factors of study. Infiltration rates were not significant under tillage and sowing times but affected the storage capacity ranging between 450.3 mm for first sowing time in Season II to 488.1 mm for conventional tillage in Season I. The mean seasonal evapotranspiration varied between 300.1 mm to 326.1 mm and showed interaction effects between tillage and sowing times in Season II. The mean biomass based water use efficiency (WUE_b) and grain based water use efficiency (WUE_g) ranged from 12.09 to 12.21 kg ha-mm⁻¹ and 4.93 to 6.31 kg ha-mm⁻¹ in Season I and II, respectively. The moisture use rate was non-significant with ranges of 2.23 to 2.58 and 2.18 to 2.56 mm/day in Seasons I and II, respectively.

TABLE OF CONTENTS

DECLARATION AND RECOMENDATON	ii
DECLARATION	ii
COPYRIGHT	iii
DEDICATION	iv
ACKNOWLEDGEMENT	v
ABSTRACT	vii
TABLE OF CONTENTS.....	viii
LIST OF TABLES	xii
LIST OF FIGURES	xiii
CHAPTER ONE	1
1.0 INTRODUCTION	1
1.1 Background Information.....	2
1.2 Statement of the Problem.....	2
1.3 Justification	2
1.4 Objectives	2
1.5 Research Hypotheses	3
CHAPTER TWO	4
2.0 LITERATURE REVIEW	4
2.1 Introduction.....	4
2.2 Infiltration Rates.....	6
2.3 Effects of tillage methods on infiltration rates.....	6
2.4 Effects of tillage on growth and yield of chickpea.....	8
2.5 Effects of tillage on water use efficiency.....	9
2.6 Effects of sowing time on growth and yield of chickpea.....	9
2.7 Interactive methods of tillage methods and sowing times.....	11
CHAPTER THREE	12
3.0 MATERIALS AND METHODS.....	12
3.1 Location and weather conditions.....	12
3.2 Soil.....	12
3.3 Experimental Design and Layout.....	13

3.4 Weather Data Collection and Graphs.....	13
3.5 Crop Establishment and Management.....	13
3.6 Data Collection.....	16
3.6.1 Plant Sampling.....	16
3.6.2 Plant Height.....	16
3.6.3 Flowering.....	17
3.6.4 Leaf Area Index.....	17
3.6.5 Biomass and Grain Yield.....	17
3.6.6 Volumetric water content measurement and installation of access tubes.....	18
3.6.7 Evapotranspiration.....	20
3.6.8 Field Capacity and Bulk Density.....	21
3.6.9 Infiltration Rate.....	21
CHAPTER FOUR.....	23
4.0 RESULTS.....	23
4.1 Growth attributes.....	23
4.1.1 Plant height.....	23
4.1.2 Leaf Area Index.....	25
4.1.3 Total above-ground biomass.....	27
4.1.4 Flowering and Maturity.....	31
4.2 Yield Attributes and Grain Yield.....	35
4.2.1 Number of Branches / Plant.....	35
4.2.2 Number of pods per plant.....	37
4.2.3 Grain yield of chickpea.....	39
4.2.4 100-Grain weight of <i>kabuli</i> chickpea.....	41
4.3 Soil Moisture Use by chickpea.....	42
4.3.1 Soil Moisture Infiltration.....	42
4.3.2 Soil water storage.....	44
4.3.3 Profile moisture storage over time.....	47
4.3.4 Seasonal Evapotranspiration of Chickpea.....	50
4.3.5 Water Use Efficiency of Chickpea (Biomass Basis).....	56
4.3.6 Water Use Efficiency (Grain yield basis).....	57

4.3.7 Moisture use rate by chickpea.....	60
CHAPTER FIVE	62
5.0 DISCUSSION	62
5.1 Chickpea growth under varying tillage methods and sowing times.....	62
5.1.1 Chickpea growth attributes under varying tillage methods.....	62
5.1.2 Chickpea growth attributes under varying sowing times.....	62
5.2 Effects of tillage methods and sowing times on chickpea maturity attributes.....	64
5.2.1 Time to first flower.....	64
5.2.2 Time to 50% flower.....	65
5.2.3 Time to physiological maturity.....	65
5.3 Yield and yield attributes of kabuli chickpea.....	66
5.4 Effects of tillage method on infiltration rate.....	67
5.5 Effects of tillage and sowing time on soil moisture storage.....	68
5.5.1 Soil moisture storage under varying tillage methods.....	69
5.5.2 Soil moisture storage under varying sowing times.....	70
5.6 Evapotranspiration-Yield relationship under varying tillage and sowing dates.....	71
5.7 Tillage method and sowing time effects on water use efficiency by chickpea.....	75
5.8 Effects of tillage method and sowing times on moisture use rate.....	75
CHAPTER SIX.....	76
6.0 CONCLUSIONS AND RECOMMENDATIONS	76
6.1 CONCLUSIONS.....	76
6.2 RECOMMENDATIONS.....	76
REFERENCES	77
APPENDIX I: Relative humidity (%), temperature ($^{\circ}\text{C}$) and gust (km h^{-1}).....	85
APPENDIX II: Rainfall (mm) distribution at KARI-Naivasha in 2005.....	87
APPENDIX III: Effects of tillage methods on plant height of kabuli chickpea grown at KARI-Naivasha in Season I and II	88
APPENDIX IV: Effects of sowing times on plant height of <i>kabuli</i> chickpea grown at KARI-Naivasha in Season I and II	88
APPENDIX V: Effects of tillage methods on leaf area index of kabuli chickpea grown at KARI-Naivasha in Season I and II	89

APPENDIX VI: Effects of sowing time on leaf area index grown of kabuli chickpea
grown at KARI-Naivasha in Season I and II 89

APPENDIX VII: Effects of tillage methods on the total number of branches per plant of
kabuli chickpea grown at KARI-Naivasha in Season I and II 90

APPENDIX VIII: Effects of sowing times on the total number of branches per plant of
kabuli chickpea grown at Naivasha in Season I and II 90

APPENDIX IX: Extracts from ANOVA tables showing means of select growth and yield
parameters for *kabuli* chickpea grown at KARI Naivasha in Season I and II under
different tillage methods and sowing times 91

LIST OF TABLES

Table 1 Mean values of relative humidity, temperature (°C) and gust (km/h) at the experimental site (KARI-Naivasha) during chickpea growth	13
Table 2 Rainfall amount per growth phase of <i>kabuli</i> chickpea (days after sowing) under different sowing times at KARI-Naivasha in Seasons I and II	15
Table 3 Mechanical composition of the soil the experimental site at KARI-Naivasha	15
Table 4 Physical constants of the soil at the experimental site	15
Table 5 Effects of tillage method and sowing time on plant height (cm) of <i>kabuli</i> chickpea at different times of growth at KARI-Naivasha in Seasons I and II	24
Table 6 Effects of tillage methods and sowing times on the leaf area index (m ² m ⁻²) of <i>kabuli</i> chickpeas grown at KARI-Naivasha in Seasons I and II	26
Table 7 Effects of tillage method and sowing time on total aboveground dry matter biomass of <i>kabuli</i> chickpea at different times of growth at KARI-Naivasha in Season I and II	29
Table 8 Effects of tillage method and sowing time on maturity times (days after sowing) of the <i>kabuli</i> chickpea grown at Naivasha in Seasons I and II	32
Table 9 Tillage method and sowing interactive effects on the time (days after sowing) for <i>kabuli</i> chickpea to reach physiological maturity in Season II	34
Table 10 Effects of tillage method and sowing time on mean cumulative numbers of branches per plant of <i>kabuli</i> chickpea grown at KARI-Naivasha in Season I and II 36	36
Table 11 Effects of tillage method and sowing time on the number of pods/plant, 100-grain weight and grain yield of <i>kabuli</i> chickpea grown KARI-Naivasha in Seasons I and II	38
Table 12 Effects of tillage method and sowing time on the soil infiltration capacity and rates for the Naivasha soils grown with <i>kabuli</i> chickpea in Seasons I and II	43
Table 13 Effects of tillage method and sowing time on total soil moisture storage (mm) in the 110 cm soil profile at different growth stages of <i>kabuli</i> chickpea	45
Table 14 Percent profile soil moisture content during the growth of <i>kabuli</i> chickpea growth at the KARI-Naivasha in Season I and II	48
Table 15 Effects of tillage methods and sowing times on seasonal evapotranspiration of chickpea grown at KARI-Naivasha in Season I and II	52
Table 16 Interactive effects of tillage method and sowing time on the seasonal evapotranspiration of <i>kabuli</i> chickpea in Season II	55
Table 17 Effects of tillage method and sowing time on water use efficiency (biomass basis, kg/ha-mm) of <i>kabuli</i> chickpea grown at the KARI-Naivasha in Seasons I and II	58
Table 18 Effects of tillage methods and sowing times on grain water use efficiency (kg ha-mm ⁻¹) and moisture use rate (mm/day) of <i>kabuli</i> chickpea grown at Naivasha in Seasons I and II	61

LIST OF FIGURES

Figure 1 Layout plan of the experiment.....	14
Figure 2 Effects of tillage methods on aboveground dry matter biomass of chickpea grown at KARI-Naivasha in Season I and II	30
Figure 3 Effects of sowing times on aboveground dry matter biomass of chickpea grown at KARI-Naivasha in Season I and II	30
Figure 4 Effects of tillage methods on grain yields (133 DAS) <i>kabuli</i> chickpea grown at KARI-Naivasha in Seasons I and II.....	40
Figure 5 Effects of sowing times on grain yields (133 DAS) <i>kabuli</i> chickpea grown at Naivasha in Seasons I and II.....	40
Figure 6 Effects of tillage methods on soil moisture storage during chickpea growth at Naivasha in Seasons I and II.....	46
Figure 7 Effects of tillage methods on soil moisture storage during chickpea growth at Naivasha in Seasons I and II.....	46
Figure 8 Moisture distribution per unit depth of soil at Naivasha during the growth of <i>kabuli</i> chickpea in Seasons I and II.....	49
Figure 9 Effects of tillage methods on seasonal evapotranspiration of <i>kabuli</i> chickpea grown at Naivasha in Seasons I and II.....	53
Figure 10 Effects of sowing times on seasonal evapotranspiration of <i>kabuli</i> chickpea grown at Naivasha in Seasons I and II.....	53
Figure 11 Effects of tillage methods on water use efficiency biomass basis of <i>kabuli</i> chickpea grown at Naivasha in Seasons I and II.....	59
Figure 12 Effects of sowing times on water use efficiency biomass basis of <i>kabuli</i> chickpea grown at Naivasha in Seasons I and II.....	59
Figure 13 Crop evapotranspiration-biomass yield relationship for <i>kabuli</i> chickpea under varying tillage methods in Season I.....	73
Figure 14 Crop evapotranspiration-biomass yield relationship for <i>kabuli</i> chickpea under varying tillage methods in Season II.....	73
Figure 15 Crop evapotranspiration-biomass yield relationship for <i>kabuli</i> chickpea under varying sowing times in Season I	74
Figure 16 Crop evapotranspiration-biomass yield relationship for <i>kabuli</i> chickpea under varying sowing times in Season II	74

CHAPTER ONE

1.0 INTRODUCTION

1.1 Background Information

Semi arid areas are characterized by low rainfall events with high evaporative losses, making moisture availability the most limiting factor for crop production (Berliner *et al.*, 2000; Harris *et al.*, 2000). These areas have high evapotranspiration rates due to high temperatures and receive between 250-800mm of rainfall annually. Such weather conditions influences plant biomass and grain yield productions which are known to directly influence by plant water uptake and thus evapotranspiration (Saxena, 1984; Schultz, 1986; Kibe and Singh, 2002). Inability to properly manage the limited precipitation is as much a problem as is the limited resource (Shedrake and Saxena, 1979). Due to increasing population, demand for food will require an increase in crop production per unit area, which would exert pressure on soil moisture and fertility (Feitelsen, 2000). The National Census estimated Kenya's population growth rate at 2.9%, indicating that demand for food will steadily increase in the future (Anon, 1997). However, only 17% of the 58.8 million hectares of Kenyan land is suitable for crop production. Further increase in food production will therefore either come from increase in yield per unit area or expansion of cultivated land in the arid and semiarid regions. Technologies such as appropriate tillage practice and sowing time are needed to provide farmers with optimum crop yields through reduced runoff flow and increased soil water storage for crop use (Chevalier *et al.*, 1993; Cessman, 2001).

Chickpea (*Cicer arietinum* L.) is a hardy crop grown with residual moisture and on marginal soils that are unsuitable for crops such as wheat (Saxena, 1984). In the early stages of growth most of the roots are confined to the surface layer of soil from 0-30cm depths. As the surface soil dries out, root growth continues to deeper layers, where significant moisture is available (Sheldrake and Saxena, 1979). On the basis of cultivated area, it is the nineteenth most important crop and is grown in thirty-four countries of the world. India, Pakistan, Bangladesh, and Nepal where it is the most important grain legume, grow 90% of the world hectareage. It is also an important crop in northern Africa and is grown in parts of North and South America (ICRISAT, 1987).

Research data on the effect of water available to chickpea under different tillage systems in Kenya is not available. The objective of this research is to study the influence of tillage method, sowing time and their interaction on the moisture use and yield of chickpea in a dry highland environment in Kenya's Rift Valley province.

1.2 Statement of the Problem

- The dry lands regions experience high evaporative demands that leads to lose of the limited stored soil moisture which leads to crop failure.
- Kenyan dry highlands are characterized by scarce, erratic and abharent rainfall, resulting in low soil moisture & crop desiccation.
- Soil moisture conservation strategies are yet to be studied, understood and applied in Kenyan dry areas.
- The productivity of chickpea (*Cicer arietinum*), has not yet been evaluated for the Kenyan dry highland conditions.

1.3 Justification

Chickpea is a major food legume and an important source that can grow on residual soil moisture and matures early compared to the traditional pulses such as pigeon pea and cowpea while the common bean cannot survive in marginal area.. Soil water is a limited resource that needs to be conserved and used efficiently for crop production, particularly in the semi-arid regions of Kenya. Tillage operations that increase infiltration and soil moisture storage and sowing times that enhance efficiency of rain water utilization by the crop need to be studied for purposes of increasing grain legume production. Tillage practices and sowing times for *kabuli* chickpea cultivation in Kenya, their effectiveness in moisture conservation and relationship with chickpea yields were therefore tested as they are critical to realizing good performance of this relatively new crop in Kenya.

1.4 Objectives

The broad objective was to enhance chickpea production in Kenya through timely sowing and appropriate tillage management practices.

The specific objectives were to determine:

- (a) the effect of tillage method on growth, water use and yield of chickpea,

- (b) the effect of sowing times on growth, water use and yield of chickpea,
- (c) the interactive effects of tillage method and sowing time on growth, water use and yield of chickpea, and,
- (d) the effect of tillage method on infiltration rates.
- (e) the effects of sowing times on infiltration rates.

1.5 Research Hypotheses

- (a) There is no difference on growth, water use and yield of chickpea among tillage methods.
- (b) There is no difference on growth, water use and yield of chickpea among sowing times.
- (c) Tillage method and sowing times have no interactive effects on growth, water use and yield of chickpea.
- (d) There is no difference in infiltration rates among tillage methods.
- (e) There is no difference in infiltration rates among sowing times.

CHAPTER TWO

LITERATURE REVIEW

2.1 Introduction

Interest in dryland and rainfed farming systems has increased significantly in recent years in many regions of the world because of rapidly increasing human populations coupled with low productivity gains, escalating water development costs for new irrigation projects, and high operational and maintenance costs associated with irrigated agriculture (Steiner *et al.*, 1988). Dryland agriculture emphasizes water conservation, sustainable crop yields, limited inputs for soil fertility maintenance, and management of wind and water erosion. Oram (1980) defines dryland farming as husbandry under conditions of moderate to severe moisture stress during a substantial period of the year, which requires special cultural techniques and adapted crops and systems for successful and stable agricultural production. Dry lands are low total rainfall with at least one pronounced dry season (and sometimes two) so that lack of moisture puts a ceiling on year-round cropping even though it may be adequate for one crop (Oram, 1980). Others are highly variable and unreliable precipitation during the rainy season, increasing unreliability and variability with decreasing annual rainfall, potential evapotranspiration exceeding precipitation for at least seven months of the year; very high intensity rainstorms leading to high runoff and erosion.

Kenya is among 64 countries with inadequate rainfall and is classified in category II that consist mainly of African countries along with Afghanistan, Jordan and Syria (FAO, 1974). The country consists of over 80% land as semi arid to arid. Soils in the dryland areas range from sandy, shallow, low-fertility to highly productive medium- to fine-textured, deep soils (Dregne, 1982). Although low soil water levels commonly restrict crop yields in dry areas, other problems such as surface soil hardening and compaction by tillage implements, susceptibility to water and wind erosion, low fertility, shallowness, stoniness, restricted drainage, and salinization also affect crop production (Steiner *et al.*, 1988). Therefore, soil and water conservation measures will increase water use efficiency, conserve soils and its fertility so as to increase and sustain crop yields.

Chickpea is usually grown after the rainy season on stored soil moisture during winter in

India and in spring in temperate and Mediterranean regions with 80% of the area under rainfed. Recently, chickpea has been grown in the temperate and Mediterranean regions as a winter crop when rainfall is well distributed over the growing season (Saxena, 1976). The water use efficiency (WUE) of non-fertilized chickpea crops grown on stored water at ICRISAT Centre, Patancheru, was shown to be between 7.6 and 9.2 kg grain ha-mm⁻¹ of evapotranspired moisture (Saxena, 1984). The Centre reported the crop to grow extensively as a sole crop in black soils on stored soil moisture. The available moisture in black soils ranges from 135 to 300 mm m⁻¹ depth during the growing season (23 weeks) depending on the soil depth which can hardly sustain a good sole crop of chickpea (ICRISAT, 1987). The water requirements were however reported by Sharma *et al.* (1989) to vary from 204-280mm. Guto (1997) noted that the introduction of chickpea (*Cicer arietinum*) in Kenya as a food security crop was based on its early maturing habit and ability to survive under low moisture supplies.

Jordan *et al.* (1990) defined water use efficiency (WUE) as a ratio of biomass accumulation, expressed as carbon dioxide assimilation (A), total crop biomass (B), or crop gain yield (G) to water consumed expressed as transpiration (T), evapotranspiration (ET), or total water input system (i). The time scale for defining water use can be instantaneous (i), daily (d), or seasonal (s).

$$\text{WUE (G, ET, s) or WUE (A,T,i)}$$

The most commonly used definition of water use efficiency was given by Viets (1962) as the ratio of the weight produced (Y) to the evapotranspiration rate (ET).

$$\text{WUE} = Y \text{ (kg ha}^{-1}\text{)}/\text{ET (mm)}$$

Quite often the yield (Y) or dry matter produced is referred mainly to grain. Stanhill (1966) gave a more meaningful hydrological definition of WUE as the ratio between the volumes of water productively used to the volume of water potentially available for the process. Potential availability naturally includes the whole rainwater and the water already stored in the soil before sowing of the crop (Hedge, 1995). Agronomic practices for reducing evaporation from the soil surface and those for increasing water supply to plants are said to improve WUE (Gregory, 1988).

Growth of plants and its subsequent yield (biomass or grain) can be estimated accurately

using the leaf area index (LAI), which is the leaf area per unit land surface the plant is occupying (Saxena, 1984). Working on durum wheat Aparicio *et al.* (2000) found out that LAI was the crop growth trait that most closely related with other factors such as spectral reflectance indices for the assessment of growth and yield. Swanson and Wilhelm (2000) showed that sowing maize before or after the optimum date decreased LAI, leaf area duration, total dry matter production and grain yield. During the middle life of a crop the rate of leaf senescence may be approximately balanced by the rate of production of new leaf area so that LAI is fairly constant even though the leaf canopy is changing quantitatively (Saxena, 1984). At optimum LAI, however, the crop growth rate no longer responds to increasing LAI.

2.2 Infiltration Rates

Mayande (1995) reported two possible ways of increasing the total volume of water infiltrated under rainfall: an increase of the surface storage or an increase in the infiltration rate. Large amounts of rainfall are lost through runoff in arid and semiarid regions owing to surface sealing which is considered a major cause of low infiltration (Lemos and Lutz, 1957; Connolly *et al.*, 1998). They further noted that soil crusts have prominent effects on a number of soil phenomena, reducing infiltration and slowing soil-atmosphere gas exchange among others. A reduction in infiltration rate adversely affects efficiency of rainfall or irrigation (Al-Qinna and Abu-Awwad, 1998). These researchers showed that crusted soils tend to generate large runoff even at small application rates of water in form of irrigation or rainfall.

2.3 Effects of tillage methods on infiltration rates

A major focus of dryland cropping systems is to increase efficient water use with minimum losses to evaporation, drainage and runoff (Parr *et al.*, 1990; Hedge, 1995). This involves maintaining soil characteristics favorable for rapid infiltration of precipitation and retaining the water in the soil profile, cropping at a time when the rooting intensity is appropriate to use both seasonal precipitation and stored soil water. Infiltration can be calculated from the change in soil water storage measured using a neutron probe before and after rainstorms (Gaze *et al.*, 1997).

Cultural practices such as tillage (conventional ploughing, chiseling and furrow dicing) help reduce runoff and capture rainwater hence improve soil water storage by enhancing infiltration (Hedge 1995; Sow *et al.*, 1996). Work by Salih *et al.* (1998) showed that subsoiling did not significantly increase the infiltration rate. But subsurface tillage, which results in most of the surface residues remaining on the surface, increases infiltration among other benefits (Steiner *et al.*, 1988). In water-deficit farming areas, contour furrowing for row crops is an effective runoff control and water conservation technique. Contouring with terracing often reduces runoff more than terracing alone because the contour furrows hold the water on a major portion of a field, each serving as a miniature terrace when a lister or disc bedder is used (Jordan *et al.*, 1990). Ploughing followed by harrowing gave the highest infiltration rate of 5.79 cm h^{-1} compared to when it was used alone or the two treatments were followed by bedding (Afolayan *et al.*, 2004).

A frequent problem in many soils is the sealing or partial sealing of the soil surface due to crust formation, tending to reduce both sorptivity and conductivity of the soil; erratic rainfall also complicates the infiltration process (Reeves and Miller, 1975). Conservational tillage systems that leave crop residues on the surface of the soil have been studied and applied to minimize the adverse effects of fallow and to increase the efficiency of soil water storage (Steiner *et al.*, 1988). Use of no-till production methods improves precipitation storage efficiency and soil water availability, which allow for more intense and diversified cropping systems (Anderson *et al.*, 1999; Nielson *et al.*, 1999). El-Swaify *et al.* (1985) showed that only about 40% of the total rainfall was used for evapotranspiration during the growing season and more than 25% was lost as runoff. Deep percolation losses were low in vertisols (9.5%) compared to 33% in alfisols. Tillage can therefore be seen to modify the soil profile by increasing infiltration and distribution of soil water, thus enabling crop roots to access more moisture. Connolly *et al.* (1998) reported that appropriate tillage and cover management are required to maintain high infiltration rates. Measurements of infiltration rates in clay loam soil with low organic matter content were compared under zero tillage, conventional tillage and deep tillage (Shafiq *et al.*, 1994). The results showed that the cumulative intake and intake rates were

significantly higher in the zero tillage treatments as the vegetative cover in them reduced the incidence of crust conditions.

2.4 Effects of tillage on growth and yield of chickpea

Tillage refers to the different mechanical manipulations of the soil used to provide the necessary soil conditions favourable to the growth of crops whereas tillage is the physical condition of the soil in its relation to plant growth (Hedge, 1995). Chickpea is commonly believed to be a hardy crop grown on marginal soils not suitable for crops such as wheat since it is known to possess a deep taproot system with three to four well defined rows of lateral roots (Fisher and Goldworthy, 1984). In the early stages of growth most of the roots are confined to the surface layer of soils from 0 to 30cm depth but continue to develop into deeper layers as the surface layer of the soil dries out. For hard-setting soils reduced tillage and stubble retention systems are more beneficial financially (ACA, 2004). Deep tillage or sub-soiling can be used to enhance axial root growth of chickpea by reducing soil strength (Allmaras *et al.*, 1998). Bulk density of the plough pan at 135 days after sowing accounted for 90% of the observed variation in subsoil root dry weight while soil penetration resistance accounted for 59% of the variation (Gaze *et al.*, 1997).

Tillage management therefore affects growth of chickpea, both below and above the soil surface, by affecting root growth and extraction of soil water for plant use. Such effects need to be studied for chickpea growing under Kenyan conditions.

Harris *et al.* (2000) reported that the strongest determinant of seed yield for chickpea and lentil and their water use under rainfed conditions is rainfall and its distribution. Results for chickpea grown under three levels of limited irrigation showed that the crop experiences terminal drought stress starting between flowering and beginning of seed growth. This terminal drought severely reduced grain yield by 67%, from 2766 kg ha⁻¹ under full irrigation conditions to 909 kg ha⁻¹ under rainfed conditions (Soltani *et al.*, 2001).

The effects of tillage practice (conventional tillage [CT] and no-till [NT]) were shown to be variable depending on the growth stage (Birch *et al.*, 1996). At harvesting NT plots

produced greater total dry matter (4.20 ton ha^{-1}) and seed yield (1.94 t ha^{-1}) than CT plots (3.01 and 1.29 ton ha^{-1}). No-till production can significantly increase yields over conventional practices and, when combined with rotation cropping pattern, offers the greatest potential for yield increases over traditional practices as shown for cotton growing (Bordovsky *et al.*, 1994).

2.5 Effects of tillage methods on water use efficiency

Water use efficiency is positively correlated with root mass and length while depth of root system influences uptake and utilization of soil available water (Eghball and Maranville, 1993). Work by Salih *et al.* (1998) showed that subsoiling increased water use efficiency by 25% and 13% over disc harrowing and disc ploughing respectively.

Mwendera and Feyen (1997) reported that the drying characteristics of tilled soils were influenced by factors such as tillage depth and the nature of evaporative demand. Tillage induced open surface structure reduces evaporation at higher evaporative demands (Mwendera and Feyen, 1994). Research work by Bordovsky *et al.*, (1994) found that no-till production systems significantly increased yields over conventional systems for cotton. Furrow tillage and no-tillage treatments reflected a more efficient use of soil water in sorghum yield (Salih *et al.*, 1998). Work on the effects of tillage on water use efficiency by chickpea seems not to have been documented and, therefore, require determination and documentation for Kenyan dryland conditions.

2.6 Effects of sowing time on growth and yield of chickpea

Since chickpea is sown on stored soil moisture, there is every likelihood that the crop may face short spells of drought during the growing season, if the moisture at sowing time is inadequate or if winter rains fail (Saxena, 1976). When compared to post-rainy season crops, chickpea is better adapted to drought stress situations as illustrated by its stable performance over years at Hisar, India, where the overall productivity of the crop was higher than that of mustard and safflower (ICRISAT, 1987). This report postulated that productivity of chickpea could therefore be predicted from the stored soil moisture at sowing time plus growing season rains. It added that temperature and evaporative demand during the growing season, however, should be taken into account.

It has been observed that an early sown crop of chickpea on fertile soil often attained excessive growth and yielded poorly due to lodging and the high incidence of diseases (ICPN, 1994). The report noted that results based on two different types of soils (loamy sand and sandy loam) showed that the time of sowing had a significant effect on the production of chickpea. If the crop is sown late (for rainfed or irrigated conditions), yield losses could be avoided by using a higher seed rate.

A two-year study to examine the effect of sowing time and tillage practices on chickpea production parameters such as grain and dry matter yield showed that sowing time affects these parameters (Birch *et al.*, 1996). This showed that early sowing ensures more favourable conditions for chickpea. Thomas and Hammer (1995) reported that the differences in the patterns of change in soil moisture content with time between barley and chickpea depend on growing conditions. Their study showed susceptibility of chickpea to low temperatures that cause poor root growth, resulting in differences in the efficacy of utilizing extracted water to produce biomass. Examination of water relations of chickpea and dry pea revealed ability of these crops to grow at lower water contents than spring wheat, and had high WUE values similar to it (Miller *et al.*, 2002). Work by Anwar *et al.* (2002) reported grain water use efficiency ranging from 5.8 – 11.7 kg ha⁻¹ mm⁻¹.

Work in Australia by Birch *et al.* (1996) showed that greater dry matter yield and seed yield of chickpeas (4.18 to 5.95 and 1.63 to 2.25t ha⁻¹) resulted from sowing in autumn or early winter than sowing in late winter (3.39 to 3.86 and 0.97 to 1.22 t ha⁻¹). Dalal *et al.* (1997) reported that late winter (May-June) sowing time was the best for chickpea yield and nitrogen fixation since it optimized solar energy use and water use and minimized frost damage at Warra, Australia. At the time of maximum dry matter yield, yield was higher under conventional tillage for autumn sowings and under no-till for winter sowings.

Chickpea is a major food legume and an important source of protein in many countries in Asia and Africa yet its productivity continues to be low at 0.78 t ha^{-1} (Upadhyaya *et al.*, 2001). Bejiga *et al.* (1997), working in Ethiopia, showed that varying sowing dates for chickpea affect yield. They indicated that early sowing increased yield of seed by 9.5% to 48% at Debre Zeit and 17.4% to 45% at Akai as compared to the third sowing date of late August.

Short rains (March-April) trials in Uganda locations between 1400 to 2500m above sea level showed that cool dry weather with a fully charged soil profile favoured crop growth; yields of 2 to 2.5 t ha^{-1} were obtained and the crop matured in 90 to 100 days after sowing (ICRISAT, 1993). For trials conducted at Kibwezi, Kenya, yields of chickpea lines ranged from 2 to 3 t ha^{-1} . Among the determinate lines used were ICPL90011 and ICPL88017 while those of non-determinate lines were ICPL88032 and ICPL90031. The report further said that at Kiboko entries in the determinate lines did not yield as much as at Kibwezi but the main yields of non-determinate lines were better than those of determinate lines. The determinate lines did very well at Kiboko with ICPL87109 yielding 5.65 ton ha^{-1} while ICPL86005 and ICPL90029 yielded more than 4.40 ton ha^{-1} (ICRISAT, 1987; ICPN, 1994). These findings indicate that time of sowing of crops such as chickpea affects yield.

2.7 Interactive effects of tillage method and sowing time

Dalal *et al.* (1998) reported that early to mid sowing of the crop accompanied by zero tillage practice could enhance beneficial effects of chickpea in rotation with cereals. In a study to examine the performance of chickpea in a chickpea-wheat rotation, mean values of WUE for seeds were $5.9 \text{ kg ha-mm}^{-1}$. Sowing time had a much large effect on seed yield and nitrogen fixation by chickpeas than tillage practices (conventional and zero tillage) although zero tillage generally increased grain yields (Dalal *et al.*, 1997). They concluded that early sowing time and zero tillage practice, possibly combined with more appropriate cultivars, could enhance chickpea biomass. Birch *et al.* (1996) observed that significant interaction between sowing time and tillage resulted in greater grain yield than that obtained from zero tillage than conventional tillage methods.

CHAPTER THREE

3.0 MATERIALS AND METHODS

Field experimentations were carried out at Kenya Agricultural Research Institute based at Naivasha, Rift Valley Province, Kenya, over two seasons starting December 29 2004 to May 2005 (Season I) and June to November 2005 (Season II), to investigate the effects of tillage method and sowing time on the water use and yield of *kabuli* chickpea.

3.1 Location and weather conditions

The National Animal Husbandry Research Centre, Naivasha, (NAHRC) is located at 1900m above sea level on a grid of 0° 40'S and 36° 26'E. The area receives a total average of 620mm bimodal rainfall annually, with 60% reliability. The long rains season starts in March through June while the short rains come in September to November. The rains are generally erratic with no definite incidence period, some rains coming in months when least expected. The diurnal temperatures range between 16-28°C and nocturnal being 8-18°C while the relative humidity varies between 60-75% (Jaetzold and Schmidt, 1983). The actual site was at Lower Farm, one of the three-constituent farms of the research centre. The maximum relative humidity (%RH) reaches a mean maximum of 78% in the wet season with mean minimum range of 50 - 60% in dry months (Table 1). The lowest and highest RH recorded was 42% and 83% over the growing seasons. The mean wind speed (gust) varied between 7.6 – 10.4 km/h in Season I and 6.7 – 9.8 km/h in Season II (Table 1). The site had the history of cultivation with Napier grass intercropped with desmodium two years earlier followed by fallow with Kikuyu grass being the dominant vegetation. The rainfall data and the mean maximum and minimum temperatures obtained from the KARI-Naivasha Station for the experimental site were recorded for use in discussions.

3.2 Soil

KARI-Naivasha has clay loam soils of volcanic origin that are alkaline (pH=7.4), sodic and deep (NAHRC, 2003). Soil physical characteristics were determined using the Bouyoucos Method (1962 for textural classification at different soil profiles.

Table 1 Mean values of relative humidity, temperature (°C) and gust (km/h) at the experimental site (KARI-Naivasha) during chickpea growth

Mean of factor	Jan	Feb	Mar	Apr	May	Jun	Jul	Aug	Sep	Oct	Nov
Relative humidity (%)	59.4	58	64.2	76.7	72.3	74.3	71.0	70.1	63.1	62.0	78.4
Temperature (°C)	22.3	21.7	21.8	19.8	19.3	17.7	16.6	17.5	18.6	20.1	19.0
Gust (km/h)	18.4	10.5	18.8	8.7	14.4	6.8	15.8	8.5	9.1	10.1	6.9

3.3 Experimental Design and Layout

The experiment was laid out in a split-plot in randomized complete block design (Fig 1). The tillage method (T) formed the main plots while the sowing time (S) formed the subplots (Treatment Plots). First sowing (S1) begun with planting at onset of rains. An interval of seven days separated the sowing dates. The main plot and subplot treatments were randomly allocated to main plots and subplots respectively. Each treatment plot measured 4 x 3 m². A 2 m footpath was left between the subplots and 5m spacing between blocks to enable turning of the tractor (head turn). Treatments were allocated to the subplots, which were 1m apart. Each subplot had eight rows of ICCV chickpea having fifteen plants each at a spacing of 50 x 20 cm. This gave a population of 200, plants/ha. A total plot area of 1,200m² was used for the three blocks.

3.4 Weather Data Collection and Graphs

The KARI-Naivasha Station provided the following tabulated data from the weather station over two years (2004 – 2005 years): rainfall, wind speed, daily temperatures and dew point averages

3.5 Crop Establishment and Management

Seedbed preparation was carried out by use of a tractor (International 3220) on hire on 18th December 2004 before the onset of the rains for Season I and 19th – 23rd June 2005 after second harvesting of the first season crop, in readiness for planting. In conventional tillage (CT), a single disc ploughing was followed by a single harrowing while for strip

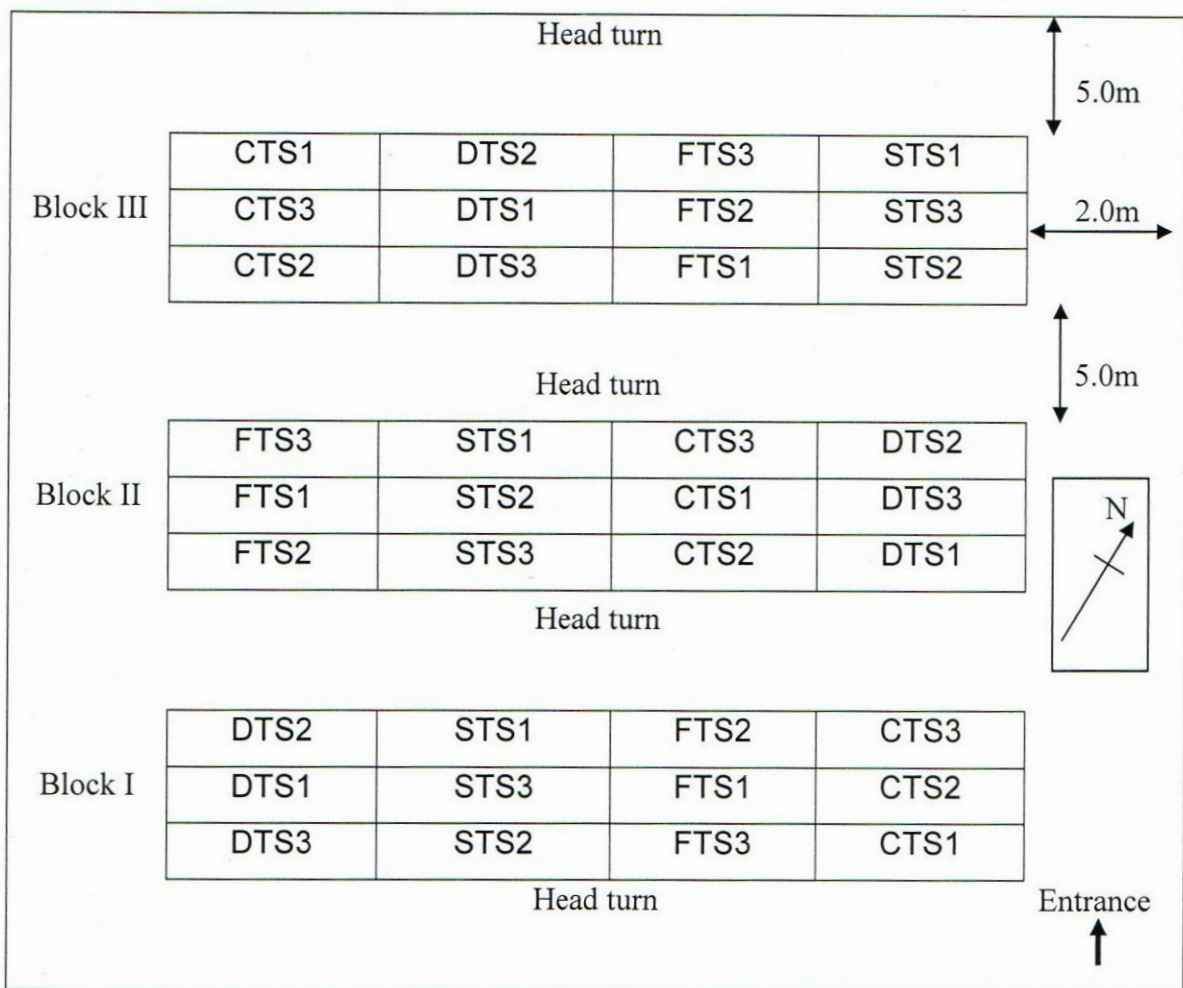

Figure 1 Layout plan of the experiment

Legend: CTS1 – First sowing time as a split in conventional tillage method

tillage (ST) a 20 cm strip of land was opened manually after a glyphosate herbicide had been sprayed of least a week before first planting to control weeds. Any conspicuously large weeds were slashed before applying the glyphosate. Double digging (DT) involved a primary and secondary manual hoeing along the rows where sowing was done. This was a modified form of double digging where the depth of hoeing is done manually to depths below 20 cm for the whole field. Furrow tillage (FT) involved making furrows across the treatment plot(s) using hand ridgers after primary and secondary hoeing. Seeds were sown along the furrows.

Table 2 Rainfall amount per growth phase of *kabuli* chickpea (days after sowing) under different sowing times at KARI-Naivasha in Seasons I and II

Season	Sowing dates	Rainfall (mm) per stage of chickpea growth (DAS)						Total (mm)
		0-35	35-63	63-91	91-119	119-133	133-161	
I	First sowing	53.4	16.9	50.7	47.5	46.5	72.0	286.0
	Second sowing	33.3	15.5	35.2	55.6	62.6	47.8	249.0
	Third sowing	33.3	15.5	74.9	54.3	24.2	47.8	250.0
II	First sowing	19.4	76.8	43.0	57.0	0.0	10.7	206.9
	Second sowing	10.2	71.8	37.5	57.0	10.7	5.2	191.4
	Third sowing	18.2	83.3	28.5	57.0	10.7	5.2	202.9

Legend: DAS = days after sowing

Table 3 Mechanical composition of the soil the experimental site at KARI-Naivasha

Soil profile depth (cm)	Particle composition (%)			Identified soil type
	Sand	Silt	Clay	
0 – 20	52	32	16	Sandy loam
20 – 40	58	28	14	Sandy loam
40 – 60	48	38	14	Loam
60 – 90	32	42	26	Clay loam
90 - 110	34	38	28	Clay loam

Table 4 Physical constants of the soil at the experimental site

Soil profile depth (cm)	Bulk density (g cm ⁻³)	Filed Capacity (mm)	Wilting Point (mm)	Available water content (mm)
0 – 20	1.30	93.6	73.4	20.2
20 – 40	1.36	114.2	80.3	33.2
40 – 60	1.32	116.2	75.7	40.5
60 – 90	1.24	193.4	100.1	93.3
90 – 110	1.25	130.0	67.8	62.2
Total (110 cm depth)		647.4	397.3	250.1
Equivalent Total (100 cm depth)		588.6	361.2	227.4

Two seeds of chickpea were sown per hole at a spacing of 50 cm between rows and 20 cm along the rows. They were later thinned to one plant per hill a week after emergence i.e. thinning about 14 days after sowing. Emergence of seedlings was scattered in the better half of the growing period. Seeds of kabuli type chickpea variety ICCV95423, compound fertilizer (17:17:17), fungicides and pesticides were used. At sowing time the compound fertilizer was applied at the rate of 150 kg N ha⁻¹. This was based on the recommendation that a starter dose of 15 – 25 kg N ha⁻¹ is necessary where chickpea is being grown for the first time to encourage nodulation and the upper limit was chosen for the purpose.

Manual weeding was first done four weeks after emergence in Season I and again at 84 DAS. In the second season the weeding was done only once at 77 DAS. A broad spectrum systematic pesticide, dimethoate (DANADIM 40 ©) was used to spray against field crop pests first at seven days after emergence then every two weeks afterwards or as need arose. A mixture of 40 cm³ Dimethoate40 © and 120g of fungicide (RIDOMIL ©) were dissolved in 20 litre of water in a knapsack sprayer giving a rate of 2 litres per hectare.

3.6 Data Collection

3.6.1 Plant sampling

All data was progressively taken every two weeks and unique occurrences noted whenever observed. Three plants were randomly selected in each treatment plot and used throughout the growing period to measure various representative parameters. The data collected from these plants were mean height (cm) above ground surface, mean number of primary and secondary branches as well as the mean number of leaves on primary and secondary branches.

3.6.2 Plant height

The plant height was measured in centimeters (cm) using a metre rule. Since ICCV95423 chickpea is semi-erect three height readings above the ground level and close to the stem were taken for each of the three representative plants taken at each time of measurement.

The mean height of the three plants was then later calculated and recorded for the treatment plot. Height readings were taken at 35, 63, 91 and 119 DAS. There was a change in time of taking first readings from 14 to 21 DAS and since many readings were taken only four indicated were used for the thesis writing. These were chosen since they approximated the times of first flower, 50% flowering, maximum LAI and time to physiological maturity as will be seen in later sections.

3.6.3 Flowering

Observation for flowering was started at 28 days after sowing (DAS) and the number of flowered plants recorded every week thereafter until when more than half of the sub-plot plants had flowered. Graphs of percent flowered plants against time of growth (DAS) were plotted to determine time for each sub-plot to attain 50% flowering.

3.6.4 Leaf Area Index

Leaf area index (LAI) was measured using a leaf area meter (Model LI-3000) by measuring the leaf area of at least three leaves of each of the representative plants at each time of measurement and calculating the mean area of a single leaf. Due to the small size of the chickpea leaves it was found necessary to draw the live leaves by tracing them and comparing the area recorded by the instrument. A conversion factor was thus more convenient than direct measurement as the crop grew in height and canopy cover (Eq. 1).

Leaf area conversion factor (F_c) = Area of traced leaf/Area of leaf by meter 1

The numbers of leaves per primary and secondary branch (L_p and L_s) as well as their corresponding number of branches (B_p and B_s) were used to determine the LAI thus:

$$LAI = F_c A_L (B_p L_p + B_s L_s) / (0.50 \times 0.20). \dots\dots\dots 2$$

Where F_c = area conversion factor; A_L = mean leaf area; B_p and B_s are the mean numbers of primary and secondary branches; L_p and L_s were the mean number of primary and secondary leaves at time of measurement. The $0.50 \times 0.20 \text{ m}^2$ defined the area of a representative plant on the ground.

3.6.5 Biomass and Grain Yield

Data on biomass was taken at 35 DAS, 63 DAS and at harvest. The first two intervals coincided with the approximate time for appearance of first flower and 50% flowering, respectively. Three plants were randomly selected and uprooted from within the treatment plots. These were then labeled accordingly, weighed immediately then taken for drying in an electric oven at 60°C to constant dry weight. The dry plants were then weighed using electronic weighing balance (Model: TANITA TLD-610). The weights were converted to kg/ha before being used for statistical analysis. At harvest the three plants used for growth parameter measurements were uprooted after counting the number of pods. The pods were then removed together with the grains and sun dried to constant mass before shelling to obtain the seeds, which were then dried, weighed and recorded. The difference between the total dry pod weight and the dry grains gave the weight of the pods. Out of these grains the 100-seed weight was determined for each sub-plot. Three plant samples from 0.03 m² were harvested and dried at 60°C overnight to constant dry weight. The number of plants ha⁻¹ and pods/plant were determined. The aboveground dry matter, in kg ha⁻¹, at harvest was calculated after the residue plant was oven dried to constant weight at 60°C (Eq. 3). In all biomass measurement cases only the above-ground-biomass was taken, as it was no possible to get underground mass in the soil.

Biomass at harvest = mass of residue plant + mass of pods + mass of grains 3

Water use efficiency was calculated for the grain and total biomass using Equation 4 and Equation 5:

$$WUE_g = \text{Grain yield (kg/ha)/ET(mm)} \dots\dots\dots 4$$

$$WUE_b = \text{Plant aboveground biomass (kg/ha)/ET(mm)} \dots\dots\dots 5$$

where WUE_g and WUE_b are the water use efficiency of the grain yield and the total dry biomass in kg/ha/mm, respectively and ET is the calculated evapotranspiration in mm over the growing period using the water balance equation (Eq. 14).

3.6.6 Volumetric water content measurement and installation of access tubes

Due to the dryness during the time of sowing, an initial post-sowing irrigation of 87.5mm was given for the purpose of inducing germination. This was considered to simulate rainfall. Moisture readings were taken at 21 days after sowing (DAS) in both seasons and thereafter at two-week intervals. Measurements of other parameters described above were synchronized accordingly in both seasons. A neutron probe, Model 4300, was used for soil moisture determination at different depths at two-weekly intervals after respective sowing dates. The depths that defined soil layers for moisture determination were 0-20, 20-30, 30-40, 40-60, 60-90 and 90-110cm. A standard count was always taken before taking readings at any one time by noting the rate while the probe is in the wax case enclosed in the shield of the neutron probe.

Installation of access tubes for neutron probe measurements was done before planting. Soil moisture content at 0 – 20, 20 – 40, 40 – 60, 60 – 90, and 90 – 110 cm soil profiles were measured by use of a neutron probe. Access tubes were installed in each subplot for use in soil moisture determination starting with first sowing time (S1). A soil auger was used to drill the holes for placement of the access tubes. The PVC tubes used were Class A commercial pipes of 2-inch internal diameter which were cut to 170 cm lengths. The lower end was sealed then carefully lowered into the bored holes so that a length of 60 cm was left exposed above the ground surface. The exposed end of the access tubes provided entry for the neutron probe to be lowered when taking equivalent moisture readings in the soil as counts of thermalised hydrogen atoms per minute. The tubes were also covered with plastic lids to prevent entry of water due to precipitation. Soil moisture was related to the neutron probe counts by a series of conversions that involved the standardizing of the neutron probe using soil core rings for bulk density determination and count rates in the soil. The count rate ratio (simply referred to count ratio and denoted by N) was related to the standard count of the neutron probe thus:

$$\text{Count ratio (N)} = \text{Counts in soil/Standard count. 6}$$

Greacen (1981) and IAEA-Vienna (2002) describe the relationship between count ratio

and volumetric water content (Θ) thus:

$$\Theta = mN + c \dots\dots\dots 7$$

where m is the slope and c the intercept of the regression function representing volumetric water content (Θ) as a function of N , the count ratio. The gravimetric water content (w) was determined as follows:

$$w = (\text{wet mass of soil} - \text{dry mass of soil}) / \text{dry mass of soil} \dots\dots\dots 8$$

The soil bulk density (ρ_b) and volumetric soil water content for each soil layer was calculated thus:

$$\rho_b = \text{dry mass of soil} / \text{bulk volume of soil} = m_s / v_s \dots\dots\dots 9$$

and

$$\Theta = w \times \rho_b / \rho_w, \dots\dots\dots 10$$

where ρ_w is the density of water (1 g cm^{-3}). A standard calibration curve was drawn and used to estimate soil moisture at different depths.

Since the depth moisture gauge used is not meant to measure soil moisture of surface layers, two different calibrations were done: one for the 0-20 cm (Eq. 11) and the other for the 20-110 cm depth layers (Eq. 12), the units being m^3/m^3 .

$$\Theta_v = 4N + 0.258 \dots\dots\dots 11$$

$$\Theta_v = 0.214N + 0.341 \dots\dots\dots 12$$

3.6.7 Evapotranspiration

The evapotranspiration was determined by use of the water balance equation as described and derived from FAO (1998) and Shelton et al. (2002):

$$(P + I) - (R + D + E + T) = \Delta S \dots\dots\dots 13$$

$$(\text{Gains}) - (\text{Losses}) = (\text{Change in storage})$$

in which P=precipitation, I=irrigation, R=runoff from the field, D=downward drainage out of the root zone, E=evaporation from the soil, T=transpiration from the plant canopy, ΔS =change in soil water content of the root zone.

Since $ET = E + T$, slope <2% and no deep drainage was noted then Equation 14 reduces to:

$$ET = P + I + \Delta S - R \dots\dots\dots 14$$

ET was determined using this water balance equation above.

3.6.8 Field Capacity and Bulk Density

To determine the field capacity (FC) of the soil, an area 1x 1m² was randomly taken in the experimental field between the blocks and two access PVC and aluminum tubes installed there. This area was to form internal dimensions of a 'dam' made by scraping soil from the outside to form wall heaps to enclose added water. For clay soil about 600 litres of water was required to saturate 1m³ of dry soil. The dam was filled with enough water to saturate the soil profile completely (Michael, 1997). After saturation the dam was covered with plastic sheeting to prevent any evaporation losses from the soil surface and then allowed to drain for 48 hours before measurements were taken to determine FC. A pit was dug to enable taking of soil samples at different depths as neutron probe readings were concurrently taken for the same at corresponding depth. These values were then used to calibrate the instrument. At these corresponding depths two soil core samplers were used to collect soil for bulk density determination. The mass of the wet soil and core ring with a lid were oven drying at 105⁰C to constant mass then weighed using an electronic weighing balance. The cores dimensions were measured and used to find the volume of the core sampler. These volumes and the dry masses of the soil in them were used to calculate the mean bulk density of the soil at the depth in question for use in Equation 10.

3.6.9 Infiltration Rate

The soil moisture levels before and after the irrigation in Seasons I and II were measured to estimate the level of infiltration by applying the principle of change in soil water storage before and after rainstorms using a neutron probe (Gaze *et al.*, 1997). The time of applying the rescue irrigation water was used as the time of the 'rainstorm'. The



differences in soil moisture levels were determined after 48 hours using Equations 13 and 14 to give the measure of infiltration rates in Season I (January 2005) and Season II (June-November 2005). The results were subjected to analysis of variance (ANOVA) using the GLM of SAS computer package as was the case with other measured variables.

3.4.10 Weather Parameters

Daily weather parameters were recorded from the Agro-Meteorological Station at KARI-Naivasha center. These included seasonal rainfall, wind speed, daily maximum and minimum temperature and percent relative humidity (Table 2).

3.5 Analysis of Data

Data collected was subjected to analysis of variance (ANOVA) using the GLM of SAS computer package (1997). Regression and correlation analyses were carried out where necessary. The model for yield of chickpea that was used in the DM-ET regression analysis was:

$$Y_{ijk} = \bar{u} + \alpha_i + \beta_j + \beta_{ij} + \gamma_k + (\beta\gamma)_{jk} + \varepsilon_{ijk}, \dots\dots\dots 12$$

(i=1,2,3; j=1,2,3,4 and k=1,2,3)

where Y_{ijk} = Total yield per treatment; \bar{u} = overall mean; α_i = i^{th} blocking effect on yield; β_j = j^{th} tillage method effect on yield; β_{ij} = tillage method error [Error (a)]; γ_k = k^{th} sowing time effect on yield; $(\beta\gamma)_{jk}$ = interactive effect of the j^{th} tillage method and the k^{th} sowing time on yield; ε_{ijk} = sowing time error.

The means were separated using least significant difference (lsd) for study factors while the Duncan's multiple range test (DMRT) was used where interactions were observed.

CHAPTER FOUR

4.0 RESULTS

4.1 Growth attributes

4.1.1 Plant height

4.1.1.1 Effect of tillage method on plant height

Under all tillage methods, plant height was observed to increase with time (Table 5). It ranged from 12.9 - 15.4 cm at 35 days after sowing (DAS) and 39.7 - 45.1 cm at 119 DAS in Season I (January-June) period. In the June-November (Season II) period the height ranged between 12.3 - 12.5 cm and 42.8 - 47.7 cm at 35 and 119 DAS, respectively.

Tillage method effects on plant height (Table 5) showed that strip tillage (ST) resulted into taller plants of 45.1 and 47.8 cm compared to the other tillage treatments by 119 DAS in Season I ($P < 0.05$). In Season II, however, the tillage effects were not significant throughout the growing period at the same level of significance. The maximum mean height by 119 DAS ranged from 39.7 to 45.1 cm and 42.8 to 47.7 cm in Season I and II, respectively.

4.1.1.2 Effects of sowing time on plant height

The height of chickpea increased successively under all sowing treatments from between 13.1 - 15.1 cm range at 35 DAS to a maximum of 41.5 - 46.4 cm range at 119 DAS in both seasons (Table 5). In Season I the tallest plants were observed under the third sowing time (S3) at all stages of chickpea growth ($P < 0.05$). For the Season II crop, however, S3 heights were shorter at the 35 and 63 DAS, but taller by 91 and 119 DAS periods. The maximum height by 119 DAS was 43.8 under S3 in Season I and 46.4 cm under S1 in Season II. In the second season (Table 5) however, S3 had the shortest plants (11.0 and 26.3 cm) at 35 and 63 DAS, respectively. Chickpea heights were 12.5 and 13.5 cm at 35 DAS and 30.0 and 30.7 cm at 63 DAS, respectively under S1 and S2 treatments, respectively. At 91 DAS and 119 DAS, all sowing date treatment effects on height of chickpea were statistically similar ($P < 0.05$).

Table 5 Effects of tillage method and sowing time on plant height (cm) of *kabuli* chickpea at different times of growth at KARI-Naivasha in Seasons I and II

Treatment	Season I (30 th Dec 2004-22 May 2005)				Season II (21 st Jun -15 th Nov 2005)			
	35	63	91	119	35	63	91	119
Conventional tillage	12.9c	32.0b	37.2c	39.7c	12.3a	28.1a	40.8a	42.8a
Double digging	14.4b	32.7a	39.6b	43.0b	12.3a	30.3a	42.5a	44.4a
Furrow tillage	13.9b	30.6a	39.7b	43.8b	12.1a	27.9a	41.8a	43.9a
Strip tillage	15.4a	32.8a	41.6a	45.1a	12.5a	29.6a	45.6a	47.7a
Lsd	0.60	1.21	1.41	0.96	1.50	3.00	7.06	6.93
First sowing	14.3b	32.4a	39.6a	42.8b	12.5a	30.0a	44.2a	46.4a
Second sowing	13.1c	30.5b	38.3b	42.2ab	13.5a	30.7a	44.4a	46.1a
Third sowing	15.1a	33.1a	40.6a	43.8a	11.0b	26.3b	39.5a	41.5a
Lsd	0.52	1.05	1.22	0.83	1.34	2.60	6.12	6.00
Coefficient of variation	4.24	3.79	3.58	0.93	12.55	10.36	15.66	15.51
Mean	14.2	32.0	39.5	42.9	12.3	29.0	42.7	44.7

Means within a column followed by the same letter(s) are not significantly different from each other at 0.05 level of probability

Legend: lsd = least significant difference

Tillage method and sowing time interactive effects on height of chickpea showed no significant differences at all respective stages of growth in both seasons.

4.1.2 Leaf Area Index

4.1.2.1 Effects of tillage methods on leaf area index

Irrespective of tillage treatments, the leaf area index (LAI) of the *kabuli* chickpea was observed to increase with maturity up to 91 DAS in both seasons after which it declined by 119 DAS (Table 6). LAI ranged from 0.19 - 0.25 and 0.20 - 0.22 at 35 DAS and 2.50-3.31 and 4.2-5.4 at 91 DAS in Season I and Season II, respectively. By 119 DAS, LAI declined and ranged between 1.97 - 2.13 $m\ m^{-1}$ in Season I and 1.02 - 1.20 cm in Season II DAS. Conventional tillage method (CT) resulted in lower LAI (2.50) by the 91 DAS in Season I. It declined to 1.68 by the 119 DAS but it was however significantly similar to the double tillage (DT) and furrow tillage (FT) practices at this time of growth. In Season II, LAI differed significantly only at 91 DAS when maximum values were recorded (Table 6). The highest LAI of 5.44 under strip (ST) and 4.71 under both DT and FT tillage practices were observed, respectively. The latter two were however statistically similar with CT tillage method which had a LAI of 4.22. Seasonal comparison showed that under all tillage treatments the LAI was comparatively greater for season II than for the Season I chickpea crop by 91 DAS. Strip tillage method had relatively the greatest LAI (5.44 in Season II and 3.31 in Season I) while conventional tillage method had the lowest LAI (2.50 in Season I and 4.22 in Season II).

4.1.2.2 Effects of sowing time on leaf area index

LAI increased with growth under all sowing times for both seasons until 91 DAS before declining to a minimum by harvest time (Table 6). Further growth beyond 91 DAS revealed a decline in the LAI by the 119 for both seasons. The results also revealed that S3 gave the highest value of LAI at all stages of growth compared to the other sowing treatments in Season I. In Season II, however, S3 resulted in the lowest LAI values of chickpea at 35 DAS and 91 DAS in comparison to the other sowing dates, which were at

Table 6 Effects of tillage methods and sowing times on the leaf area index ($\text{m}^2 \text{m}^{-2}$) of *kabuli* chickpeas grown at KARI-Naivasha in Seasons I and II

Treatments	Season I				Season II			
	35	63	91	119	35	63	91	119
Conventional tillage	0.19b	1.39a	2.50b	1.68b	0.20a	1.34a	4.22b	1.02a
Double digging	0.19b	1.66a	3.16a	1.97ab	0.21a	1.43a	4.71ab	1.04a
Furrow tillage	0.19b	1.68a	3.23a	1.90ab	0.21a	1.34a	4.71ab	1.03a
Strip tillage	0.25a	1.70a	3.31a	2.13a	0.22a	1.55a	5.44a	1.20a
lsd	0.036	0.245	0.326	0.325	0.054	0.578	0.88	0.399
First sowing	0.20b	1.63a	3.10a	1.90ab	0.23a	1.47a	5.02a	1.34a
Second sowing	0.17c	1.42b	2.80b	1.74b	0.23a	1.61a	5.69a	1.19a
Third sowing)	0.24a	1.77a	3.20a	2.12a	0.17b	1.17a	3.59a	0.98
lsd	0.031	0.212	0.282	0.281	0.047	0.5	0.762	0.435
Coefficient of variation	17.71	15.23	10.7	16.93	25.58	40.78	18.47	37.26
Overall mean	0.20	1.61	3.03	1.92	0.21	1.42	4.77	1.07

Means within a column followed by the same letter are not significantly different from each other at 0.05 level of probability

Legend: lsd = least significant difference

par with each other. In this Season II, sowing time had no significant effects ($P < 0.05$) on LAI at 63 and 119 DAS. LAI ranged from 0.17 - 0.25 and 0.17 - 0.23 at 35 DAS to a maximum of 2.80 - 3.20 and 3.59-5.69 by 91 DAS in Season I and Season II, respectively. There were no interactive effects of tillage method and sowing date on LAI of *kabuli* chickpea in both seasons. The sowing time effects revealed that Season II had relatively greater LAI compared to the Season I *kabuli* chickpea crop. By 91 DAS when LAI was at the maximum, the second sowing time (S2) in Season II had a LAI of 5.69 compared to the third sowing time (S3) in Season I which had a LAI of 3.20.

4.1.3 Total above-ground biomass

4.1.3.1 Effects of tillage method on dry matter yield

The results of revealed that the chickpea plant total aboveground biomass accumulated progressively over the growing period under all tillage (Table 7). The biomass ranged from 78.7 - 100.4 kg DM/ha by 35 DAS and 3,242.1 - 4,231.3 kg DM/ha at harvest in Season I, respectively. The biomass in Season II ranged from 67.9 - 69.8 kg DM/ha by 35 DAS and 3,035.8 - 4,556.1 kg DM/ha at harvest (133 DAS), respectively. Plant biomass was relatively higher in Season I compared to Season II up to the time of pod setting (about 77 DAS). Over this growth period, conventional tillage (CT) resulted in consistently lower biomass accumulation ($P < 0.05$) even though it was at par with DT and FT at 35 DAS. On the other hand, strip tillage (ST) gave the greatest biomass accumulation ($P < 0.05$) throughout the growing period of chickpea.

In Season II, plant biomass was statistically similar by 35 DAS and by 63 DAS but showed significant differences ($P < 0.05$) by 77 DAS and by 133 DAS under all tillage treatments (Table 7). At these later stages of growth in the second season, strip tillage (ST) method resulted in the highest plant biomass production compared to the other tillage methods; it was however statistically similar with DT at 35 DAS whereas DT, FT and CT produced statistically similar biomass throughout the growing period. A comparison of seasonal production of total dry aboveground biomass by chickpea revealed that the Season I crop produced relatively higher than Season II crop at harvest time under all tillage methods except for strip tillage (Fig 2).

Table 7 Effects of tillage method and sowing time on total aboveground dry matter biomass of *kabuli* chickpea at different times of growth at KARI-Naivasha in Season I and II

Treatment	Time in days after sowing							
	Season I				Season II			
	35	63	77	133	35	63	77	133
Conventional tillage	78.7b	621.4b	1490.7b	3242.1b	67.9a	577.6a	1353.4b	3208.9b
Double digging	89.9ab	902.1a	2149.2ab	3994.9ab	69.4a	634.2a	1571.3b	3073.0b
Furrow tillage	88.9ab	886.4a	2127.1ab	4229.0ab	68.3a	587.8a	1317.7ab	3035.8b
Strip tillage	100.4a	966.3a	2288.9a	4231.3a	69.8a	671.2a	1837.9a	4556.1a
lsd	12.09	240.56	620.43	715.10	8.15	228.63	304.58	1304.10
First sowing	98.3a	897.8a	2145.6a	3893.0a	71.8a	659.0a	1901.6a	4263.2a
Second sowing	89.0a	853.3a	2012.3a	3784.3a	70.2ab	761.9a	1838.5a	3204.1ab
Third sowing	89.6a	781.2a	1884.1a	4095.8a	64.5b	432.4b	1220.2b	2938.1b
lsd	10.65	208.33	537.31	619.30	7.06	198.00	263.77	1129.1
Overall mean	89.5	844.1	2014	3924.3	68.8	617.8	1653.1	3468.4
Coefficient of variation	13.52	28.52	30.83	18.23	11.85	37.03	20.05	37.62

Means within the same column followed by the same letter are not significantly different at 0.05 level of probability

Legend: lsd = least significant difference; NS = not significantly different

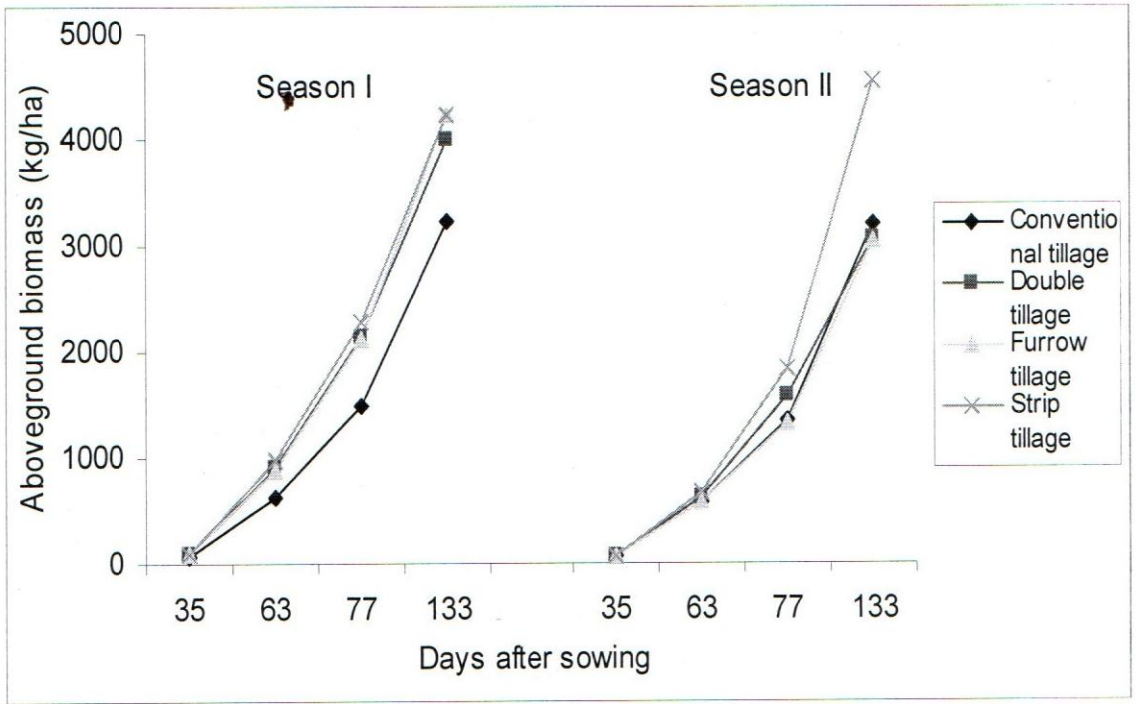

Figure 2 Effects of tillage methods on aboveground dry matter biomass of chickpea grown at KARI-Naivasha in Season I and II

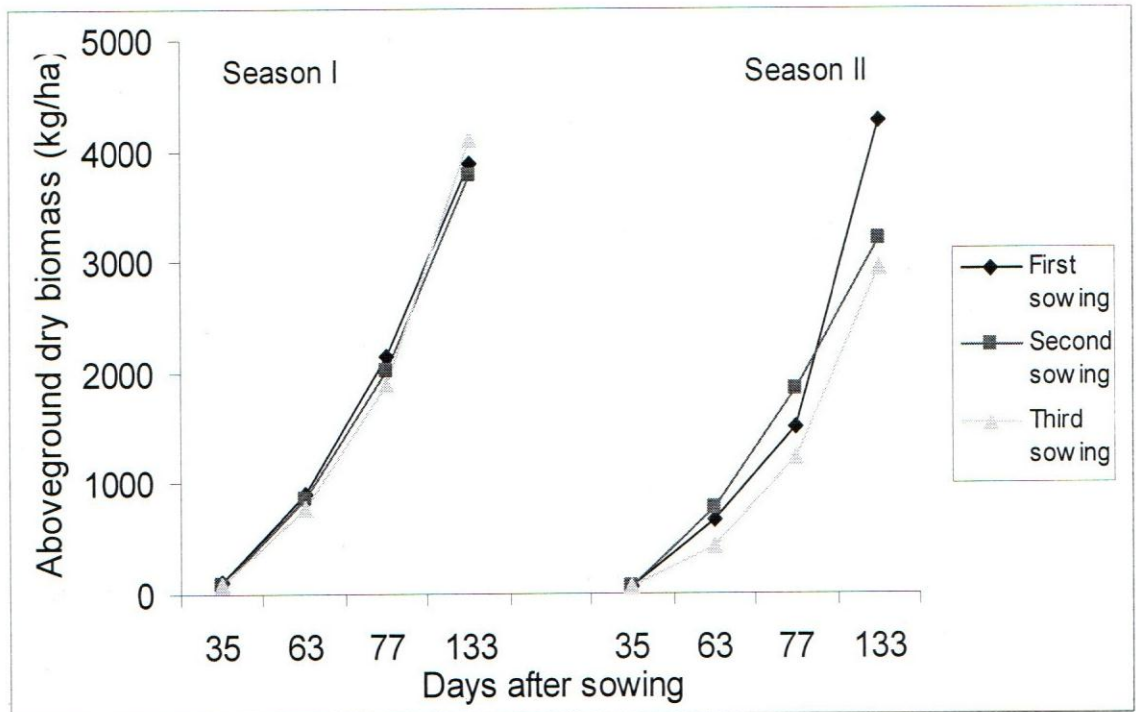

Figure 3 Effects of sowing times on aboveground dry matter biomass of chickpea grown at KARI-Naivasha in Season I and II

4.1.3.2 Effects of sowing time on plant biomass

Chickpeas total aboveground biomass production increased progressively with maturity under all sowing time treatments (Table 7 and Fig 3). The total aboveground biomass produced ranged from a minimum of 89.0 - 93.8 and 64.5 - 71.8 kg DM/ha at 35 DAS, to a maximum of 3,784.3 - 4,095.8 and 2,938.1 - 4,263.2 kg DM/ha at harvest (133 DAS) in Season I and II, respectively. Effects of sowing dates on the plant biomass production were not significant ($P < 0.05$) in Season I, but resulted in significant differences in Season II (Table 3). In Season II, third sowing (S3) caused the lowest dry biomass production throughout the period of growth. It was however at par with second sowing (S2) which was also at par with first sowing date (S1) in this second season. There were no interactive effects of tillage and sowing time observed for the biomass production throughout the period of chickpea growth in both seasons (Table 7). Biomass production by chickpea at harvest time showed that late sown chickpea (S2 and S3) produced more aboveground biomass in Season I than in Season II. In the first sowing time, however, the chickpea in Season II (June – November 2005) produced more biomass than that of season I by harvest time (Fig 3).

4.1.4 Flowering and Maturity

4.1.4.1 Time to flowering

4.1.4.1.1 Effects of tillage method on flowering time

The mean time to first flower for the *kabuli* chickpea showed no significant differences in Season I under the tillage methods with ST and FT methods taking the longest time in this season compared to the other tillage methods, which were statistically similar with each other (Table 8). The time to first flower ranged between 32.7 - 35.0 DAS in this season. In Season II, all tillage methods resulted in similar mean time to first flower that ranged between 33.4 - 37.3 DAS under all tillage treatments (Table 8). Tillage method treatment effects were similar on the time required by the chickpea to attain 50% flowering in both seasons. The period ranged from 60.3 - 64.1 DAS and 59.6 - 63.3 DAS in Season I and Season II, respectively. The corresponding overall mean times for Season I and Season II were 61.8 and 61.4 DAS, respectively.

Table 8 Effects of tillage method and sowing time on maturity times (days after sowing) of the *kabuli* chickpea grown at Naivasha in Seasons I and II

	<u>First flower</u>		<u>50% flowering</u>		<u>Physiological maturity</u>		<u>Time to ratoon maturity</u>
	Season I	Season II	Season I	Season II	Season I	Season II	Season I
Conventional tillage	35.0a	35.8a	61.8a	61.2a	120.6a	119.8a	146.2a
Double digging	29.6a	33.4a	60.3a	59.6a	119.0a	121.3a	147.0a
Furrow tillage	32.7a	37.3a	64.1a	63.3a	122.1a	121.3a	147.0a
Strip tillage	32.7a	36.6a	60.9a	61.4a	119.0a	119.8a	143.1a
lsd	3.40	4.95	7.37	9.00	5.59	2.69	7.99
First sowing	31.5a	33.8a	57.5a	56.9a	120.8a	121.9a	147.0a
Second sowing	32.1a	36.7a	63.1a	62.7a	119.6a	120.8a	147.6a
Third sowing	33.8a	36.7a	64.8a	64.8a	120.2a	119.0a	142.9a
lsd	2.94	4.28	6.37	7.80	6.92	2.26	6.92
Coefficient of variation	10.47	13.83	11.93	14.67	4.66	2.16	5.48
Means	32.5	35.8	61.8	61.4	120.2	120.6	145.8

Means in the same column followed by the same letter are not significantly different from each other at 0.05 level of probability

Legend: lsd=least significant difference; NS = not statistically significant

4.1.4.1.2 Effects of sowing time on flowering time

It was observed that sowing dates had no significant effects on both the time to first flower and the time to attain 50% flowering of chickpea in both seasons (Table 8). The mean time ranged from 31.5 - 33.8 DAS and 33.8 - 36.8 DAS to first flower and 57.5-64.8 and 56.9 - 64.8 DAS to reach 50% flowering for sowing treatments in Seasons I and II, respectively. There were no interactive effects of tillage method and sowing time on the mean time to first flower or 50% flowering (Table 8).

4.1.4.2 Physiological Maturity

4.1.4.2.1 Effects of tillage method on physiological maturity

There were two physiological maturity indicators (time to attain 50% mature pods that had turned yellow and dry) in Season I and only one in Season II (Table 8). The results further indicate that this time ranged from 119.0 - 122.1 DAS and 119.8 - 121.3 DAS in Season I and Season II, respectively. In Season I, the ratoon crop physiological maturity dates ranged from 146.2 to 147.0 DAS. The two growth patterns of the two seasons were different because Season I received rains towards its end (early onset of rains for Season II) that changed the growing mode of the chickpea crop. Tillage method treatments had similar effects on the time required for the kabuli chickpea to reach physiological maturity of the main crop in both seasons as well as for the ratoon crop on Season I (Table 8). Therefore, irrespective of the growth pattern of the same chickpea cultivar, physiological maturity dates are independent of the four tillage methods for a given ecological zone.

4.1.4.2.2 Effect of sowing time on physiological maturity

It was observed that tillage method treatments resulted in similar effects on the time taken by the chickpea to attain physiological maturities in Season I (Table 8). The periods ranged from 119.6 - 120.8 and 142.9 - 147.6 DAS for the main and ratoon crops respectively. In Season II, the results reveal S1 took the longest time compared to the other sowing dates, which matured similarly. However, sowings S1 and S2 had similar time to attaining the main crop physiological maturity. Season II did not have a ratoon crop.

4.1.4.2.3 Interactive effects of tillage and sowing time on physiological maturity

In Season II, the interactive effects of the factors under study on physiological maturity were noted and were significantly different for the main crop by 119 DAS. Other than for the interaction effects associated with the CT method, all the other interactive combinations caused an early physiological maturity with late planting of chickpeas in Season II (Table 9). The time ranged from 114.3 (ST x S3) to 126.0 (DT x S1 and FT x S1) DAS, implying that late sown chickpea accelerates its time to physiological maturity compared to an earlier sown crop.

It was observed that FT x S1 and DT x S1 resulted in the longest time (126.0 DAS) for the chickpea to attain physiological maturity (50% dry pods) in Season II compared to FT x S3, ST x S2 and ST x S2 interactive effects which were, however, at par with each other. The rest of the interaction combinations between tillage method and sowing time had similar effects on the crop physiological maturity (Table 9).

Table 9 Tillage method and sowing interactive effects on the time (days after sowing) for *kabuli* chickpea to reach physiological maturity in Season II

Tillage method	Sowing time		
	First sowing	Second sowing	Third sowing
Conventional tillage	119.0b	121.3ab	121.3ab
Double digging	126.0a	123.7a	123.7a
Furrow tillage	126.0a	119.0ab	116.7bc
Strip tillage	119.0b	116.7b	114.3c
DMRT	5.12	5.12	5.12
Coefficient of variation (CV)	2.16	2.16	2.16
Mean (Overall)	122.9	120.2	119.0

Means within a column followed by the same letter(s) are not significantly different from each other at 0.05 level of probability according to DMRT

Legend: DMRT=Duncan's Multiple Range Test

4.2 Yield Attributes and Grain Yield

4.2.1 Number of Branches / Plant

4.2.1.1 Effects of tillage method on cumulative branches

Cumulative branches herein refer to the sum of the primary and secondary branches/plant of chickpea taken simultaneously at the time of data collection. The results indicated that the number of cumulative branches/plant successively increased with maturity under all tillage treatments (Table 10). They ranged between 19.4 - 31.0 and 9.9 - 13.2 at 35 DAS to 39.1 - 57.9 and 53.1 - 68.7 branches per plant at the 119 DAS, respectively.

The cumulative number of branches/plant differed significantly among the various tillage methods in both seasons except at 63 DAS in Season II (Table 10). In both seasons in ST the highest number of cumulative branches/plant throughout the growing stages was recorded. However, at 63 DAS in Season II the number of cumulative branches/plant were statistically similar with each other and ranged from 28.8 to 33.2 for CT and ST methods, respectively.

4.2.1.2 Effects of sowing time on cumulative branches

The numbers of cumulative branches per plant were observed to increase over the growing period under all sowing time treatments in both seasons (Table 10). They ranged between 23.4 - 26.0 at 35 DAS and 44.4 - 49.8 at 119 DAS branches/plant in Season I and Season II, respectively.

At 91 DAS, sowing date effects on cumulative branches/plant were found to be significantly ($P < 0.05$) different in Season I with the first sowing (S1) resulting in the highest number of 43.1 while S2 the lowest number of 37.3 cumulative branches per plant. However, total branches per plant of chickpea were similar at all the other stages of growth in Season I (Table 10). The interactive effects of tillage method and sowing time on cumulative number of branches/plant for chickpeas were not significantly different in both seasons.

Table 10 Effects of tillage method and sowing time on mean cumulative numbers of branches per plant of *kabuli* chickpea grown at KARI-Naivasha in Season I and II

Treatments	Time in days after sowing							
	Season I				Season II			
	35	63	91	119	35	63	91	119
Conventional tillage	25.7ab	35.7ab	41.7b	48.2b	9.9b	28.8a	37.4b	58.4ab
Double digging	24.2bc	32.0bc	39.0b	45.7ab	10.8b	31.1a	42.0ab	53.1b
Furrow tillage	19.4c	27.6c	32.1c	39.1c	11.0ab	31.1a	44.2ab	59.9ab
Strip tillage	31.0a	40.4a	51.6a	57.9a	13.2a	33.2a	51.4a	68.8a
lsd	6.21	7	7.38	7.2	2.32	6.96	10.69	14.19
First sowing	26.0a	35.8a	43.1a	47.1a	11.9a	31.8a	42.3a	60.1a
Second sowing	23.4a	34.7a	37.3b	44.9a	12.9a	36.1a	47.2a	64.4a
Third sowing	25.8a	31.3a	42.9ab	51.2a	8.3b	25.3b	41.7a	55.7a
lsd	5.37	6.06	6.39	6.24	2.01	6.03	7.31	NS
Coefficient of variation	24.75	20.66	17.96	15.1	20.66	22.42	19.93	23.64
Overall mean	25.1	33.9	41.1	47.7	11.2	31.1	43.8	60.1

Means in the same column followed by the same letter(s) are not significantly different from each other at 0.05 level of probability

Legend: lsd=least significant difference

The slope relating chickpea height number of branches/plant and LAI with maturity of chickpea under both tillage and sowing time treatments after the 63 DAS indicated an increase over time of growth in Season I. Similar trends were observed in Season II. Leaf expansion (LAI) appears to have influenced photosynthesis and hence DM production (Table 7) and ultimately grain yields (Table 11) obtained by 133 DAS in both seasons.

4.2.2 Number of pods per plant

4.2.2.1 Effects of tillage on number of pods

The number of pods/plant increased from podding (77 DAS) to harvest (133 DAS) time under all tillage methods except for DT at 77 DAS (Table 11). It ranged from 55.7 - 94.9 and 64.8 - 91.9 at 77 DAS to 61.2 - 104.6 and 131.1 - 168.3 pods/plant at 133 DAS. The mean number of pods/plant in Season I was lower compared to that in Season II at similar times of recording (Table 11).

Tillage method effects on the number of pods/plant differed significantly at the podding time in both seasons and at harvest only in Season I (Table 11). The results depict that ST resulted in consistently higher number of pods/plant at pod setting in both seasons and CT the lowest values than the other tillage methods. CT was however at par with FT in Season I and both DT and FT in Season II. At the time of harvest, tillage treatment effects on the number of pods/plant significantly differed only in Season I. Here, ST produced the greatest number of pods/plant compared to the other tillage method treatments which were however at par with each other. In Season II at harvest, tillage treatment effects produced a similar number of pods/plant.

4.2.1.2 Effects of sowing time on number of pods/plant

The number of pods/plant generally increased from podding to harvest under all sowing time treatments in both seasons (Table 11). They ranged 67.3 - 73.5 and 58.0 - 96.1 at 77 DAS to 72.8 - 79.3 and 104.1 - 180.0 at 133 DAS in Season I and Season II respectively.

Table 11 Effects of tillage method and sowing time on the number of pods/plant, 100-grain weight and grain yield of *kabuli* chickpea grown KARI-Naivasha in Seasons I and II

Treatment	Number of pods/plant				100-Grain weight (g)		Yield at 133 DAS (Kg ha ⁻¹)		Yield at 161 DAS	
	Season I		Season II						Total Grain (Kg ha ⁻¹)	% Grain increment
	Podding (77 DAS)	Harvest (133 DAS)	Podding (77 DAS)	Harvest (133 DAS)	Season I	Season II	Season I	Season II	Season I	Season I
Conventional tillage	55.7c	61.2b	64.8b	131.1a	39.8a	36.7a	1430.6a	1489.0b	1805.4b	26.2
Double digging	71.1b	69.7b	85.4ab	152.9a	39.4a	38.2a	1628.1a	1849.9b	2071.2ab	27.2
Furrow tillage	57.3c	70.4b	73.6ab	150.7a	40.3a	38.6a	1559.6a	1700.0b	2022.2ab	29.7
Strip tillage	94.9.a	104.9a	91.9a	168.3a	37.7b	39.2a	1798.2a	2544.9a	2334.7a	29.8
lsd	8.35	17.51	17.64	40.80	1.32	2.88	364.8	462.9	496.9	.
First sowing	67.3a	72.8a	96.1a	180.0a	40.2a	37.8a	1607.6a	2235.3a	2033.2a	26.5
Second sowing	68.3a	77.6a	82.7a	168.0a	39.0ab	37.5a	1573.8a	1902.9ab	1939.9a	23.3
Third sowing	73.4a	79.3a	58.0b	104.1b	38.7b	39.2a	1631.0a	1549.8b	2202.1a	35.0
lsd	7.23	15.17	15.28	35.33	1.14	1.93	300.4	400.9	421.68	.
Coefficient of variation	11.98	22.89	22.37	27.08	3.37	4.94	21.64	24.4	23.67	.
Overall mean	69.8	76.6	78.9	150.7	39.1	38.2	1604.1	1896.0	2058.4	28.3

Means in the same column followed by the same letter(s) are not significantly different from each other at 0.05 level of probability

Legend: lsd=least significant difference; DAS=days after sowing

The time of sowing resulted in a similar number of pods/plant in both seasons at podding and at harvest in Season II (Table 11). The third sowing (S3) produced the lowest number of pods/plant compared to the first (S1) and second (S2) sowing dates which were however statistically similar. Interactive effects of tillage method and sowing time on *kabuli chickpea*'s number of pods/plant were non-significant at podding or harvest in both seasons.

4.2.3 Grain yield of chickpea

4.2.3.1 Effects of tillage method on grain yield

It was depicted that the grain yield of the *kabuli* chickpea was higher in Season II compared to Season I under all tillage practices at harvest time, 133 DAS. However, Season I had two harvests whose overall grain yield was greater than that of Season II under all tillage methods except for ST method in Season II which nevertheless resulted in greater grain yield in the single harvest. These observations indicate that of the chickpea plant of ICCV95423 has an indeterminate growth pattern and that continued reproductive growth depends on the availability of soil moisture. Thus continuous moisture availability can boost the overall grain yield where irrigation water is available, an ideal case for farmers in the marginal areas of Kenya. The grain yields ranged between 1,430.6 - 1,798.2 and 1,489.0 - 2,544.9 kg/ha at harvest in Season I, and II, respectively. The overall grain yield for Season I ranged between 1,805.4 - 2,334.7 kg/ha among tillage methods (Table 11).

The first and second grain yield harvests of chickpea were statistically similar in Season I under all tillage methods (Table 11 and Fig 4). However, in Season II, grain yield at 133 DAS differed significantly between tillage methods with the ST method resulting in superior grain yield compared to the other tillage methods that were at par with each other. In this second season (June-November, 2005), only one harvest at 133 DAS was possible compared to two in Season I at 133 and 161 DAS due to rains received after 63 DAS. There were no significant tillage method and sowing time interaction effects on grain yield observed in both seasons and harvest dates.

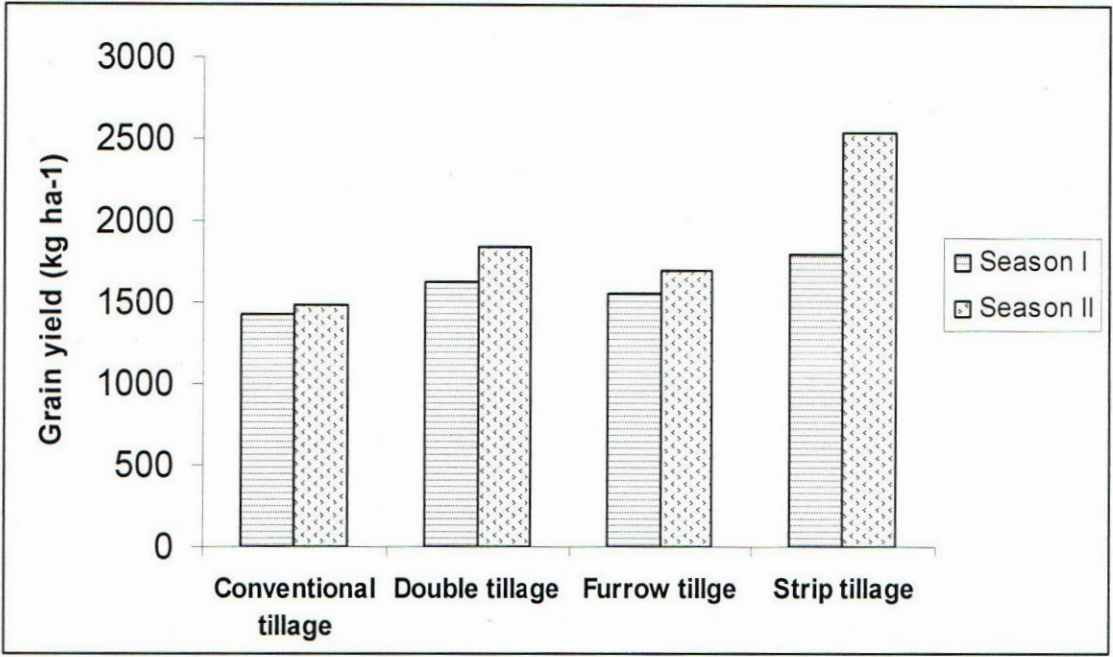

Figure 4 Effects of tillage methods on grain yields (133 DAS) *kabuli* chickpea grown at KARI-Naivasha in Seasons I and II

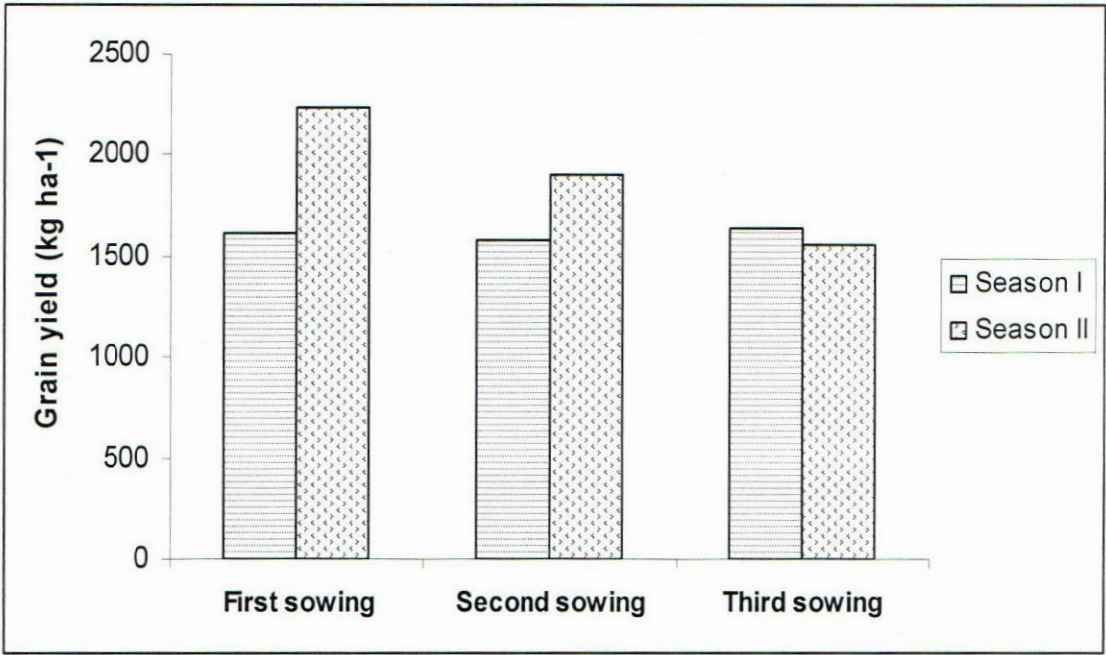

Figure 5 Effects of sowing times on grain yields (133 DAS) *kabuli* chickpea grown at Naivasha in Seasons I and II

4.2.3.2 Effects of sowing time on grain yield

Table 11 indicate that Season I realized two harvests, i.e. 133 and 161 DAS, compared to Season II due to the crop's indeterminate growth habit. It can further be deduced that the grain yield at 133 DAS for Season II was greater than that of Season I under all sowing dates except for S3 (Fig 5). The overall grain yield of chickpea in Season I was however better compared to the single harvest of Season II under all sowing treatments except for first sowing time (S1). The grain yields at 133 DAS ranged from 1,573.8 - 1,631.0 and 1,549.8 - 2,235.3 kg/ha at 133 DAS in Season I and II, respectively.

At the 161 DAS harvest, overall grain yield was 1,939.9 - 2,202.1 kg/ha in Season I but none for Season II as the indeterminate growth habit was not exhibited then. These results imply that due to the indeterminate growth habit of *kabuli* chickpea, two harvests of grain are possible for the chickpea crop due to the soil moisture available during the reproductive growth period of the crop, irrespective of sowing dates (Table 11). The abundance of rain during the late phase of the first season may have resulted in the ratoon crop harvest and thus higher grain yields. There were no significant tillage method and sowing time interaction effects on grain yield observed in both seasons by harvest time.

4.2.4 100-Grain weight of *kabuli* chickpea

4.2.4.1 Effects of tillage method on 100-grain weight

The overall mean weight of the *kabuli* chickpea was 39.3g/100-grain in Season I and 38.2g /100-grains in Season II (Table 11). The grain weight of 100 seeds of chickpea ranged from 37.7 to 40.3g and 36.7 to 39.2g in Season I and II, respectively.

It was observed that tillage methods had significant effects ($P < 0.05$) on the 100-grain weight of chickpea seeds in Season I (Table 11). The ST method resulted in significantly lower weight (37.7g) per 100-grains of chickpea compared to the other tillage methods which were at par with each other. The results further depicts that in Season II tillage method had non-significant effects ($P < 0.05$) on 100-grain weight of chickpea.

4.2.4.2 Effects of sowing time on 100-grain weight

The weight of 100-grains of chickpea seed varied between 38.7 and 40.2g in Season I. In Season II the 100-grain weight varied between 37.5 and 39.2g (Table 11). Table 7 depicts that sowing dates had significant effects on the 100-grain weight of chickpea seed in Season I. The S1 sowing date had the greatest weight of 100-grain of chickpea seed compared to the other sowing date treatments that produced similar weights. The sowing treatment effects on 100-grain weight in Season II were similar under all sowing dates (Table 11). There were no significant ($P < 0.05$) tillage method and sowing time interaction effects on 100-grain weight of chickpea seed observed in both seasons.

4.3 Soil Moisture Use by Chickpea

4.3.1 Soil moisture infiltration

4.3.1.1 Effects of tillage method on soil moisture infiltration

The differences in infiltration rates capacity were not statistically different from each other among tillage methods. In Season I, soil moisture infiltration rates between the different tillage methods varied between 6.8 mm hr⁻¹ for conventional tillage and 7.3 mm hr⁻¹ for strip tillage (Table 12). This showed that ST had relatively more enhanced infiltration rate as compared to the other tillage methods while conventional tillage method had the least infiltration rates than the rest. The other tillage methods (double and furrow tillage) had infiltration rate lying in between.

In Season II (June- November) the infiltration rates appeared to be lower possibly due to the prevailing rains just before sowing (Fig 2) and hence high soil moisture contents at the time. The infiltration rates varied between the different tillage methods with a decreasing order of 4.8 mm hr⁻¹ (ST), 4.6 mm hr⁻¹ (DT), 4.5mm hr⁻¹ (CT), and 4.2 mm hr⁻¹ (FT). In Season II, strip tillage permitted relatively more moisture infiltration than all the other tillage methods except furrow tillage by the 35 DAS that resulted in more soil moisture storage and better grain yields (Tables 11 and 12). Generally the d of infiltration rates showed similar trends under tillage methods in both seasons.

Table 12 Effects of tillage method and sowing time on the soil infiltration capacity and rates for the Naivasha soils grown with *kabuli* chickpea in Seasons I and II

Treatment	Infiltration capacity (mm)		Infiltration rates (mm/hr)	
	Season I	Season II	Season I	Season II
Conventional tillage	40.5	27.0	6.8	4.5
Double tillage	42.9	27.8	7.2	4.6
Furrow tillage	41.8	25.4	7.0	4.2
Strip tillage	43.6	29.0	7.3	4.8
lsd	NS	NS	NS	NS
Mean	42.2	27.31	7.0	4.6
First sowing	42.2	27.7	7.1	4.6
Second sowing	40.2	27.8	6.7	4.6
Third sowing	44.2	26.3	7.4	4.4
lsd	NS	NS	NS	NS
Mean	42.2	27.31	7.0	4.6
Coefficient of variation	18.41	13.30	18.25	13.29

Means within the same column followed by the same letter are not significantly different ($P>0.05$) from each other

Legend: lsd = least significant difference

4.3.1.2 Effects of sowing times on soil moisture infiltration

The water infiltration rates of the Naivasha soil were observed to be 7.4 mm hr^{-1} , 7.1 mm hr^{-1} and 6.7 mm hr^{-1} for the third sowing (S3), first sowing (S1), and second sowing (S2), of Season I, respectively (Table 12). In Season II, the infiltration rates were 4.6 mm hr^{-1} , 4.6 mm hr^{-1} and 4.4 mm hr^{-1} , respectively for S2, S1 and S3 sowing treatments, respectively. Water infiltration was observed to be lower in Season II probably due to the prevailing long rains (Fig 2) that made the clayey topsoil wetter and crusted, hence allowed only limited soil moisture infiltration. (Table 12) There were no interactive effects between the tillage methods and the sowing times on soil moisture infiltration rates observed for the Naivasha soils grown with *kabuli* chickpea in both Season I (January-May 2005) and Season II (June-November 2005).

4.3.2 Soil water storage

4.3.2.1 Effects of tillage methods on total profile soil moisture storage

The soil moisture storage of the profiles within the 110 cm depth declined with chickpea growth up to the 91 DAS for all tillage treatments in Season II except for strip tillage (Table 13 and Fig 6). In the first season, however, there was a slight increase in soil moisture by the 119 DAS and at 133 DAS. The rains that came late in this season caused continued flowering and thus the second harvest at 161 DAS. The total profile moisture at sowing time ranged from 486.5 to 488.1mm and 478.1 to 482.5 mm in Seasons I and II while at harvest (133 DAS) the range was 465.2 to 475.2 and 452.7 to 457.4 mm at in Seasons I and II, respectively (Table 13).

The analysis of variance showed that tillage methods had no significant effect on the total soil moisture storage in Season I (Table 13). However, tillage practice had significant influence ($P>0.05$) on total soil moisture storage in the soil profile in Season II at 35 DAS and at 63 DAS (Fig 15), respectively. Here, conventional tillage method resulted in the lowest total soil profile moisture of 477.2 and 472.6 mm at 35 DAS and 63 DAS, respectively. The CT method was however at par with DT and FT at 35 DAS in Season II. Beyond 63 DAS, the differences in stored soil moisture within the profiles under different tillage systems were not significantly different (Table 13).

4.3.2.2 Effects of sowing time on total profile (0-110cm) soil moisture

Soil moisture storage in 110 cm soil profile under all sowing time treatments generally decreased progressively over the period of chickpea growth in both seasons (Fig 7). However, the soil moisture balance increased slightly after 91 DAS due to the rains that came in the second half of Season I. In Season II, however, decline in total soil moisture content (storage) was evident throughout the growing period. The soil moisture storage ranged from 482.4 - 495.0 and 477.2 - 483.1 mm at sowing time to 467.9 - 474.1 mm and 450.3 - 458.7 mm at 133 DAS in Seasons I and II, respectively (Table 13). This gave a difference of moisture content ranging between 14.5 - 20.9 mm and 24.4 - 26.9 mm in the two seasons. There was a sharp decline in soil moisture between the 0 - 35 DAS in both season.

Table 13 Effects of tillage method and sowing time on total soil moisture storage (mm) in the 110 cm soil profile at different growth stages of *kabuli* chickpea

Treatment	Season I (Days after sowing)						Season II (Days after sowing)					
	0	35	63	91	119	133	0	35	63	91	119	133
Conventional tillage	488.1a	472.8a	463.7a	459.8a	460.1a	465.2a	478.1a	477.2b	472.6b	464.6a	457.6a	452.7a
Double digging	487.7a	477.1a	467.1a	463.2a	469.2a	471.9a	482.5a	480.5b	478.7a	462.9a	458.6a	457.4a
Furrow tillage	486.5a	475.3a	466.5a	466.5a	466.1a	475.2a	482.0a	483.5ab	480.7a	464.9a	453.5a	455.0a
Strip tillage	487.8a	475.7a	468.8a	466.1a	469.1a	473.9a	478.8a	488.1a	480.1a	463.8a	456.4a	455.5a
lsd	3.99	4.98	7.51	6.63	9.57	10.99	5.31	6.53	6.10	4.15	4.66	4.80
First sowing	485.4b	480.9a	466.4a	467.4a	467.7a	472.6a	483.1a	485.0a	474.5b	471.4a	457.3a	450.3b
Second sowing	482.4b	475.0b	466.2a	456.7b	466.7a	467.9a	480.6b	478.8a	480.7a	460.6a	452.5b	456.6a
Third tillage	495.0a	469.8c	468.1a	467.7a	464.1a	474.1a	477.2b	483.1a	478.9ab	460.2a	459.8a	458.7a
lsd	3.45	4.31	6.50	5.74	8.29	6.92	4.60	5.65	6.28	3.59	4.04	4.16
Coefficient of variation	0.82	1.05	1.61	1.43	2.05	1.70	1.11	1.35	1.28	0.90	1.02	1.01
Mean	487.5	475.2	466.6	464.1	466.2	471.5	475.2	482.3	478.1	463.9	456.2	455.2

Means within the same column followed by the same letter are not significantly different from each other

Legend: lsd = least significant difference

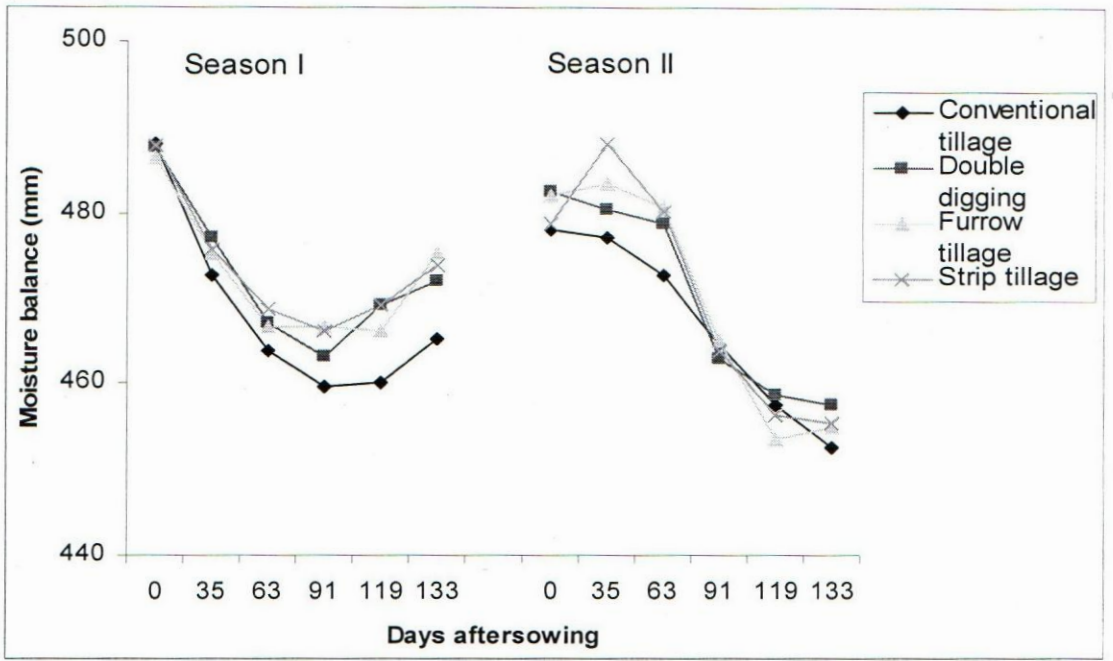

Figure 6 Effects of tillage methods on soil moisture storage during chickpea growth at Naivasha in Seasons I and II

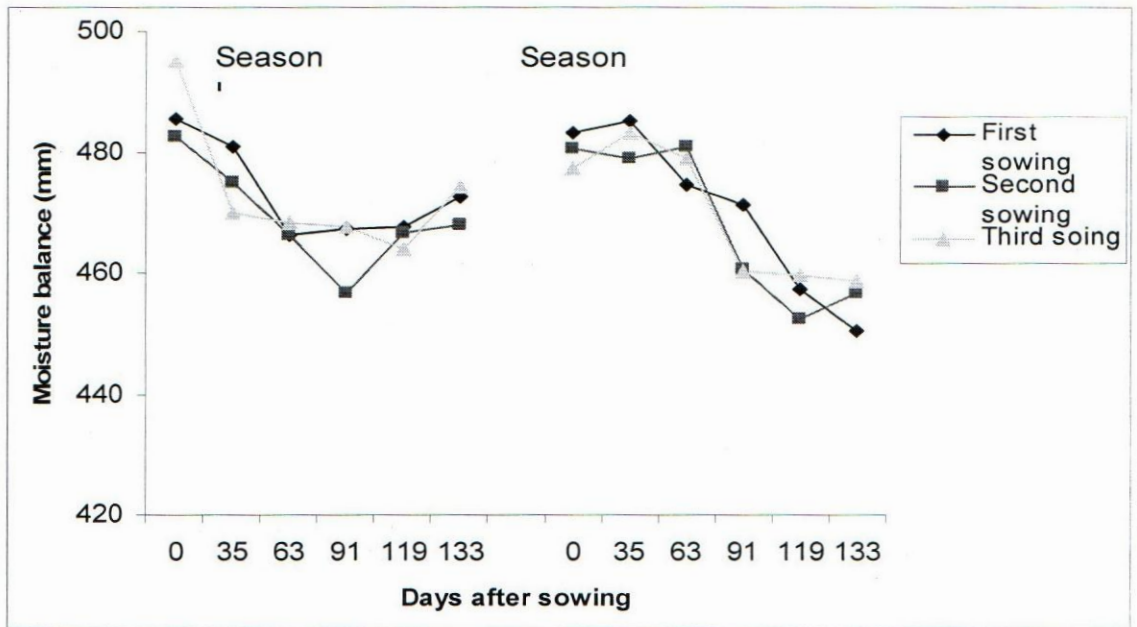

Figure 7 Effects of tillage methods on soil moisture storage during chickpea growth at Naivasha in Seasons I and II

In Season II, first sowing (S1) had more water storage content at sowing time compared to S2 and S3, which were at par (Table 11). This was probably because of the early sowing which benefited early sowing. By 91 DAS in this second season all the soil profiles had similar water contents. At 133 DAS, however, the second (S2) and third (S3) sowings had significantly higher soil moisture contents than that of first sowing (S1).

In both seasons, it was observed that sowing times had significant effects on total soil moisture balance at sowing time and 91 DAS (Table 13) and separately at 35 DAS in Season I, and at 119 DAS and 133 DAS in Season II. The moisture storage was consistently higher for S3 at sowing time and 91 DAS in Season I. At 35 DAS in the first season, S1 experienced the highest soil moisture content of 480.9 mm while S3 had the least with 469.8 mm. In Season II, the moisture contents at 133 DAS were highest for S3 compared to the other sowing times that were at par with each other (Table 13).

For the first sowing time (S1), the overall mean total soil moisture storage decreased to a minimum by the 91 DAS before increasing slowly up till 133 DAS (Table 13 and Fig 7). The rains that came in the second half of Season I caused the soil moisture content to increase, thus recharging the soil water content. In Season II, soil moisture increased at 21 DAS then steadily decreased till 119 DAS followed by a relatively steady state afterwards. During these latter stages of growth, the crop was mature and extracted minimal quantities of water from the soil profile for further growth and development.

4.3.3 Profile moisture storage over time

4.3.3.1 Effects of tillage method on profile moisture storage

The soil profile moisture storage was observed to decrease progressively over the growing phases of chickpea up to 119 DAS in both seasons under all soil profiles (Table 14). By harvest time (133 DAS) there was an increase in the soil moisture storage in the soil profiles due to the rains received towards the end of Season I. The same trend was observed for the total distributed moisture in both seasons except for the 0 - 20 and 90 - 110 cm profiles at 133 DAS in Season I where moisture remained steady or showed a slight increase, respectively. The 60 - 90 cm soil layer stored more moisture (about 30%)

Table 14 Percent profile soil moisture content during the growth of *kabuli* chickpea growth at the KARI-Naivasha in Season I and II

DAS	Moisture content (%) per soil profile depth (cm)									
	Season I					Season II				
	0-20	20-40	40-60	60-90	90-110	0-20	20-40	40-60	60-90	90-110
0	13.4	16.0	20.0	30.5	20.2	13.3	15.7	19.6	30.0	20.0
21	13.6	16.0	19.9	30.3	20.1	13.6	16.0	20.2	30.8	20.5
35	13.6	15.9	19.7	30.5	20.3	13.8	16.1	20.1	30.9	20.5
49	13.8	16.0	19.4	30.4	20.4	13.7	16.3	20.0	31.0	20.7
63	14.0	16.3	19.4	30.1	20.2	14.0	16.5	20.0	31.1	20.9
77	14.1	16.4	19.4	29.9	20.2	14.3	16.6	19.9	30.7	20.6
91	14.3	16.6	19.5	29.7	19.9	14.1	16.2	19.4	30.0	20.2
105	14.2	16.4	19.5	29.9	20.0	14.0	16.0	19.1	29.2	19.6
119	14.1	16.2	19.4	30.0	20.2	14.1	16.2	19.3	29.2	19.5
133	14.0	16.3	19.5	30.1	20.2	13.9	16.1	19.1	28.6	19.2
Mean (%)	13.9	16.2	19.6	30.2	20.2	13.9	16.2	19.7	30.1	20.2
Mean mm/cm depth profile	3.27	3.81	4.60	4.73	4.74	3.26	3.80	4.63	4.73	4.74

Legend: DAS= days after sowing.

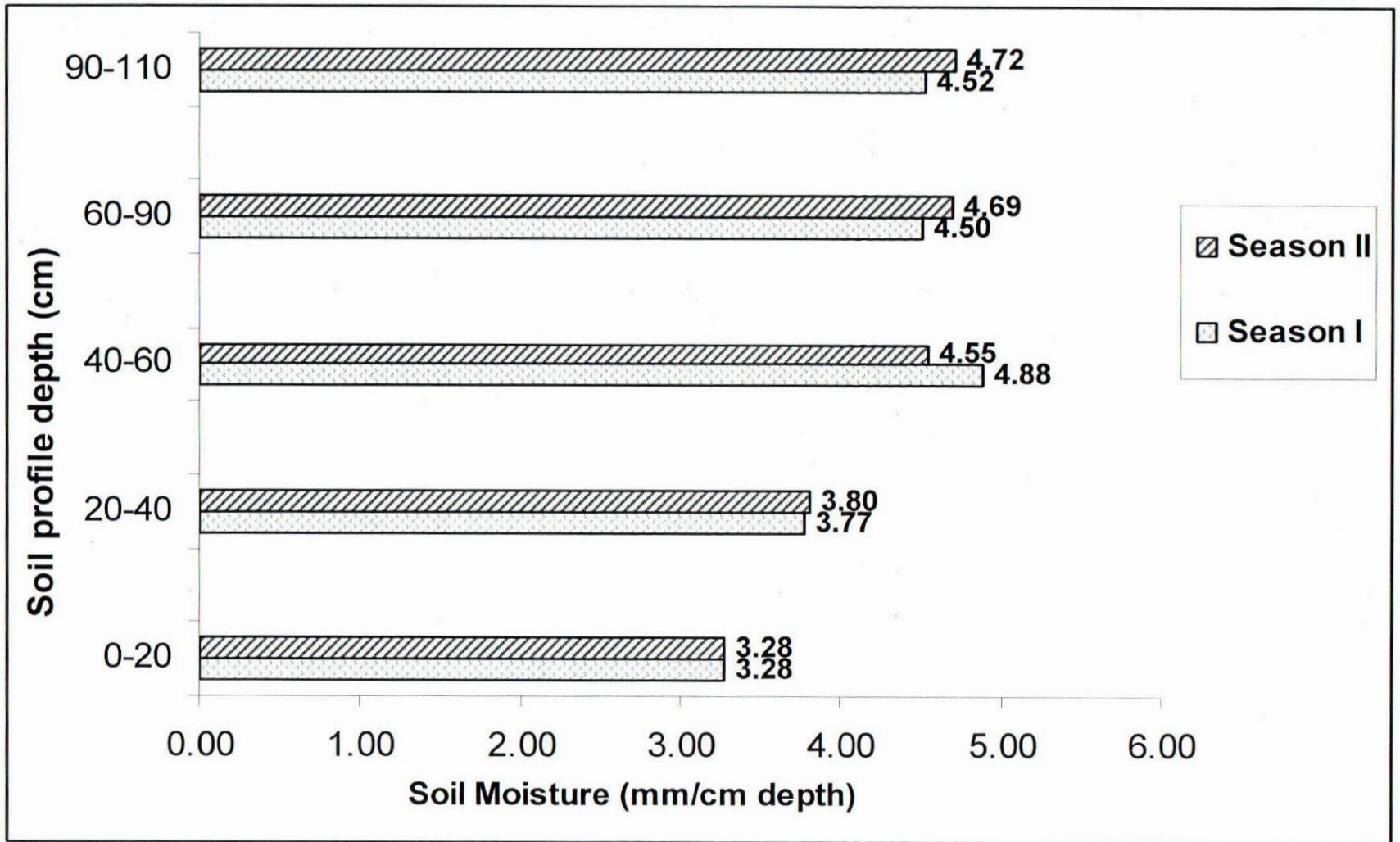

Figure 8 Moisture distribution per unit depth of soil at Naivasha during the growth of *kabuli* chickpea in Seasons I and II

compared to the other profiles while the top 0 - 20 cm layer held the least (about 14.0%) amount of moisture in both seasons (Table 11).

The soil moisture distribution per cm of depth was relatively high and the same for the 60 – 110 cm layers (Table 12). The soil profile moisture storage was lowest the surface (0 – 20 cm) layer and increased progressively with depth to a maximum at the 60 – 90 and 90 – 110 cm profiles in both seasons. A general trend of percent mean soil moisture distribution was observed during the growth of the *kabuli* chickpea at the Naivasha dry highlands (Table 14). It was further noted that the mean soil moisture content, when expressed as percentage of the total available for the 110 cm root zone, remained relatively constant at all depths (Table 14) in the two seasons. This will implied that the proportionate distribution of soil moisture was maintained irrespective of the available soil moisture provided it was at or below field capacity levels for the soils. The low soil moisture content at the surface layer (about 14.0%) would be due to the evaporative demand resulting from the scorching heat and draughts.

The distribution of mean soil moisture (mm/cm depth of soil profile) showed a progressive increase in moisture content with profile depth (Fig 8). The lower soil layers (60 – 110 cm depths) stored more moisture because of the clay loam soils and extraction by the chickpea probably greatest at these profiles. The relative amounts of soil moisture distribution appeared to be more in Season I than in Season II but the weather conditions in the two seasons seem to have had greater influence on the final grain yield (Table 11).

4.3.4 Seasonal Evapotranspiration of Chickpea

4.3.4.1 Effect of tillage method on seasonal evapotranspiration

Seasonal evapotranspiration (ET) was observed to increase successively with maturity of chickpea at KARI-Naivasha under all tillage treatments in both seasons (Table 15 and Fig 9). The ET values increased from 126.1 - 130.8 mm and 94.0 - 105.3 mm by 35 DAS to 321.7 - 338.8 mm and 298.3 - 302.0 mm at harvest time (133 DAS) in Seasons I and II, respectively. The mean values of seasonal ET ranged between 101.3 mm and 127.8 mm

by 35 DAS to 300.1 and 326.8 mm by harvest time in Seasons I and II, respectively (Table 13). The ET at harvest decreased in order from conventional tillage (CT), double tillage (DT) and strip tillage (ST) to furrow tillage in (FT) in Season I but was relatively lower and similar for all tillage methods in Season II (Fig 9).

Seasonal ET showed significant differences by 35 DAS and 133 DAS in Season II and Season I, respectively (Table 15). By 35 DAS in Season II, ST method had the lowest seasonal ET (mm) compared to the other tillage treatments which were however at par with each other. By 133 DAS in Season I, CT method resulted in the highest ET (mm) compared to the other tillage practices, which had similar seasonal ET values for the chickpea crop. However, CT and DT methods gave similar ET values by 133 DAS in Season I.

4.3.4.2 Effect of sowing time on seasonal evapotranspiration

Seasonal evapotranspiration (mm) increased progressively over growing time of chickpea under all sowing date treatments in both seasons (Table 15 and Fig 10). The seasonal ET values ranged from 126.7 - 129.5 mm and 94.3 - 100.9 mm by 35 DAS to 312.1 - 355.6 mm and 291.4 - 309.0 mm by 133 DAS in Season I and Season II, respectively. Seasonal evapotranspiration of the *kabuli* chickpea at harvest under the different sowing times decreased with late sowing dates in Season II but was relatively higher for the second sowing in season I (Fig 10).

The results showed that sowing time treatments caused significant differences ($P < 0.05$) on seasonal ET of chickpea throughout the growing period except at 35 and 77 DAS in Season I (Table 10). By 63 and 91 DAS, S3 and S1 had the least impact on seasonal ET respectively compared to the second sowing date. By 119 and 133 DAS, S1 and S2 respectively resulted in significantly higher ET values ($P < 0.05$) compared to the third sowing date. The seasonal ET values by 119 were statistically different from each other under all sowing time treatments but, by 133 DAS, first sowing (S1) and third sowing (S3) produced similar values ($P < 0.05$) of seasonal ET in Season I (Fig 10).

Table 15 Effects of tillage methods and sowing times on seasonal evapotranspiration of chickpea grown at KARI-Naivasha in Season I and II

Treatment	Season I (DAS)						Season II (DAS)					
	35	63	77	91	119	133	35	63	77	91	119	133
Conventional tillage	130.8a	155.4a	177.6a	223.4a	281.3a	338.8a	104.1a	183.7a	205.2a	221.7b	288.3a	300.3a
Double tillage	126.1a	151.6a	172.3a	218.0a	271.9a	327.2ab	105.3a	182.1a	203.4a	227.9a	291.8a	299.9a
Furrow tillage	126.7a	150.8a	171.7a	215.4a	272.8a	321.7b	101.8a	179.5a	198.7a	225.4a	296.3a	302.0a
Strip tillage	127.5a	149.9a	171.2a	213.6a	272.1a	324.4b	94.0b	177.0a	196.9a	223.3a	290.3a	298.3a
Lsd	6.90	8.00	7.55	11.67	10.09	8.29	7.67	7.41	8.79	6.69	8.27	5.94
Mean	127.8	151.9	173.2	217.6	274.5	326.8	101.3	180.6	201.1	224.6	291.7	300.1
First sowing	126.7a	156.4a	171.0a	186.3a	296.8a	312.1b	94.3b	179.6b	203.8a	220.2a	291.4a	309.0a
Second sowing	129.5a	154.7a	175.8a	235.2a	285.7b	355.6a	108.6a	170.6c	198.1a	228.2b	293.2a	300.0b
Third sowing	127.2a	144.4b	172.7a	231.4a	241.1c	312.6b	100.9b	191.6a	201.3a	225.2c	290.2a	291.4c
Lsd	5.97	6.93	6.54	10.10	8.74	7.18	6.64	6.45	7.61	4.93	5.43	5.15
Coefficient of variation	5.40	5.27	4.36	5.36	3.68	2.54	7.58	4.10	4.36	2.54	2.15	1.98
Mean	127.8	151.9	173.2	217.6	274.5	326.8	101.3	180.6	201.1	224.6	291.7	300.1

Means within the same column followed by the same letter are not significantly different ($P < 0.05$) from each other

Legend: lsd = least significant difference; NS = not statistically significant

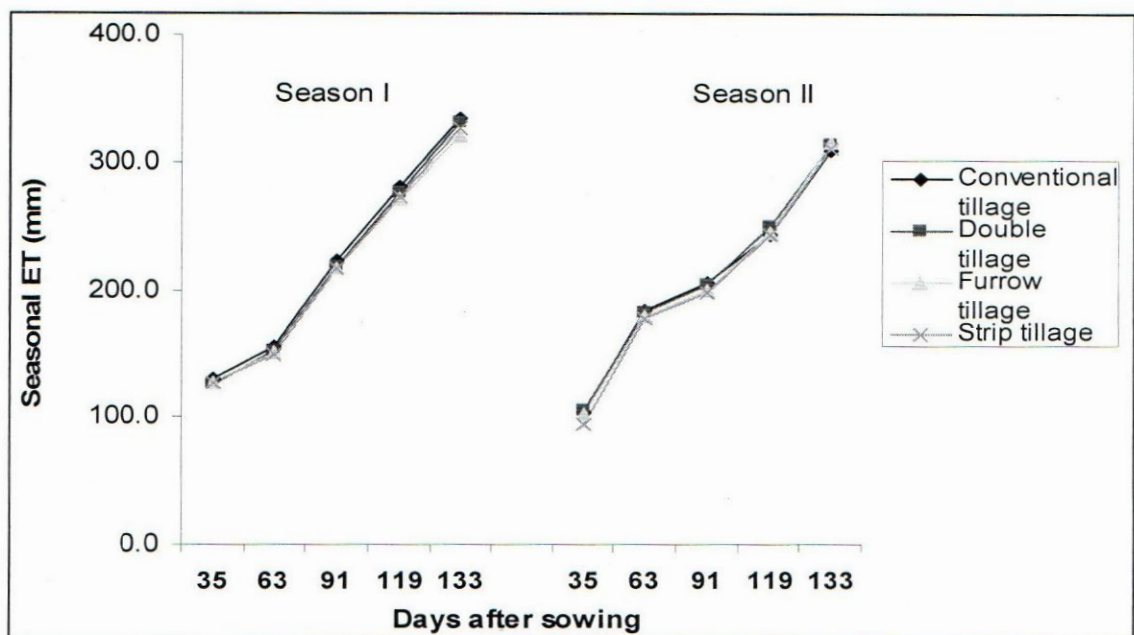

Figure 9 Effects of tillage methods on seasonal evapotranspiration of *kabuli* chickpea grown at Naivasha in Seasons I and II

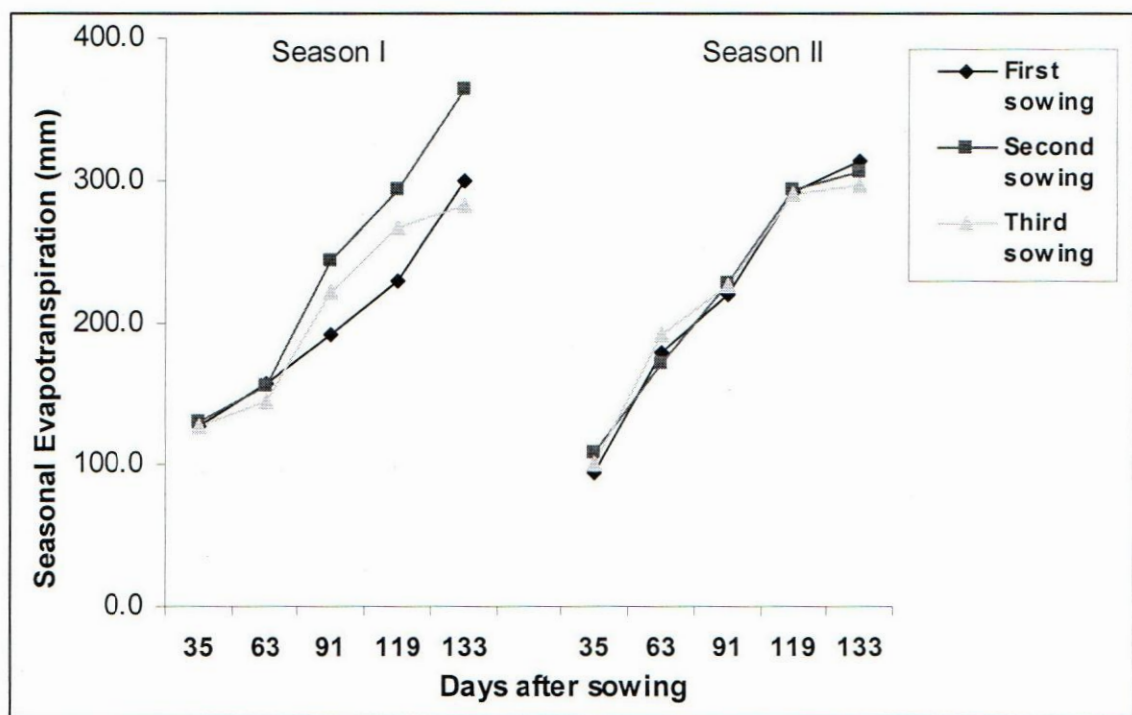

Figure 10 Effects of sowing times on seasonal evapotranspiration of *kabuli* chickpea grown at Naivasha in Seasons I and II

The cumulative ET of S1 was at par with that of S2 by 63 DAS and produced the lowest seasonal ET at 91 DAS in Season I compared to the other sowing dates which were at par with each other. The results show that the second sowing time (S2) and the third sowing time (S3) sowing dates by 91 DAS resulted in statistically similar seasonal ET values compared to the S2 (108.6 mm) and S1 (220.2mm), respectively.

4.3.4.3 Tillage and sowing time interactive effects on seasonal evapotranspiration

The interactive effects of tillage method and sowing time on seasonal ET of chickpea (Table 16) were significantly different at all growth stages of the crop in Season II only.

The results indicate that S1 interactions between conventional tillage (CT) with second sowing (S2) and furrow tillage (FT) with first sowing (S1) gave the highest and the lowest seasonal ET values respectively compared to the other tillage method and sowing time interactions by 35 DAS. However, CT x S2 had similar seasonal ET with FT x S2, DT x S3 and DT x S1 interactions. The rest of the tillage methods and sowing times interactions had seasonal ET values at par with each other by the same period in this second season.

By 63 DAS, the tillage method and sowing time interactive effects on seasonal ET of DT x S3 (200.0mm) and CT x S3 (192.1mm) treatments differed significantly from time in Season II (Table 16). However, interaction between conventional tillage and first sowing date (DT x S1) resulted in similar interactive effects on seasonal ET of the chickpea under all the other tillage and sowing time interactive combinations. The seasonal ET ranged from 236.0mm to 206.8mm by 91 DAS (Table 16).

The interactive effects of tillage method and sowing time on seasonal ET by 119 DAS revealed that combinations between conventional tillage with second sowing (CT x S2) was statistically superior compared to strip tillage with third sowing time (ST x S3), conventional method with third sowing time (CT x S3), double tillage with second sowing time (DT x S2) and conventional tillage with first tillage (CT x S1) for the chickpea grown during Season II (Table 16). The other interactive combinations on the seasonal evapotranspiration (ET) were non-significant in this second season.

Table 16 Interactive effects of tillage method and sowing time on the seasonal evapotranspiration of *kabuli* chickpea in Season II

Interaction combination	Days after sowing in Season II				
	35	63	91	119	113
Conventional tillage x First sowing	91.3d	174.2cd	206.8d	279.7d	299.7bcd
Conventional tillage x Second sowing	120.0a	184.9abc	236.0a	300.9a	312.1ab
Conventional tillage x Third sowing	101.3bcd	192.1ab	222.3bc	284.4cd	289.2ab
Double digging x First sowing	104.7abcd	189.8abc	232.0ab	296.7abc	314.6a
Double digging x Second sowing	101.3bcd	156.5c	222.5bc	283.6cd	290.7cd
Double sowing x Third sowing	109.8abc	200.0a	229.1abc	295.1abc	294.5cd
Furrow tillage x First sowing	90.1d	174.5cd	218.3c	294.9abc	311.7ab
Furrow tillage x Second sowing	116.2ab	176.2cd	231.1ab	298.1ab	302.7abc
Furrow tillage x Third sowing	99.1cd	187.9abc	226.6abc	295.9abc	292.3cd
Strip tillage x First sowing	91.2d	179.7bcd	223.8bc	294.2abc	309.9ab
Strip tillage x Second sowing	97.0cd	165.0de	223.3bc	291.0abcd	295.3cd
Strip tillage x Third sowing	93.8cd	186.4abc	222.9bc	285.7bcd	289.6bcd
DMRT	15.34	14.81	11.38	12.53	11.89
Coefficient of Variation (%)	7.58	4.10	2.54	2.15	1.90

Means within a column followed by the same letter are not significantly different at 0.05 level of probability

Legend: DMTR = Duncan's multiple range test

The results indicated that seasonal ET ranged from 300.9mm to 279.7mm by 119 DAS in this season. Treatment combinations between double tillage with first sowing (DT x S1) and conventional tillage with third sowing (CT x S3) interactive effects respectively revealed the highest and lowest seasonal ET of the chickpeas by 133 DAS in Season II only (Table 16). However, double tillage with first sowing (DT x S1) had similar tillage method and sowing time interactive effects on seasonal ET with combinations of CT x S2, FT x S1, ST x S1 and FT x S2 interactions. The seasonal ET varied between 314.6mm and 289.2mm by this time of growth.

The tillage method and sowing time interactive effects of CT x S2 and DT x S1 on seasonal ET were observed to differ significantly from CT x S1 by 91 DAS to harvest ST x S2 (165.0mm) and DT x S2 (156.5mm) in Season II by over 35mm water use per hectare of chickpea (Table 16).

4.3.5 Water Use Efficiency of Chickpea (Biomass Basis)

4.3.5.1 Effects of tillage method on water use efficiency (biomass basis)

The water use efficiency biomass basis (WUE_b) was observed to increase progressively with maturity of chickpea under all tillage treatments (Fig 11). It varied from 0.60 - 0.79 and 0.66 - 0.74 kg ha-mm⁻¹ at 35 DAS to 9.76 - 13.30 and 10.08 - 16.07 kg/ha-mm at harvest in Season I and Season II, respectively (Table 17).

The WUE_b differed significantly throughout the growing stages of the crop under all tillage treatments in Season I. Conventional tillage method in the first season produced consistently lower WUE_b values compared to the other tillage treatments that were at par with each other. In Season II, the effect of tillage method on WUE_b was statistically significant at the later stages of chickpea growth, i.e., at 77 and 133 DAS. At these two stages of growth, ST method gave superior WUE_b compared to the other tillage treatments (Table 17). However, ST resulted in similar WUE_b with the DT method at 133 DAS. The other tillage methods (CT, DT and FT) had similar effects on WUE_b at 77 DAS in the second season. The interaction effects of tillage method and sowing time on the water use efficiency (biomass basis) was not significantly different.

4.3.5.2 Effects of sowing method on water use efficiency (biomass basis)

Sowing time of chickpea had no significant influence on WUE_b in Season I except at 133 DAS at all stages of growth (Fig 10). At this time of chickpea growth, which coincided with the crop's main final harvest in the first season, S3 gave the highest WUE_b compared to the other sowing dates. There was no significant difference in WUE_b between the first and second sowing time (Table 17). In the second season, sowing time effects on total WUE_b were significantly different up-to 77 DAS. By harvest time (133 DAS) the WUE_b values were similar under all sowing treatments in Season II (June-November 2005).

It was also noted that S3 consistently resulted in the least WUE_b of chickpea at 35, 63 and 77 DAS compared to the other sowing dates in both seasons (Table 17). However, the WUE_b due to S3 was similar to that of S2 at 35 DAS and S1 at 77 DAS, respectively. At 63 DAS, S1 and S2 had similar WUE_b values that were superior to that of S3. Tillage methods and sowing times interaction effects on water use efficiency (WUE_b) were observed to be non-significant in both seasons.

4.3.6 Water Use Efficiency (Grain yield basis)

4.3.6.1 Effects of tillage method on grain water use efficiency

Effects of tillage on the grain based water use efficiency (WUE_g) by chickpea were observed to range from 4.33 - 5.58 and 4.94 - 8.56 kg ha-mm⁻¹ of water used in Season I and Season II, respectively (Table 18). The weather conditions during the two seasons may have caused the differences in WUE_g . Strip tillage gave significantly higher WUE_g compared to the other tillage methods which were statistically similar with each other. Strip tillage method, however, resulted in relatively better compared to the other tillage treatments in Season II. The results further showed that tillage methods caused significant differences on WUE_g in Season I but the differences were significant at $P < 0.05$ in Season II (Table 18).

Table 17 Effects of tillage method and sowing time on water use efficiency (biomass basis, kg/ha-mm) of *kabuli* chickpea grown at the KARI-Naivasha in Seasons I and II

Treatment	Days after sowing (Season I)				Days after sowing (Season II)			
	35	63	77	133	35	63	77	133
Conventional tillage	0.66a	3.96b	8.37b	9.76b	0.66a	3.17a	6.60bc	10.63b
Double digging	0.71ab	5.98a	12.59a	12.20a	0.66a	3.60a	7.80b	12.08ab
Furrow tillage	0.70ab	5.83a	12.33a	13.30a	0.68a	3.31a	5.59c	10.08b
Strip tillage	0.79a	6.47a	13.43a	13.08a	0.74a	3.86a	9.36a	16.07a
Lsd	0.11	1.42	3.40	2.34	0.11	1.31	1.51	4.21
First sowing	0.75a	5.71a	12.51a	12.50ab	0.76a	3.68a	7.33b	14.61a
Second sowing	0.66a	5.51a	11.48a	10.60b	0.65b	4.51a	9.30a	11.23a
Third sowing	0.70a	5.46a	11.05a	13.13a	0.64b	2.27b	6.13b	10.80a
Lsd	0.09	1.23	2.94	2.03	0.10	1.14	1.31	3.85
Coefficient of variation	15.25	25.45	29.10	19.36	16.8	37.67	19.93	34.53
Mean	0.70	5.56	11.68	12.09	0.68	3.48	7.59	12.21

Means within a column followed by the same letter are not significantly different at $P < 0.05$ level of probability

Legend: lsd = least significant difference

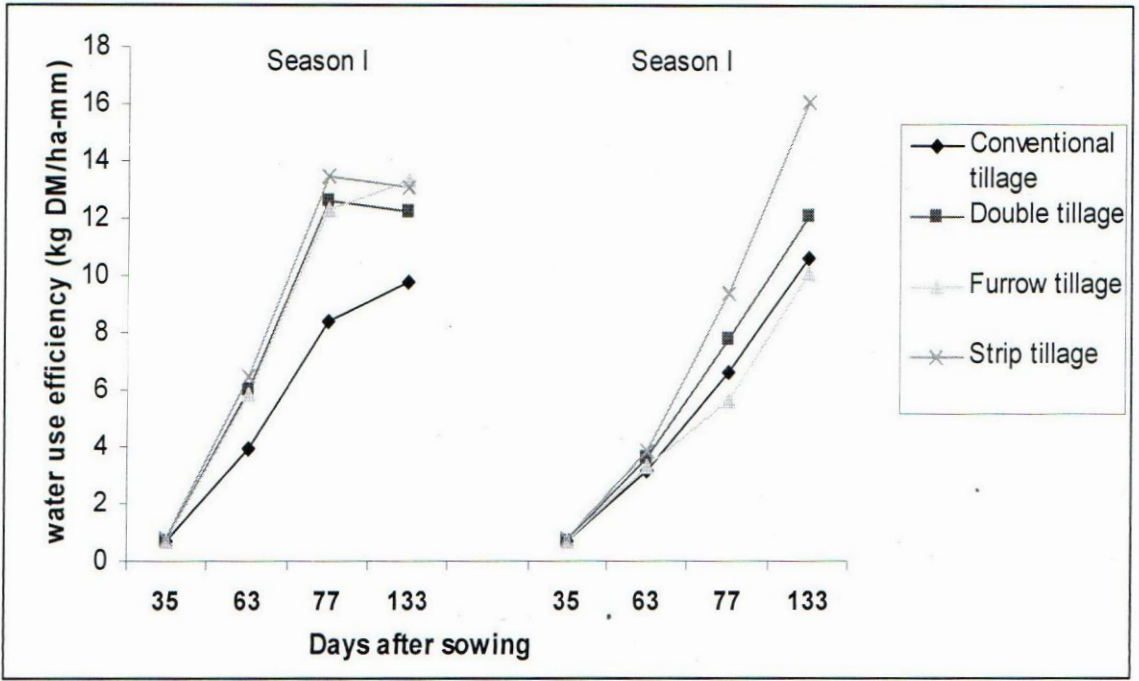

Figure 11 Effects of tillage methods on water use efficiency biomass basis of *kabuli* chickpea grown at Naivasha in Seasons I and II

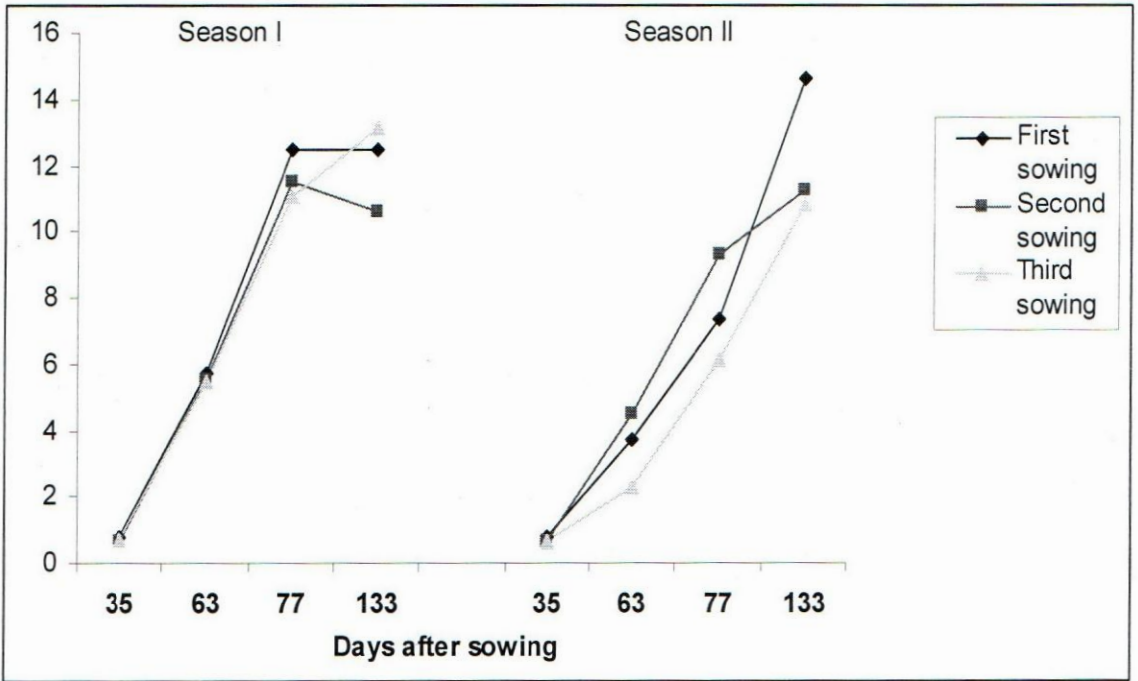

Figure 12 Effects of sowing times on water use efficiency biomass basis of *kabuli* chickpea grown at Naivasha in Seasons I and II

4.3.6.2 Effects of sowing time on water use efficiency of chickpea (grain yield basis)

The grain water use efficiency (WUE_g) of chickpea at 133 DAS ranged from 4.42 - 5.22 and 5.33 - 7.22 $kg\ ha^{-1}\ mm^{-1}$ of water used in Seasons I and II, respectively (Table 18). The sowing time effects on chickpea's WUE_g at 133 DAS were statistically significant in Season II only. Here, first sowing (S1) resulted in superior WUE_g compared to the other sowing treatments, which were however at par with each other. The first sowing (S1) had similar WUE_g with second sowing (S2) planted a week later. Tillage method and sowing time interactive effects on the grain based water use efficiency (WUE_g) of *kabuli* chickpea were non-significant at $P < 0.05$ in both seasons (Table 18).

4.3.7 Moisture use rate by kabuli chickpea.

4.3.7.1 Effects of tillage method on moisture use rate by chickpea

The results of Table 18 depicts that the tillage method had no significant interactive effects on the overall moisture use rate (MUR) in Season I. The MUR was non-significant under tillage treatment effects and ranged between 2.31 – 2.40 mm/day in Season I. In Season II, tillage treatment methods showed significant differences ($P < 0.05$) on the MUR with DT and ST resulting in the highest values of 2.56 mm/day each.

4.3.7.2 Effects of sowing time on moisture use rate of chickpea

The moisture use rate (MUR) in Season I (January-May 2005) ranged from 2.23 to 2.58 mm/day and 2.18 to 2.32 mm/day which resulted in significant differences ($P < 0.05$) under sowing time treatments (Table 18). The MUR was observed to decrease with the late sowing in Season II.

Table 18 Effects of tillage methods and sowing times on grain water use efficiency (kg ha-mm⁻¹) and moisture use rate (mm/day) of *kabuli* chickpea grown at Naivasha in Seasons I and II

Treatment	Water use efficiency (Kg Grain ha-mm ⁻¹)		Moisture use rate (mm/day)	
	Season I	Season II	Season I	Season II
Conventional tillage	4.33	4.94	2.40	2.27b
Double tillage	4.94	6.14	2.36	2.56a
Furrow tillage	4.86	5.61	2.33	2.56a
Strip tillage	5.58	8.56	2.31	2.23b
lsd	1.74	NS	NS	0.06
First sowing	5.15	7.22	2.23b	2.32a
Second sowing	4.42	6.38	2.58a	2.25b
Third sowing	5.22	5.33	2.28b	2.18c
lsd	0.99	NS	0.06	0.05
Coefficient of variation (%)	23.18	24.43	2.92	2.62
Overall mean	4.93	6.31	2.35	2.25

CHAPTER FIVE

5.0 DISCUSSION

5.1 Chickpea growth under varying tillage methods and sowing time

5.1.1 Chickpea growth attributes under varying tillage methods

Irrespective of tillage practices imposed on *kabuli* chickpea, height was observed to increase with maturity of the crop to a maximum of 42 to 47 cm in both seasons (Table 5). This was in agreement with the findings of Hardman *et al.* (1990) who reported chickpea plant height ranging from 20 to 100 cm tall. Work in India revealed that plant height of chickpea varies from 40 to 54 cm (Kumar *et al.*, 2001). Dry matter (DM) accumulation also increased with maturity of chickpea under all tillage treatments to a maximum range of 3,242 to 4,231 kg DM ha⁻¹ in Season I and from 3,035 to 4,556 kg DM ha⁻¹ in Season II. Similar DM production by Indian chickpea had been reported by Saxena (1984) who noted DM production range of 2,950 to 6,800 kg DM ha⁻¹ while 4300 to 4,800 kg DM ha⁻¹ was reported by Kumar *et al.* (2001).

Leaf area index (LAI) increased to a maximum range of 2.50 to 3.31 in Season I and from 4.22 to 5.44 in Season II by 91 DAS (Table 6). Beyond this stage of chickpea growth LAI was observed to decline to a range between 1.68 to 2.13 in Season I and 1.02 to 1.20 in Season II by 119 DAS in both seasons. This was attributed to leaf fall and concurred with earlier findings of Kumar *et al.* (2000) who noted that LAI, plant height and functional canopy increased with time of growth though LAI decreased over the latter measurements because of leave senescence. The relatively greater LAI observed in Season I under all tillage treatments were due to the continued growth of the crop caused by the rainfall incidence that occurred later in the season. The crop was able to yield extra grains because of this indeterminate growth habit (Table 11).

5.1.2 Chickpea growth attributes under varying sowing times

Treatment effects of sowing time on plant height, LAI and DM production were observed to increase with crop maturity (Table 5, 6, and 7). Third sowing (13th January- 26th May 2005) gave significantly ($P < 0.05$) taller plants and higher LAI than second and third sowing, respectively. Third sowing (S3) of Season I had taller plants and higher LAI

probably because it coincided with higher amounts of available soil moisture, and better distributed rainfall than in the case of other sowing dates. Dry matter accumulation at all stages of growth, however, revealed no significant differences between the three sowing date treatments in Season I.

Measurement of LAI has been reported to be critical to understanding many aspects of crop growth, development, water use and management (Wilhelm *et al.*, 2000). Kumar *et al.* (2000) observed that availability of higher amounts of moisture during various stages of crop growth with moisture conservation practices resulted in better crop growth (plant height and LAI), higher amounts of DM production and its translation to branches and thus grain yield (Tables 7 and 11). On the other hand Harman *et al.* (1990) noted that later planting dates result in shorter plants, less yield and late maturity of late formed flowers and pods. In the current study during Season II, the third sowing had relatively shorter plants by 63 DAS but was at par with other sowing date crops by 91 and 119 DAS. With regard to LAI and DM production, S1 had higher values than S3. This could be explained by the fact that there was more rainfall (58.5 mm) over the initial growing period of Season II (Table 2). Therefore, the later sowings (S2 and S3) crop received less amounts of water resulting into lower LAI, DM production and final grain yield as indicated earlier.

Chickpea is known to be a cool season crop (Nielson *et al.*, 1999) and therefore, the lower temperatures (max. 21⁰C and min. 10⁰C: Fig 3) that prevailed in Season II (June 26 to November 8, 2005) during the branching period of the crop would have contributed to the relatively better grain yield (1.9 – 2.5 ton ha⁻¹). The corresponding mean grain yield in Season I ranged between 1.5 – 1.7 ton ha⁻¹. This implies that Season II weather conditions over the critical chickpea stage period (branching and 50% flowering – 61 DAS) was more conducive for enhancing yield than was the case for the Season I crop. Further studies to investigate and quantify rates of yield increments as affected by temperature, water availability and their interactions at various stages of chickpea growth is therefore recommended.

5.2 Effects of tillage method and sowing time on chickpea maturity attributes

5.1.1 Time to first flower

Flowering is reported to be a major adaptive trait material to survival and cultivation (Marx, 1985). It is estimated that major biotic and abiotic stresses reduce at least 50% realizable potential yield of this crop in the major production areas of the world (Ryan, 1997). Much of these losses occur at flowering and podding time during February/March in India when mean temperatures are high and the days are long but can be avoided if chickpea can be harvested early (Kumar *et al.*, 1996). They report that flowering and reproduction occur in the late spring and attain 50% flower for Mediterranean environments between 130 to 136 DAS. The crop's natural drought resistance makes it eminently suitable for semi-arid environments (Kumar and Abbo, 2001). They also noted that timing of flowering independent of day length usually means that the plant would enter reproduction upon accumulation of a certain biomass (often expressed as number of internodes) typical to the genotype.

In the present study the time *kabuli* chickpea took to first flower and 50% flowering were not affected by tillage method and sowing time treatments (Table 8) in both seasons. The first flowers were observed to appear between a mean of 33 and 36 DAS in both seasons with maximum and minimum temperature ranges of 26 to 32°C and 11 to 17°C in Season I and 19 to 25°C and 9 to 14°C in Season II, respectively. The relatively lower temperature ranges in Season II may have caused the chickpea crop to take a slightly longer time to first flowering (Table 8). Work by ICRISAT in India showed that days to first flower varies between 24 (ICCV 96029) to 61 (C 235) DAS at Patancheru (18°N) and 43 (ICCV 96029) to 83 (Pant G 114) DAS at Hisar (29°N) depending on the chickpea cultivar (Kumar *et al.*, 1996). They concluded that these findings show genes controlling flowering time to be sensitive to temperature and day length. The small range of time to first flower in the two seasons of the present study is a confirmation that this is true for the current study. The number of days taken from sowing to onset of flowering (flowering time) is a major component of crop adaptation, particularly in rain fed environments (Subbarao *et al.*, 1995). The timing of flowering is dependent upon the genotype, the seasonal temperature profile, photoperiod, and vernalization responses of

the plants: temperatures above 30°C have, however, been reported to inhibit flowering by Kumar and Abbo (2001). An understanding of the effects of these factors and their interactions on chickpea flowering and yield is therefore necessary in Kenya.

5.2.2 Time to 50% flower

The mean time to attain 50% flowering in the present work was at 61 DAS in both seasons irrespective of tillage and sowing treatments and showed no significant differences. It ranged from 60.1 to 64.1 DAS in Season I and 59.6 to 63.6 DAS in Season II under the various tillage treatments. The mean time to 50% flowering range was from 57.5 to 64.8 DAS in Season I and 56.9 to 64.8 DAS in Season II under varying sowing dates. Work by ICRISAT (1985) for 25 genotypes revealed that the time to 50% flower to be 95.6 DAS at Hisar (29°N), 75.5 DAS at Gwalior (26°N) and 51.3 DAS at Patancheru (18°N). Geographical locations affect flowering time of chickpea as observed in the ICRISAT study. This implies that the closer to the equator, the shorter the time taken to 50% flowering by chickpea. It can be concluded that *kabuli* chickpea IIV95423 is highly adaptable to Naivasha environments and the flowering period and duration is not significantly affected by tillage and sowing dates.

5.2.3 Time to physiological maturity

The time to physiological maturity (where over 50% pods were yellow) for *kabuli* chickpea in Naivasha was approximately 120 DAS (Table 6). However, with continued rains in Season I, production of branches, flowers and pods by chickpea continued up to after 145 DAS producing extra grain yields by 23.3 to 35.0% (Table 9) above that produced by 133 DAS. This concurred with reports by Anwar *et al.* (2000). The time to physiological maturity is reported to range from 79 to 155 DAS by Kumar *et al.*, (1996) depending on the location and genotype. The current study on *kabuli* chickpea (ICCV 95423) was within this range. On the Indian subcontinent the growing season is limited to a range of 90 to 130 DAS due to increasing temperatures and reduced soil moisture (Saxena *et al.*, 1993). Early planting when the soil moisture profile is fully charged is advantageous but prevailing high temperatures in the tropics could adversely affect the

final seed yield (Kumar and Abbo, 2001). These researchers recommend early maturity to help alleviate the major constraints to productivity of the chickpea which include drought and poor management. Advancing sowing date as a way of increasing yields in East Africa will enable the crop to have more moisture for early growth and thus produce more biomass (Kumar and Abbo, 2001). This was confirmed in the current study where earlier sowing resulted in higher biomass and grain yield (Tables 7 and 11) as compared to the later sowings, particularly in the June to November 2005 (Season II) sowings. The relatively high temperatures in Season I stressed the crop in early stages of growth.

5.3 Yield and yield attributes of *kabuli* chickpea

Grain yields of *kabuli* chickpea ranged from 1,430.6 to 1,798.1 kg ha⁻¹ in Season I and 1,489 to 2,545 kg ha⁻¹ in Season II under the various tillage methods and sowing times. The effects of both tillage method and sowing time treatments on grain yields in both seasons were non-significant (Table 11). In Season I, however, the indeterminate growth habit of chickpea was evident due to the continued rainfall received (Table 2). This resulted in grain yield increment of between 26 to 30% as a result of tillage treatments and 23 to 35% grain increments as a result of varying sowing times. This signifies the importance of incident rainfall on soil moisture storage and utilization for growth and yield by chickpea. Anwar *et al.* (2000) reported significant correlations ($r^2=0.73$) between water use and seed yield. The yields obtained in this study were, therefore, within the ranges reported earlier by Nielson (2001) ranging 951 – 3,500 kg ha⁻¹ and by Miller *et al.*, 2002 ranging from 290 – 3,400 kg ha⁻¹.

The total number of branches/plant and pods/plant were higher where greater grain yield was obtained (Tables 10 and 11), implying a positive correlation between these attributes on grain yield of chickpea. The number of branches per plant increased with maturity of the crop to attain a maximum by 119 DAS in both seasons and under both tillage method and sowing date treatments. Strip tillage (ST) had the highest total number of branches per plant at all stages of chickpea growth in both seasons (Table 10). Similarly, the number of pods per plant at harvest (ranging between 61-70 in Season I and 131-150 in Season II) was also highest under strip tillage practice as was the 100-grain weight (37 -

40 g) at final harvest. Thus, grain weight was observed to be relatively higher, though not significantly, under ST compared with other tillage methods. Kumar and Abbo (2001) reported a range of 20 to 68 g for every 100-seed of *kabuli* chickpea for tropical India. Therefore, higher total number of branches/plant, number of pods/plant and 100-seed weight were observed to result into relatively higher grain yields (Tables 10 and 11) in this study.

The second season grain yields were relatively higher compared to than that of Season I probably because of the higher number of pods/plant in Season II. This was possibly due to the prevalent conducive weather, i.e., rainfall and temperature (Table 1) during the growing period. This could be explained by the fact that chickpea begins and completes its life cycle under increasing photoperiod and rising temperatures and depends mainly on stored soil moisture (Khanna-Chopra and Sinha, 1987) as this was observed in the second season (Table 13). Work by Anwar *et al.* (2000) showed that irrigation applied during post-flowering gave significant seed yield increases with soil moisture depletion confined to 80 cm. This would explain continued growth and increased yields of the crop observed in the late growth period following the rains received then in Season I.

Lower rainfall availability in Season I during flowering and branching and pod filling (about 50 - 60 DAS) affected flowering and podding (Table 2). Thus Season I crop (January – May, 2005) had fewer number of pods/plant but a relatively higher 100-grain weight. This was in agreement with the findings of Keatinge and Cooper (1983), Saxena (1984), Saxena (1987) and Oweis *et al.*, (2003).

5.4 Effects of tillage method on infiltration rate

The treatment effects on infiltration rates, derived from soil moisture content in soil profiles between the time before first rainfall incidence and 48 hours afterwards, were not significantly different at $P < 0.05$ level of confidence (Table 12).

In the current study infiltration rates measured were found to be relatively higher for strip tillage (ST) compared to the other tillage methods but not significantly different (Table

10). Conventional tillage method recorded the lowest infiltration rates in both seasons. This would be due to the disturbance imposed on the soil by CT thus pulverizing the surface soil to enhance crusting as observed by earlier works noted above. Strip tillage had vegetation that provided root systems and organic matter in the soil and on the surface which increased the soil porosity and facilitated infiltration (Thomas, 1997) in both seasons. Vegetation also retards surface flow on gentle slopes giving water more time to infiltrate or evaporate. The effects of relatively higher infiltration rates translated to greater soil moisture storage for strip tillage, ensuring moisture availability for the chickpea to utilize and thus, produce more grain yields in both seasons (Table 11). It is therefore recommended that strip tillage be used in Naivasha soils for chickpea production as it enhances moisture infiltration, storage and ultimate utilization for higher yields.

This work showed that infiltration rates in the second season (June – November 2005) were relatively lower than those recorded for Season I (Table 12) probably because of the prevailing rains. This is in line with the investigations which have shown that infiltrations are less for pre-wetted surfaces than for dry ones due to the full development of the surface seal by the breakdown that occurs during pre-wetting (Le Bissonnais and Singer, 1992). Bare ground can yield high rates of runoff and in an experiment with 20 m² runoff plots in Mukogodo, Laikipia district, 50% of all the rain that fell on bare rangeland became runoff (Thomas, 1997). This may have been the case for the conventional tillage (CT) method that showed low infiltration rates as it was quite bare with resulting low moisture storage and low yields in both seasons. Bare soils in semi-arid environments are known to encourage runoff loss and low infiltrations that are accompanied by surface crusting (Connolly *et al.*, 1998). The infiltration dynamics is reported to be the most important hydrological process within a watershed (Thomas, 1997).

5.5 Effects of tillage and sowing time on soil moisture storage

The soils exhibited varying water storage capacities within its different profile depths (Table 13). The field capacity (FC) and wilting point (WP) were determined to be 647.4 mm and 397.3 mm, respectively. The soil moisture storage for the soil was within this

range at all times of chickpea growth thus the soil moisture (Table 13) was above wilting point. The maximum bulk density of 1.36 g cm^{-3} was observed to be in the 20 – 40 cm profile depth. The potential available soil moisture was 250.1 mm within the profile under study, translating to 227.4 mm per metre depth of soil.

5.5.1 Soil moisture storage under varying tillage methods

The role of appropriate tillage in dry lands is to provide a suitable environment for seed germination, root growth, weed control and moisture control avoiding excesses and reducing moisture stress (Mayande, 1995). In the current study, conventional tillage (CT) appeared to store relatively less soil moisture at the critical flowering stage of chickpea. By 63 DAS, conventional tillage (CT) method caused the lowest soil moisture infiltration, thus only 472.6mm water stored in the 110 cm soil profile. Soil moisture storage during the other stages of growth was no statistically significant ($P < 0.05$). This probably meant that CT did not enhance higher percolation and thus storage of water in the soil profile in the initial 63 days in Season II. Later stages of crop growth revealed similar water storage abilities as influenced by tillage systems. This was probably because the soil structure had settled and regained the normal state. Tillage had more influence on soil water storage on the initial days after sowing. Tillage method effects on soil moisture content (mm) remained similar throughout the growing period in Season I. In Season II, however, strip tillage permitted more infiltration than all the other methods except furrow tillage at 35 DAS

Strip tillage conserved more moisture, allowed less ET (Table 15) and consequently availing more moisture for production of more branches/plant (Table 10). This resulted in relatively greater LAI (Table 6) ultimately producing significantly more aboveground DM (Table 7) , pods/plant, 100-grain weight and final grain yields (Table 11) at later stages of growth than the other tillage treatments. Conventional tillage (CT) and double digging (DT) appeared to be relatively poorer soil moisture conservation practices probably because the soil was disturbed more compared to strip tillage. The furrow tillage compared well with strip tillage in terms of moisture storage because it was able to encourage infiltration probably by holding water in the furrows for longer periods.

5.5.2 Soil moisture storage under varying sowing times

More stored soil moisture (Table 13) does not necessarily translate into more ET and ultimately grain yields (Tables 11 and 15) because tillage practices regulate soil texture, disturbing capillarity and thus ET. Therefore, in Season II, the S1 crop had higher ET and thus lower soil moisture stored (450.3 mm) by 133 DAS than S2 and S3 (tables 15 and 13). It resulted into more dry matter production (4.26 t ha^{-1} ; Table 7), but similar grain yield (2.03 t ha^{-1} ; Table 11) as compared to the other sowing times. Therefore, the ultimate grain yield of chickpea is influenced by a multiplicity of independent and co-independent environmental factors that make it difficult to isolate or distinguish on factor/attribute as being a sole contributor to a certain event and/or production.

It can be concluded that to ensure optimal growth and yield of *kabuli* chickpea, sowing time must be synchronized with soil moisture availability or rainfall. To avoid the effects of erratic rainfall as observed in Season I (that affected S1 and S2) a supplementary irrigation of 90 – 105 mm water should be required to ensure sufficient soil moisture storage for proper germination, establishment and growth up to 35 DAS. In Season I, it was observed that the rainfall received within the first 35 DAS of chickpea growth (53.4 mm for S1, 33.3 for S2 and 33.3 for S3) was poorly distributed and therefore not enough for optimal and successful chickpea establishment and growth (Table 2). Thus, the requirement of between 11.2 to 56.2 mm (about 38.8 mm mean) irrigation water (Figs. 13, 14, 15 and 16) should be enough to supplement equivalent rains and therefore recharge soil moisture for purposes of enhancing water uptake (i.e. split twice at an interval of fifteen days). However, water application may be needed intermittently over the initial growing period.

One way of increasing yield of chickpea in East Africa is to advance the sowing date so that the crop will have much better moisture availability and distribution for early growth and production of larger biomass (Kumar and Abbo, 2001). This can be possible at Naivasha with application of irrigation only as indicated above.

5.6 Evapotranspiration-Yield relationship under varying tillage and sowing dates

Seasonal evapotranspiration (ET) under tillage treatments showed no significant differences (Table 15). Strip tillage practice, however, resulted relatively lower ET (127.5 – 272.1 mm) compared to other tillage methods in both seasons. These findings collaborates those of Shaffiq *et al.* (1994) in clay loam soils who reported that cumulative intake and intake rates were significantly higher in zero tillage treatments as the cover in them reduced the incidence of crust conditions. Connolly *et al.* (1998) later reported that appropriate tillage and cover management are required to maintain high infiltration rates. Therefore, while strip tillage permitted relatively higher water intake rates than other tillage practices, thus avoiding crust conditions and consequently soil surface sealing (Connolly *et al.*, 1998), it also hindered higher ET as its soils were least disturbed to permit higher ET losses especially in the upper soil layers.

The narrow range of ET in Season II (Table 15) was due to the more water received (278 mm) by crop and the combined effects of tillage and sowing date treatments (which modified available soil water storage), as compared to lower amounts of water received in Season I (210 mm). Siddique *et al.* (2001) earlier noted that there was no difference in the total ET among grain legumes under low rainfall conditions and no variation in soil moisture among species. Therefore, low moisture availability is likely to confound imposed treatment effects, which would largely remain insignificant and unnoticeable.

Seasonal crop evapotranspiration (ET) increased with maturity of chickpea crop irrespective of tillage method and sowing time treatments. Seasonal ET by 133 DAS was higher under conventional tillage (CT) and double tillage (DT) methods in Season I. This implies that both CT and DT treatments lost more moisture than in the case of ST and FT in this season, which therefore proved the latter tillage practices to be better soil moisture conservation practices. Mayande (1995) noted that the role of proper tillage in drylands is to provide a suitable environment for seed germination, root growth, weed control, soil erosion control and moisture control and reducing moisture stress. Therefore, ST and FT should be encouraged in Naivasha to enhance moisture conservation and thus increase crop yields.

The rate of increase in chickpea biomass per increase in ET was approximately 17.5 kg ha-mm⁻¹ water used (or 17.5 kg ha-m⁻³ of water use), as given by the linear functions for both seasons (Figs 13 to 16). This was higher than 9.6 kg ha-mm⁻¹ reported by Brick *et al.* (1998) and 10.6 kg ha-mm⁻¹ of water use reported by Nielson (2001), but close to 15.6 kg ha-mm⁻¹ reported from Australia (PIRSA, 2000). The regression correlation coefficients were high at approximately 0.89 for both seasons. Oweis *et al.* (2003) noted that yield versus seasonal evapotranspiration also plots as a straight line relationship. They found the linear relationship to be the most appropriate for winter chickpea-early sown (late November) and grown in rotation with wheat in the Mediterranean region. In the current study the resulting best fit linear equations for biomass yields gave values of ET at zero yields of about 100 mm as compared to that of Oweis *et al.* (2003), which was 73 mm. Correlation coefficients for the grain and biomass yield (0.59 and 0.62, respectively) could, however, be improved when regression analysis was performed on the data of each sowing date separately. With respect to grain yield, however, Kang *et al.* (2002) reported that a maximum ET did not result in the highest yield.

The higher variation in DM production per unit increase in water use at higher ET values for second season was probably caused by tillage variables, which would have modified soil moisture storage. These treatments varied the available water content, which consequently influenced the DM production, at later stages of crop growth that matured under reducing moisture availability.

Linear regressions (Figs 13 to 16) relating ET-biomass relationships reveal that the yield of kabuli chickpea related well with the seasonal ET and that between 100 - 110 mm of ET was required before actual biomass production. This could be explained by the fact that readings were first taken 35 DAS and that most of the lost water was due to the evaporative demand during the early stages of crop growth. The biomass yield appears to increase with ET meaning that. The minimum water requirement for crop growth and establishment up to 35 DAS was observed to range between 90 – 110 mm (Figs 13 to 16). This concurs with the earlier findings of Oweis *et al.* (1999).

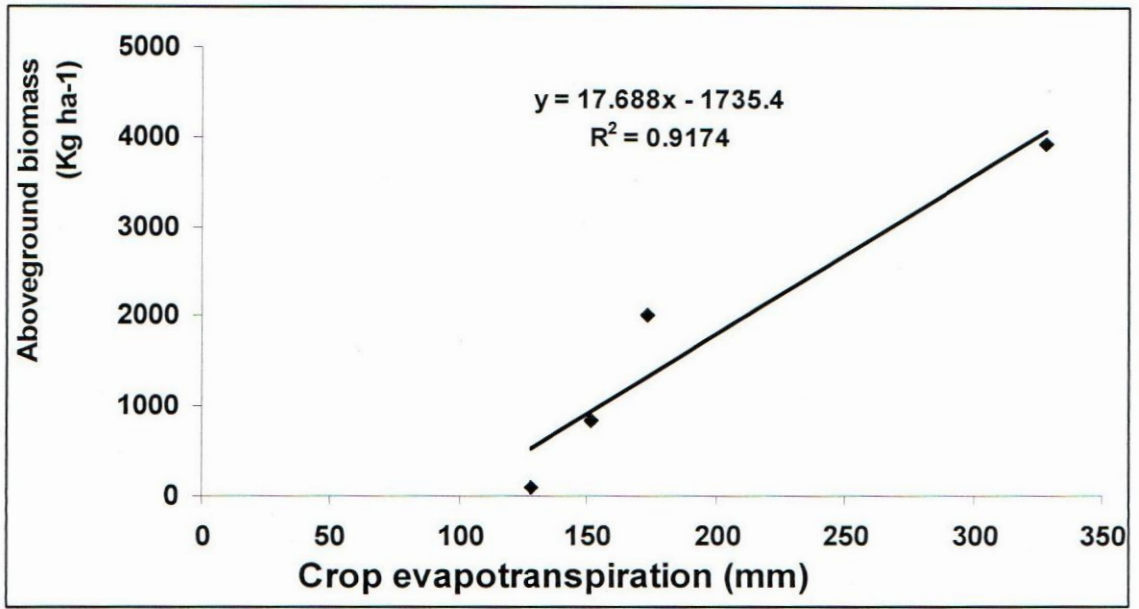

Figure 13 Crop evapotranspiration-biomass yield relationship for *kabuli* chickpea under varying tillage methods in Season I

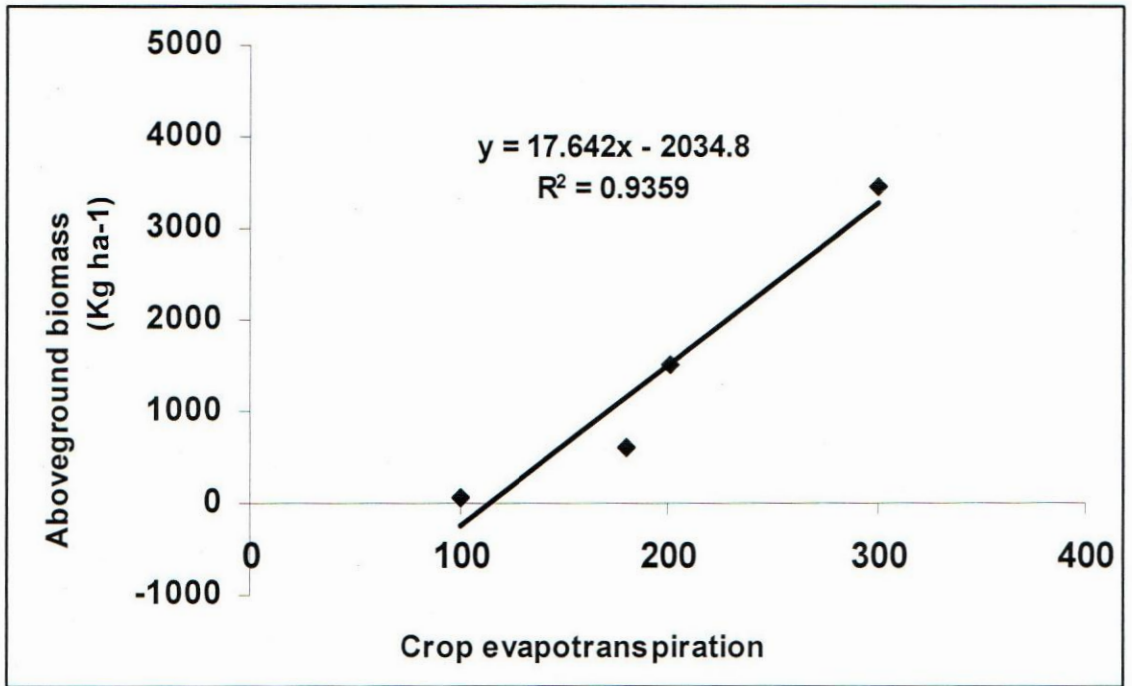

Figure 14 Crop evapotranspiration-biomass yield relationship for *kabuli* chickpea under varying tillage methods in Season II

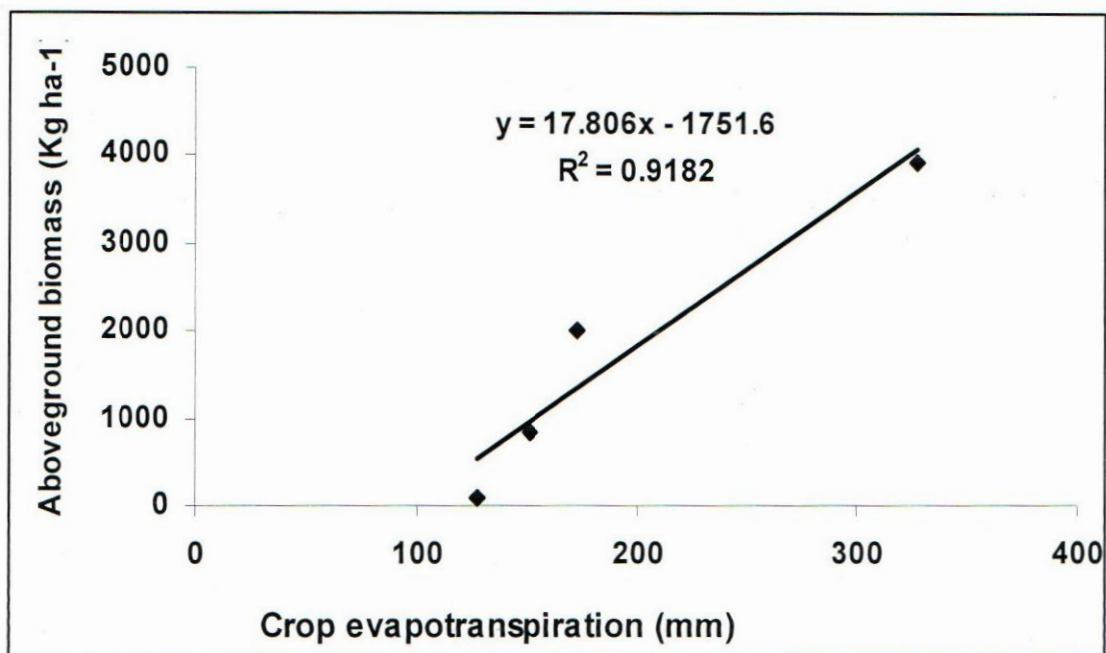

Figure 15 Crop evapotranspiration-biomass yield relationship for *kabuli* chickpea under varying sowing times in Season I

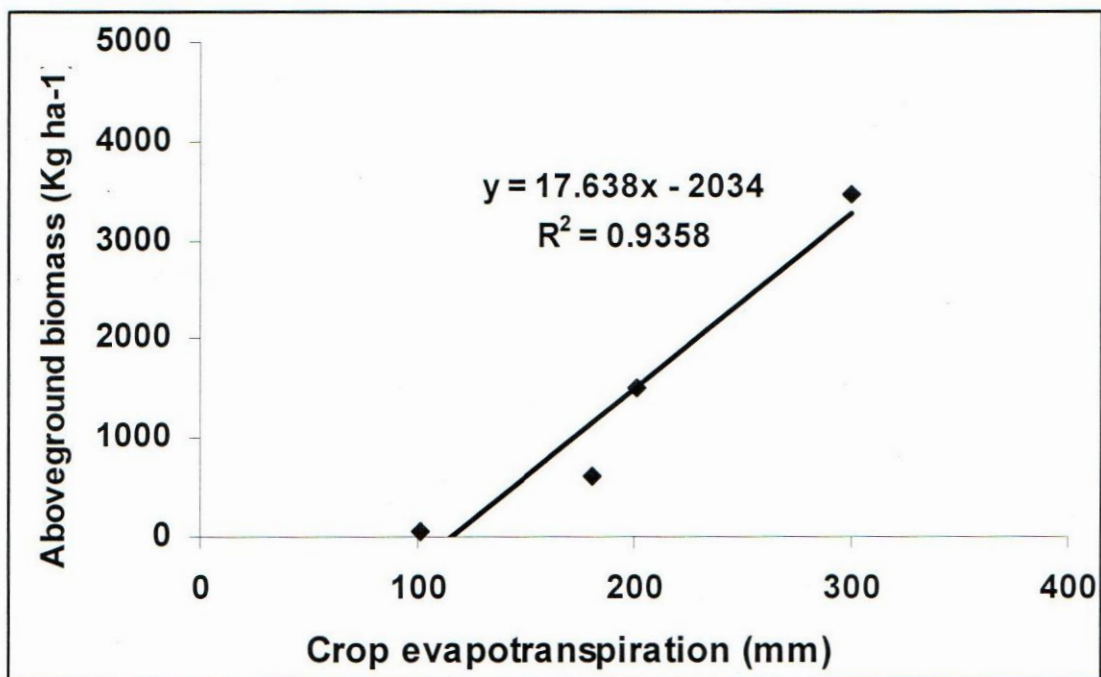

Figure 16 Crop evapotranspiration-biomass yield relationship for *kabuli* chickpea under varying sowing times in Season II

Nielson (2001) found yield increase with water used by chickpea to be $10.6 \text{ kg ha-mm}^{-1}$. He reported that grain yields ranged from 600 to 3500 kg ha^{-1} for 220 to 420 mm water use. In the present study the linear functions show that yield continues to increase with seasonal evapotranspiration (ET). This implies that with more volumes of water, the crop is likely to yield more under the prevailing weather conditions where linear functions are sufficient to explain the relationships. This scenario was observed in Season I where the chickpea exhibited the indeterminate growth habit occasioned by the rains that came late in the season.

5.7 Tillage method and sowing time effects on water use efficiency by chickpea

The WUE of chickpea on total aboveground biomass basis (WUE_b) increased with crop maturity to a range of 9.76 to 13.3 kg DM ha-mm^{-1} in Season I and 10.08 to 16.07 kg DM ha-mm^{-1} in Season II (Fig 21). Conventional tillage (CT) in Season I had a significantly lower ($P < 0.05$) WUE_b than all the other tillage methods (Table 16). This was attributed to loss of soil moisture by ET due to its poor ability to permit infiltration and thereby conserved less soil moisture. Therefore, CT availed low moisture for uptake, growth and aboveground DM production by chickpeas (Tables 7, 10 and 13). Nielson (2001) found yield increase with water used by chickpea to be $10.6 \text{ kg DM ha-mm}^{-1}$. Grain yields ranged from 600 to 3500 kg ha^{-1} with 220 to 420 mm of water use. The results of the current study were within these limits and ranged from 1400 to 2500 kg ha^{-1} with 280 to 320 mm of water use.

5.8 Effects of tillage method and sowing time on moisture use rate

The moisture use rate in Season II decreased with time of sowing which was a similar trend for grain yields (Tables and 18). This was unlike Season I where there were rain incidences later in the season. Working on late sown wheat, Kibe and Singh (2002) noted that increased soil moisture use rate at higher soil moisture availability was probably due to the enhanced growth leading to higher leaf area indices and stomatal apertures opening for longer periods. This means that under conducive environments MUR can give an indication on potential grain yield of *kabuli* chickpea as was observed in this study.

CHAPTER SIX

6.0 CONCLUSIONS AND RECOMMENDATIONS

6.1 CONCLUSIONS

1. In both seasons under the Naivasha conditions, strip tillage was the best practice that availed soil moisture to the *kabuli* chickpea for productive purposes while conventional tillage was the least productive tillage method.
2. Early sowing times in both seasons were more conducive for chickpea production save for the sowing time whose crop benefited from incidental rainfall in the course of growth.
3. There were no significant interaction effects between tillage methods and sowing times on the overall crop growth and development except for the evapotranspiration in Season II. The factors under study therefore had independent effects on crop production.
4. Infiltration rates were independent of tillage methods and sowing times under the Naivasha conditions in both seasons.

6.2 RECOMMENDATIONS

The proposed future line of work includes the following:

1. Development of a model for chickpea yield based on the growth and yield parameters.
2. Effects of limited irrigation on chickpea performance under varying sowing times.
3. Estimation and validation of evapotranspiration using different methods of measurement for different AEZ in Kenya.
4. Comparison of the different methods of measurement of infiltration rates in view of finding the best suited for different soil conditions.

REFERENCES

- ACA.2004.** *Agriculture Crops Alternatives*. Saskatchewan Interactive
- Afolayan S. O., Babalola O., and Igbeka J. C. 2004.** Effect of tillage on soil physical properties, growth and yield of amaranth. *Afri. Crop Sci. J.* 12(2): 141-151.
- Al-Qinna, M. I. and Abbu-Awwad. 1998.** Infiltration rate measurements in arid soils with surface crust. *Irrigation Science*. 18: 83-89. Springer-verlag.
- Allmaras R. R., Betz C. L., Copeland S. M. and Randall G. W. 1998.** Least limiting water range: traffic and long-term tillage influences in a Webster soil. *Soil Sci. Soc.Am. J.* 62(5): 1384-1393.
- Anderson R. L, Aiken R. M, Benjamin J. G, Bowman R. A., Nielson DC and Vigil MF. 1999. Alternative Crop Rotations for the Central Great Plains. *J. Prod. Agric.*12: 95-99.
- Anwar, M. R., McKenzie, B. A. and Hill, G. D. 2002.** Water extraction patterns and water use efficiency of chickpea (*Cicer arietinum L.*) cultivars in Canterbury. *Agron. J.* (New Zealand). 30.109-120.
- Aparicio N, Villegas D, Casadesus J, Araus J. L. and Royo C. 2000.** Spectral vegetation indices as nondestructive tools in determining durum wheat yield. *Agron. J.* 92(2): 83-91.
- Bejiga G, Tullu A, Tsegaye S, Eshete M and Anbessa Y. 1997.** Soil surface drainage and yield of chickpea grown on vertisols in Ethiopia. *Afr. Crop Sci. J.* 5(1): 23-29.
- Berliner P. R., Droppelman K. J., Ephrath J. E. and Lehman J. 2000.** Water use efficiency and uptake patterns in a runoff agroforestry system in an arid environment. *Agroforestry Systems*, 49:223-243.
- Birch C.R., Dalal R. C., Doughton J. A., and Horn C. P. 1996.** Sowing time and Tillage practice affect chickpea yield and nitrogen fixation. I. Dry matter accumulation and grain yield. *Aust. J. Expt. Agric.* 36(6): 695-700.
- Bordovsky J. P., Lyle W. M., and Keeling J. W. 1994.** Crop rotation and rotation effects on soil water and cotton yield. *Agron. J.* 86(1): 1-6.
- Bouyoucos, B.J., 1951.** A calibration of the Hydrometer Method for mechanical Analysis of Soils. *Agron.J.*43:434-438.
- Cessman, K. G. 2001.** Crop Science Research to Ensure Food Security. In, Nesberger *et al.* (eds.). *Crop Science: Progress and Prospects*, pp.33-51.

- Chevalier P. M., Kabakii H. and Papendick R. I. 1993.** Impact of tillage and residuemanagement on dryland spring wheat development. *Soil and Tillage Research*. 26:127-137.
- Connolly, R. D., Freebairn, D. M., and Bell, M. J. 1998.** Changes in soil infiltration associated with leys in south-eastern Queensland. *Australian J. Soil Res.* 36(6). 1051-1072.
- Dalal, R. C., Strong, W. M., Doughton, J. A., Weston, E. J., McNamara, G. T., and Cooper, J. E. 1997.** Sustaining productivity of a Vertisol at Warra, Queensland, with fertilizers, no-tillage or legumes. 4. Nitrogen fixation, water use and yield of chickpea. *Aust Expt. Agric.* 37(6): 667-676.
- Dalal, R. C., Strong, W. M., Weston, E. J., Wildermuth, G. B., Lehane, K. J., King, A. J., and Holmes, C. J. 1998.** Sustaining productivity of a Vertisol at Warra, Queensland, with fertilizers, no-tillage or legumes. 4. Wheat yields, nitrogen benefits and water use efficiency of chickpea-wheat rotation. *Aust.J. Expt. Agric.* 37(6): 667-676.
- Dregne, H. E. 1982.** Dryland Soil Resources. Science and Technology Agriculture Report, *Agency for International Development*, Washington.
- Eghball, B and Maranville J. W. 1993.** Root development and nitrogen influx of Corn geno type's growth under combined drought and nitrogen stresses. *Agron. J.* 85(2):147-152.
- El-Swaify, S. A., Pathak, P., Rego, T. J., and Singh S. 1985.** Soil management for optimized productivity under rainfed conditions in the semi-arid tropics. *Adv. Soil Sci.*, 1:1-64.
- Food and Agriculture Organization of the United Nations, FAO. 1974.** Improving productivity in low rainfall areas. *Report to the Committee on Agriculture*. COAG/74/4Rev.I.FAO.Rome.
- Food and Agriculture Organization of the United Nations, FAO, 1998.** Crop evaporation: guidelines for computing crop water requirements, FAO Irrigation and Drainage Paper 56.
- Fietelson, E. 2000.** The upcoming challenge: Transboundary management of the hydraulic cycle. *Water, Air and Soil Pollut.* 123(1-4):533-549.
- Gaze, S. R., Simmonds, L. P., Brouwer, J., and Bouma, J. 1997.** Measurement of

surface redistribution of rainfall and modeling its effects.

Greacen, E.L. 1981. Soil Water Assessment by Neutron Method. CSIRO. East Melbourne, Victoria, Australia.

GoK, Government of Kenya, Ministry of Economic Planning and National Development, (1999): *Census Report for Kenya*.

Gregory, P. J. 1988. Plant and management practices affecting the water use efficiency of dryland crops, pp. 171-175. *In: Proceedings of International Conference on Dryland Farming, Armarillo, Bushland, Armarillo, Bushland, Wiley and Sons, NY.*

Guto, S. N. 1997. Effects of chickpea and common beans on wheat performance and soil fertility in a legume-wheat sequence. MSc Thesis. *Department of Agronomy, Egerton University, Njoro, Kenya.*

Hardman, L. L., Oelke, E. A., Kaminskil, A. R. and Dolli, J. D. (1990). Chickpea (garbanzo bean). University of Wisconsin – Madison, WI.

Harris H., Oweis, T., Pala, M., and Zhang H. 2000. Water use and water use efficiency of chickpea and lentil in a Mediterranean environment. *Aust. J. Agric.Res.* 51: 295-304.

Hedge, B. R. 1995. Improving water use efficiency under dryland conditions, pp. 177-175. *In Sustainable Development of Dryland Agriculture in India, R.P. Singh (Ed.), Scientific Publishers, Jodhpur.*

International Chickpea and Pigeonpea Newsletter, 1994. ICPN, No. 1.

International Centre for Research in Semi-Arid Tropics, ICRISAT. 1987. Adaptation of Chickpea and Pigeonpea to Abiotic Stresses. *Proceedings of the Consultants' Workshop held at ICRISAT Centre, India, 19-21 December 1984.* Patancheru, Andhra Pradesh. 502 324, India.

International Centre for Research in Semi-Arid Tropics, ICRISAT. 1993. Legumes Program. *International Crops Research Institute for Semi-Arid Tropic* , p163.

Jaetzold, R., and Schmidt H., 1983. Farm Management Handbook of Kenya, Volume II, Part B: Natural Conditions and Farm Management Information, Central Kenya (Rift Valley and Central Provinces). 121-151:379-404.

Jordan, W.R.; Sinclair, T. R. and Taylor, H. M., 1990. *Limitations to Efficient Water Use in Crop Production.*

Kang, S., Zang, L., Liang, Y., and Cai, H., 2001. Effect of limited irrigation on yield and water use efficiency of winter wheat on the Loess Plateau of China, pp.105-116. *In* McVicar, T.R., Li Rui, Walker, J., Fitzpatrick, R.W., and Liu Changming (ed). Regional water and soil assessment for managing sustainable agriculture in China and Australia, ACIAR monograph No. 84.

Keatinge, J.D.H. and Cooper, P. J. M., 1983. Kabuli chickpea as a winter-sown crop in northern Syria: moisture relations and crop productivity. *J. Agric. Sci. (Cambridge)* 100, pp. 100 667–680.

Khanna-Chopra, R. and Sinha, S. K. (1987). Chickpea: Physiological aspects of growth and yield. *In* . Saxena and K. B. Singh (Eds.), “The Chickpea”, pp. 163 – 190. CAB International, Wallington, UK.

Kibe, A. M. and Singh (2002). Influence of irrigation, nitrogen and zinc on productivity and water use by late sown whet (*Triticum aestivum*). *Ind. J.Agron.* 48(3):186 – 1991.

Kostrinski, J. (1974). “Problems in Chickpea Cultivation and Grain Crop Rotations in Israel”, Special Publication No. 34, Agricultural Research Organization. Bet-Dagan, Israel

Kumar, J., Sethi, S. C., Johansen, C., Kelly, T. G., Rahaman, M. M. and van Reheman A. A. (1996). Potential of short-duration chickpea varieties. *Ind. J. Dryland Agric. Res.* 11:28 – 32.

Kumar, J. (2000). Pulses: Towards a quantitative leap. *In* “Hindu Survey of Indian Agriculture”, pp. 49-52.

Kumar, J., and Abbo, S. (2001). *Adv. Agron.*, Volume 2, Academic Press.

Le Bissonnais, Y. and Singer, M. J. (1992). Crusting, runoff and erosion response to soil water content and successive rainfalls. *Soil Sci. Soc. Am. J.* 56: 1898 98 – 1903.

Marx, G.A. (1985). The pea genome: A source of immense variation. *In* P. D. Hebblethwaite, M. C., T.C.K. Dawkins (Eds.). “The Pea Crop: A Basis for Improvement”, pp.45 – 54. Butterworths, London.

Mayande, V. M. 1995. Tillage in Drylands: Principles and Practices, pp. 217-227. R.P. Singh (Ed). Sustainable Development of Dryland Agriculture in India. Scientific Publishers, Jodhpur

- Michael, A. M. 1997.** IRRIGATION: Theory and Practice. Vikas Publishing House PVT Ltd.
- Miller, M. N., McConkey B. G., Clayton G. W., Brandt S. A., Staricka J. A., Johnson A. M., Lafond G. P., Schatz B. G., Baltensperger D. D. and Neill K. E. 2002.** Pulse crop adaptation in the Northern Great Plains. *Agron. J.* 94(2): 261-272.
- Mwendera E. J. and Feyen J. 1994.** Effects of tillage and evaporative demand on the drying characteristics of a silt-loam: an experimental study. *Soil Tillage Res.* 32(1): 61-69.
- Mwendera E. J and Feyen J. 1997.** Tillage and evaporativity effects on the drying characteristics of a silty-loam: evaporation prediction models. *Soil Tillage Res.* 41(1/2): 127-140.
- National Animal Husbandry Research Centre, NAHRC. 2003,** *KARI Annual Report.*
- Nielson DC, Anderson RL, Aiken R. M, Benjamin J. G and Bowman R. A, 1999.** Winter wheat and proso millet yield reduction due to sunflower in rotation. *J. Prod. Agric.* 12:193-197.
- Nielson, D. C., 2001.** Production functions for chickpea, field pea, and lentil in Central great Plains. *Agron. J.* 93(3): 563-569.
- Oram, P. 1980.** What are the world's resources and constraints for dryland agriculture? p.17-78. *In* International Congress on Dryland Farming. South Australian Department of Agriculture, Adelaide, Australia.
- Oweis, T., Hachum, A., 2003.** Improving water productivity in the dry areas of West Asia and North Africa. In: Kijne, W.J., Barker, R., Molden, D. (Eds.), *Water Productivity in Agriculture: Limits and Opportunities for Improvement.* CABI Publishing, Wallingford, UK, pp. 179–197.
- Oweis, T., Hachum, A., Kijne, J., 1999.** Water harvesting and supplemental irrigation for improved water use efficiency in dry areas. SWIM Paper No. 7, System-Wide Initiative on Water Management. International Water Management Institute, IWMI, Colombo, Sri Lanka.
- Oweis, T., Hachum, A., Pala, M. 2003.** Water use efficiency of winter-sown chickpea under supplemental irrigation in a Mediterranean environment. *Agric.l water manage. J.l* 73: 123-135

- Parr J. F. Singh R. P. and Stewart B. A. 1990.** *Advances in Soil Science: Dryland Agriculture*. Vol. 13. Springer-Verlag, New York.
- Reeves M and Miller E.E.1975.** Estimating infiltration for erratic rainfall. *Water Resou. Res.* 11:102-110.
- Ryan, J. G. (1997).** A global perspective on pigeon pea and chickpea sustainable production systems: Present status and future potential. In A. N. Asthana and Masood Ali (Eds.). "Recent Advances in Pulses Research", pp. 1 – 31. *Ind. Soc. Pulses Res.* (ISPR), Kanpur, India.
- Salih, A. A., Babikir, H. M., and Ali, S. A. M. 1998.** Preliminary observations on effects of tillage systems on soil physical properties, cotton root growth and yield at Gezira Scheme, Sudan. *Soil Tillage Res.*, 46(3/4): 187-191.
- Saxena, M. C. 1976.** Recent advances in chickpea agronomy. Pages 89-96 In: International Workshop in Chickpea Improvement, 28 February-2 March, 1979, Hyderabad, India. Patancheru, A.P. 502 324, India, ICRISAT.
- Saxena, M.C., 1984.** Agronomic studies on winter chickpeas pp. 123–137. In: Saxena, M.C., Singh, K.B. (Eds.), Proceedings of the Workshop on Ascochyta Blight and Winter Sowing of Chickpeas, ICARDA, 4–7 May 1981, Aleppo, Syria,.
- Saxena, N. P. 1984.** The Chickpea. Pages 419-452, In: Physiology of Field Crops (Goldworthy and Fisher, eds.), Chichester, Sussex, UK: Wiley.
- Saxena, M.C., 1987.** Agronomy of Chickpea. In: Saxena, M.C., Singh, K.B. (Eds.), The Chickpea. C.A.B. International, Wallingford, UK, pp. 207–232.
- Schultz, D. E. 1986.** Carbon dioxide and water vapor exchange in response to drought in the atmosphere and in the soil. *Ann. Rev. Plant Physiol.* 37:247-274.
- Shafiq, M., Haasan A., Ahamad S., and Akhtar, M. S. 1994.** Water intake as influenced by tillage in rainfed areas of Punjab (Pakistan). *J.Soil Water Conserv.* 49(3). 302 - 305.
- Sharma, A. N., Paraya, R. P., and Patel, M. P. 1989.** Effect of sowing dates and row spacings on leaf area, leaf efficiency, harvest index and yield of mungbean genotypes during summer season. *National Symposium on New Frontiers in Pulse Research and Development*, Kanpur, India, pp.85.

- Shedrake and Saxena, N. P. 1979.** The growth and development of chickpea under progressive moisture stress. *In Stress Physiology in Crop Plants*. Eds H. Mussel and R.C. Staples, pp 465-486. *John Wiley and Sons*, Chichester.
- Shelton Pandua, Sundara Sarma, K. S., Subba Rao, Y. V. and Chandrashekara, H., (2002).** Root zone soil water balance in a watershed differing in soil characteristics and land use conditions. *Journal of Water Management*. 12(1).1-13.
- Siddique, K. H. M.; Loss, S. P. Pritchard D. L.; Regan, K. L.; Tennant, D.; Jettner, R. L. and Wilkinson, D. 1998.** Adaptation of lentil (*Lens culinaris* Medik.) to Mediterranean-type environments: effect of time of sowing on growth, yield, and water use. *Australian Journal of Agricultural Research*.49: 613-626.
- Siddique, K. H. M., Regan, K. L., Tennant , D., and Thomson, B. D. 2001.** Water use and water use efficiency of cool season grain legumes in low rainfall Mediterranean environments. *Eur. J. Agron*. 15(4): 267-280.
- Singh, G. 1984.** Water use in chickpea as affected by irrigation scheduling in semi-arid region. *Trans. Indian Soc. Desert Technol*. 9:58-61.
- Singh R. P. 1995.** Sustainable Development of Sustainable Agriculture in India. *Scientific Publishers*, Jodhpur, India.
- Stanhill, G. 1966.** Water Use Efficiency. *Adv. Agron*. 39: 53-85.
- Steiner J. L, Day J. C., Papendik R. I., Meyer R. E. and Bertrand A. R. 1988.** *Adv. Soil Sci.*, Vol. 8. Springer-Verlag, New York.
- Soltani A., Khoorie F. R., Ghassemi G. K., and Moghaddan M. 2001.** A simulation study of chickpea response to limited irrigation in a semiarid environment. *Agri. Water Manage*. 49(3):225-237.
- Sow, A., Hossner, L., Unger, P. W., and Stewart, B. 1996.** Effects of furrow diking and tillage on water storage, plant water use efficiency and yield of sorghum. *Afr. Crop Sci. J*. 4 (4): 443-440.
- Subbarao, G. V., Johansen, C., Slinkard, A. E., Nageswara Rao, R. C., Saxena, N. P. and Chauhan, Y. S. (1995).** Strategies for improving drought resistance in grain legumes. *Critic. Rev. Plant Sci*. 14:469 – 523.
- Thomas B. D. and Siddique, K. H. M. 1997.** Grain legume species in low rainfall Mediterranean-type environments. II. Canopy development, radiation interception, and

dry matter production. *Field Crops Research*. 54:189-199.

Thomas F. S., and Hammer G. L. 1995. Growth and yield response of barley and chickpea to water stress under three environments in Southeastern Queensland. II. Root growth and soil water extraction pattern. *Aust. J. Agric. Res.* 46:35-48.

Upadhyaya H. D. Bramel P. J, and Sube Singh. 2001. Development of a chickpea core subset using geographic distribution and quantitative traits. *Crop Sci. J.* 41(1). 206-210.

Wilhelm, W. W., Ruwe, K., and Schlemmer, M.R. 2000. Comparison of three leaf area index meters in a corn canopy. *Crop Sci.* 40:1179-1183

Viets, F. G. 1962. Fertilizers and efficient use of water. *Adv. Agron.* 14:223-264.

APPENDIX 1: Relative humidity (%), temperature ($^{\circ}\text{C}$) and gust (km h^{-1})

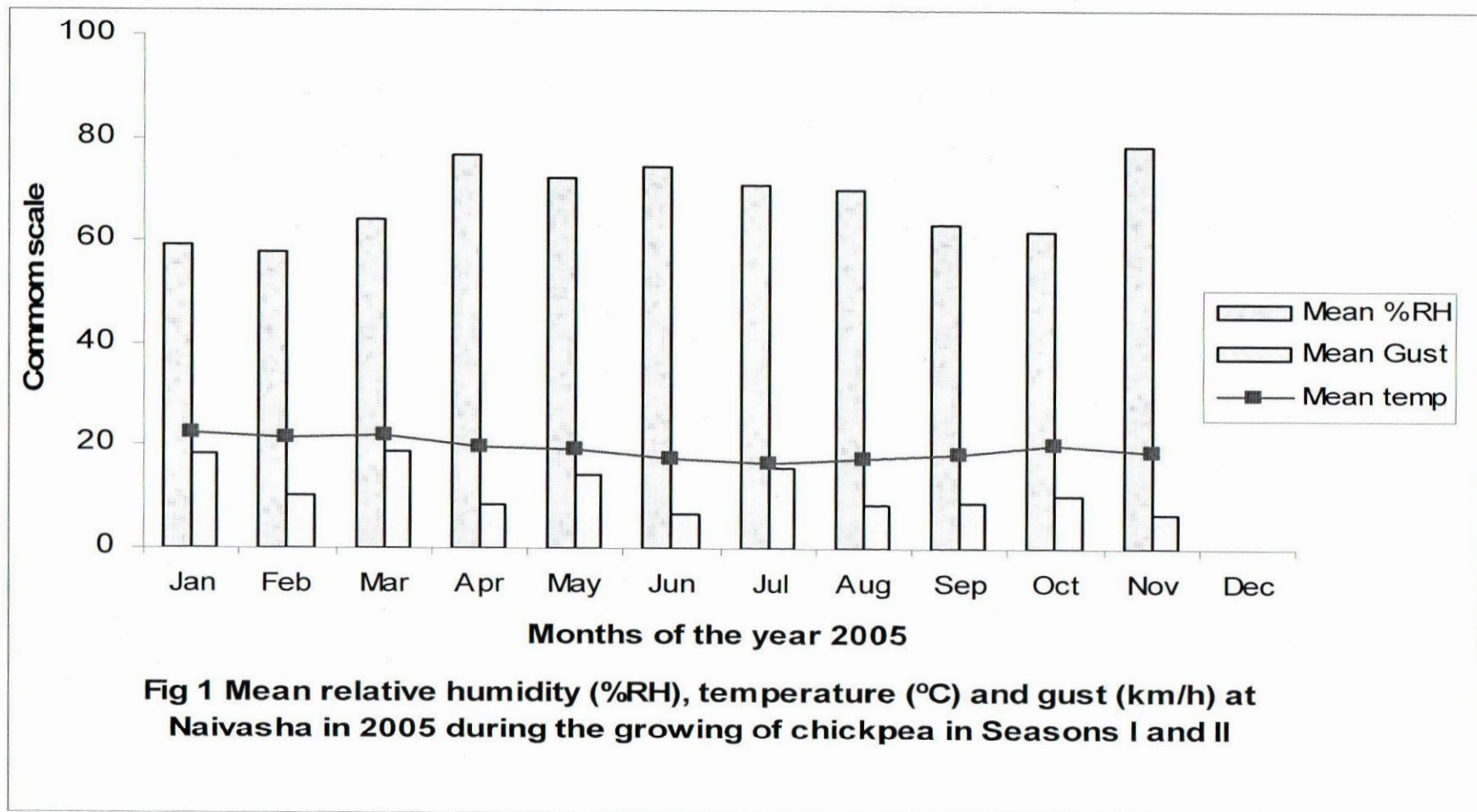

APPENDIX II: Rainfall (mm) distribution at KARI-Naivasha in 2005

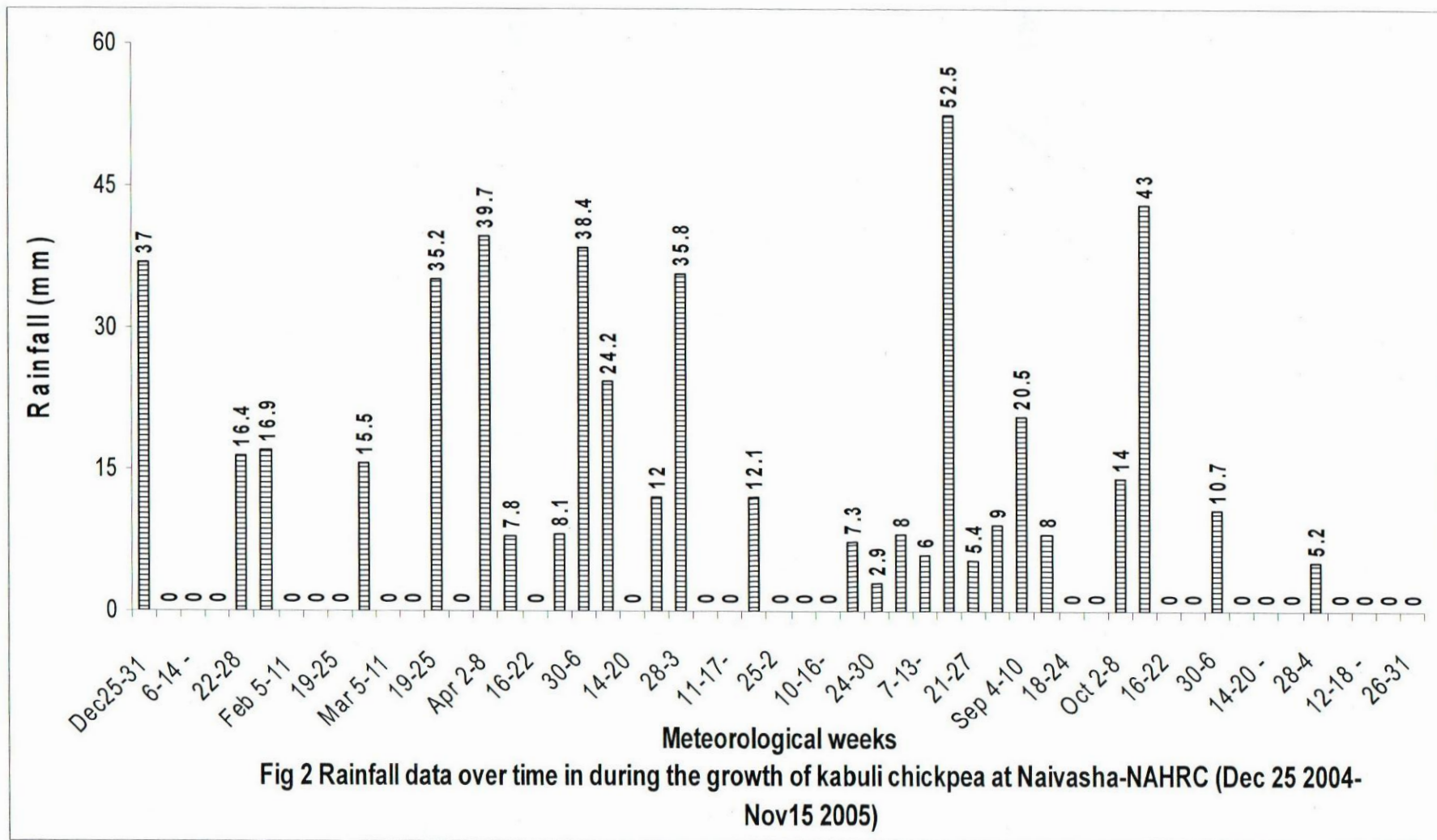

APPENDIX III: Effects of tillage methods on plant height of kabuli chickpea grown at KARI-Naivasha in Season I and II

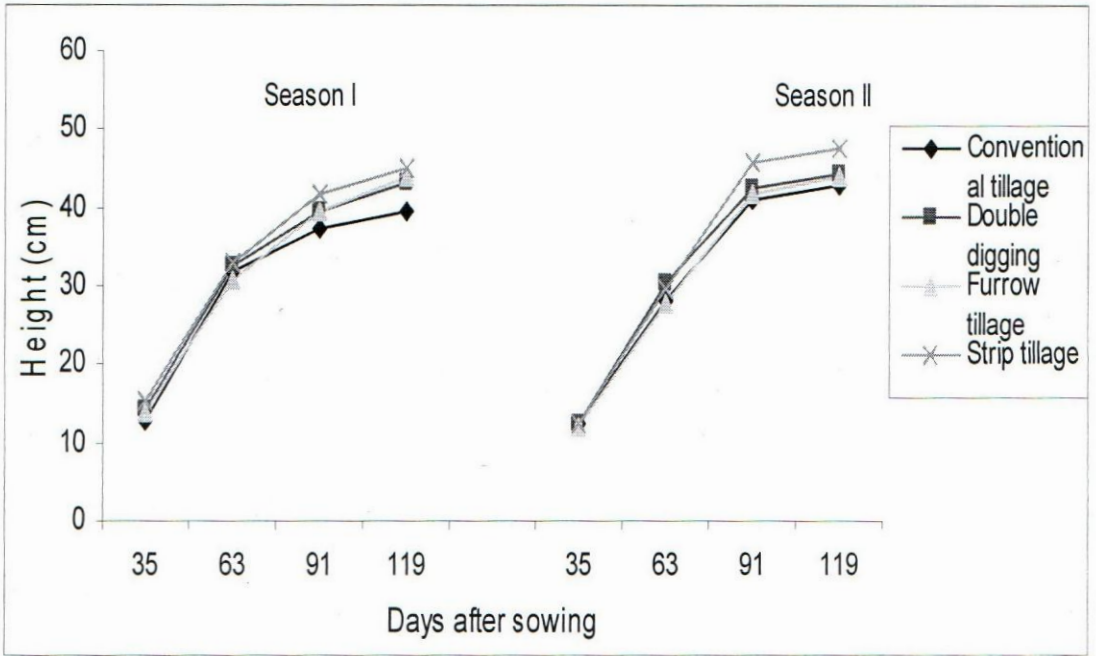

APPENDIX IV: Effects of sowing times on plant height of kabuli chickpea grown at KARI-Naivasha in Season I and II



APPENDIX V: Effects of tillage methods on leaf area index of kabuli chickpea grown at KARI-Naivasha in Season I and II

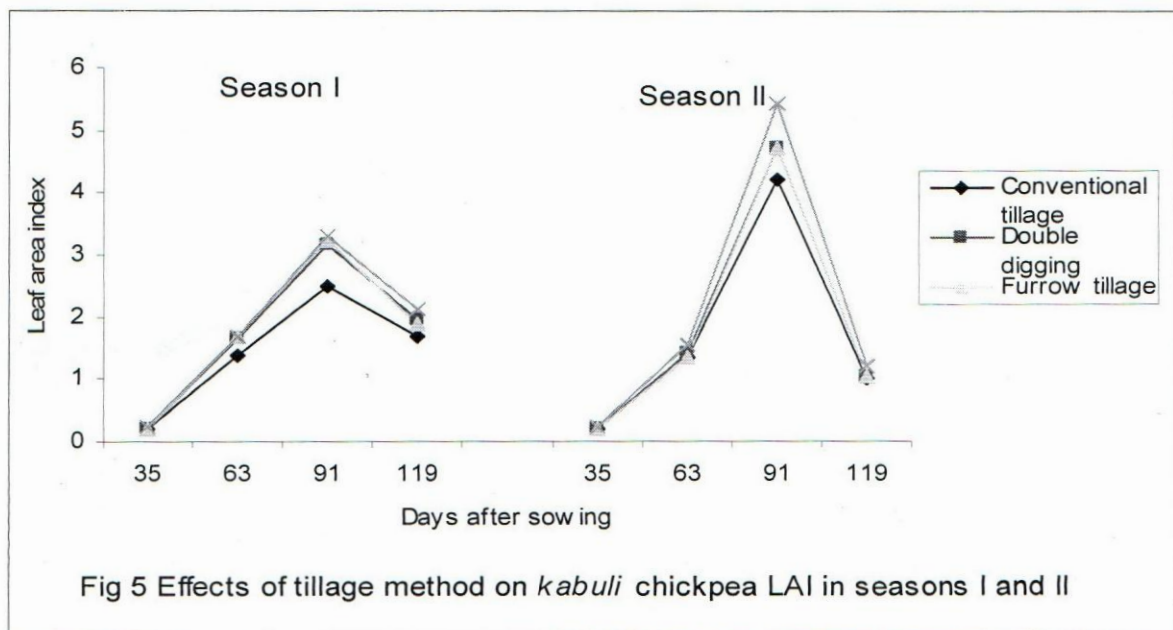

APPENDIX VI: Effects of sowing time on leaf area index grown of kabuli chickpea grown at KARI-Naivasha in Season I and II

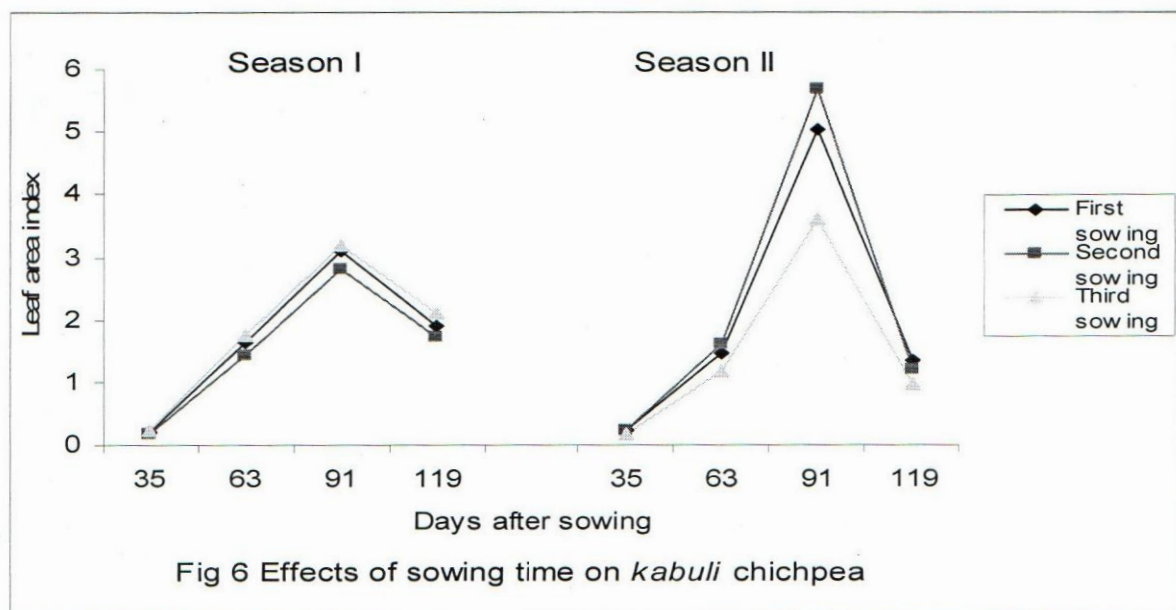

APPENDIX VII: Effects of tillage methods on the total number of branches per plant of *kabuli* chickpea grown at KARI-Naivasha in Season I and II

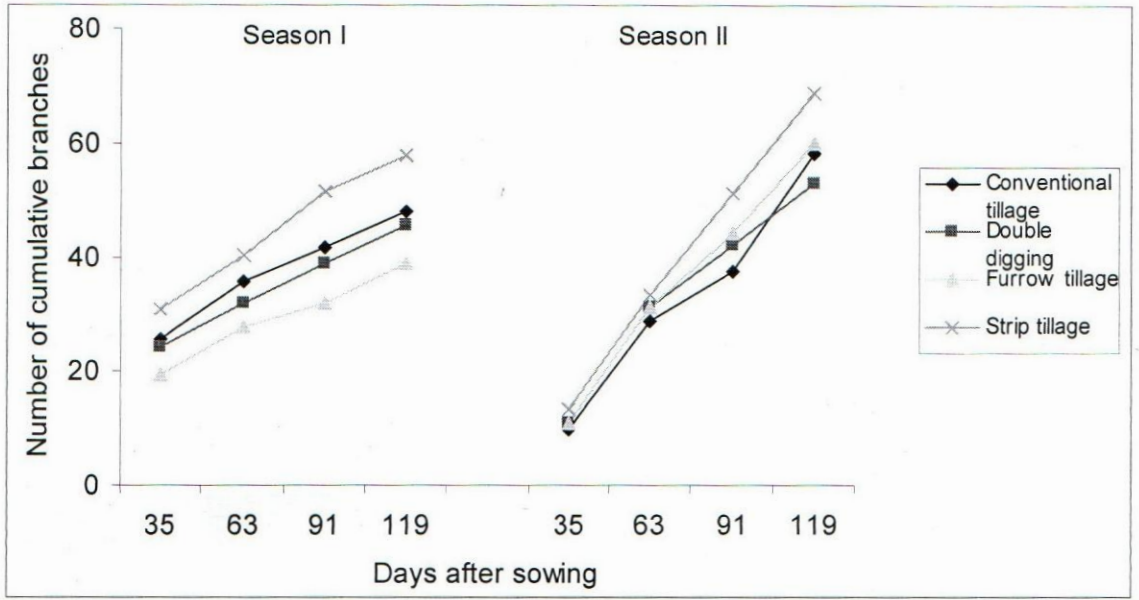

APPENDIX VIII: Effects of sowing times on the total number of branches per plant of *kabuli* chickpea grown at Naivasha in Season I and II

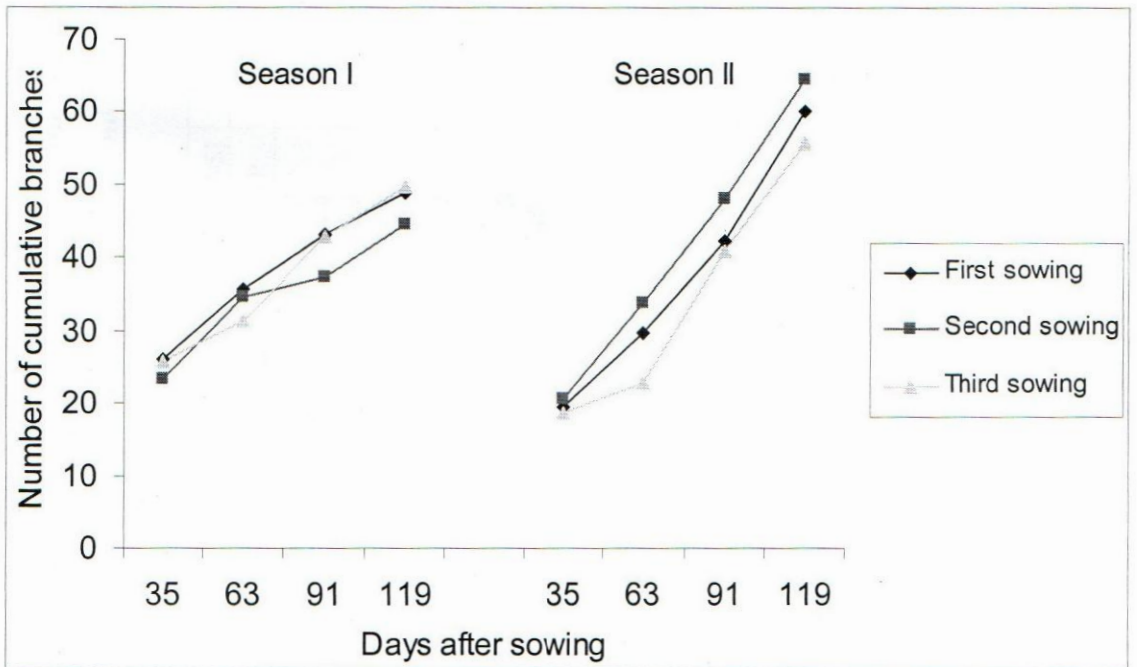

APPENDIX IX: Extracts from ANOVA tables showing means of select growth and yield parameters for *kabuli* chickpea grown at KARI Naivasha in Season I and II under different tillage methods and sowing times

Table (a)

Treatment	Plant height, cm, (119 DAS)		LAI (91 DAS)		Branches/plant (119DAS)		DM biomass (133DAS)	
	Season I	Season II	Season I	Season II	Season I	Season II	Season I	Season II
Conventional tillage	39.7b	42.8	2.50b	4.22b	48.2b	58.4ab	3242.1b	3208.9b
Double tillage	43.0c	44.4	3.16a	4.71ab	45.7ab	53.1b	3994.9a	3073b
Furrow tillage	43.8c	43.9	3.23a	4.71ab	39.1c	59.9ab	4229.0a	3035.8b
Strip tillage	45.1a	47.7	3.31a	5.44a	57.9a	68.8a	4231.3a	4556.1a
lsd	0.96	NS	0.326	0.88	7.20	14.19	715.10	1304.10
First sowing	42.8b	46.4	3.10a	5.02	49	60.1	3893.0	4263.2a
Second sowing	42.2b	46.1	2.80b	5.69	44.4	64.4	3784.3	3204.1ab
Third sowing	43.8a	41.5	3.20a	3.59	49.8	55.7	4095.8	2938.1b
lsd	0.83	NS	0.282	NS	NS	NS	NS	1129.1

Table (b)

Treatment	Infiltration rate (mm h ⁻¹)		Seasonal ET(133 DAS)		Grain yield, kg/ha, 133DAS		WUE _g , kg ha-mm ⁻¹ , (133 DAS)	
	Season I	Season II	Season I	Season II	Season I	Season II	Season I	Season II
Conventional tillage	2.9	1.93	338.8a	300.3	1430.6b	1489.0b	4.33	4.94
Double tillage	3.07	1.99	327.2b	299.9	1628.1ab	1849.9b	4.94	6.14
Furrow tillage	2.98	1.82	321.7b	302.0	1559.6ab	1700.0b	4.86	5.61
Strip tillage	3.12	2.07	324.4b	298.3	1798.2a	2544.9a	5.58	8.56
lsd	NS	NS	8.29	NS	346.8	462.9	1.74	
First sowing	3.01	1.98	312.1b	309.0a	1607.6	2235.3a	5.15	7.22
Second sowing	2.88	1.99	355.6a	300.0b	1573.8	1902.9ab	4.42	6.38
Third sowing	3.16	1.88	312.6b	291.4c	1631.0	1549.8b	5.22	5.33
lsd	NS	NS	7.18	5.15	NS	400.9	0.99	1.34

Legend: Values followed by the same letters are not significantly different from each other; NS=Not significantly different; DAS=days after sowing; lsd = least significant difference; WUE_g = water use efficiency (grain basis); LAI = leaf area index