

**MOLECULAR CHARACTERIZATION OF MICROORGANISMS WITH
INDUSTRIAL POTENTIAL FOR METHANE PRODUCTION IN SLUDGE FROM
KANGEMI SEWAGE TREATMENT PLANT, NYERI COUNTY- KENYA**

ALLAN KIPTANUI KIMISTO

**A Thesis Submitted to the Graduate School in Partial Fulfilment of the Requirements
for the Master of Science Degree in Limnology of Egerton University**

EGERTON UNIVERSITY

JULY 2023

DECLARATION AND RECOMMENDATION

Declaration

This thesis is my original work and has not been presented in this university or any other for the award of a degree.

Signature:



Date: 13th July 2023

SM18/19024/18

Allan Kiptanui Kimisto

Recomendation

This thesis has been submitted for examination with our approval as University Supervisors

Signature:



Date: 13th July 2023

Geoffrey Ong'ondo (Ph.D)

Biological sciences department

Egerton University

Signature:



Date: 13th July 2023

Anastasia Wairimu Muia (Ph.D)

Biological sciences department

Egerton University

COPYRIGHT

©2023 Allan Kiptanui Kimisto.

All rights reserved. No part of this thesis or the information contained herein may be reproduced, stored in a retrieval system or transmitted in any form or by any means, photocopying, scanning, recording or otherwise, without the permission of the author or Egerton University.

DEDICATION

I dedicate this work to my mother and siblings for their exemplary patience, support, and encouragement. The work is also dedicated to my entire family who gave me moral support, not forgetting my fiancée and all others who assisted me in achieving this thesis.

ACKNOWLEDGEMENTS

In humility, I would like to thank the Almighty God for His sustenance and guidance. I wish to thank Egerton University for the opportunity to study in the institution. I am sincerely grateful to Florian from the Rotary Club of Vienna through the LWM office at Egerton University for awarding me the fellowship to undertake this study. I am particularly indebted to Prof. Nzula Kitaka, the program coordinator for LWM/RCV, Dr. Geoffrey Ong'ondo, and Dr. Wairimu Muia for their thorough guidance and goodwill. I appreciate LWM Programme and Biological Sciences Department for providing the necessary learning infrastructure. My sincere thanks also go to the Kenya Agricultural and Livestock Research Organisation (KALRO), Njoro Plant Breeding Station, for the facilities that were availed to me to me, especially in the KALRO Molecular Biology Laboratory throughout my entire research period. My sincere thanks also go to all lecturers and colleagues for any assistance and support accorded to me. My thanks are also extended to Ms. Priscilla Wangari, Mr. Erick Owino, and Mr. Eddison Musikoyo, all in the LWM program for logistical support, Mr. Lewis Mungai of the Biological Sciences Department for helping me with equipment acquisition, and Mr. Cyrus Kimani from KALRO who worked with me tirelessly in the laboratory during analysis, and to many others I have not mentioned here but who assisted me in one way or the other. I appreciate the assistance of staff from Nyeri Water and Sewerage Company through Engineer George Gathungu for allowing me to do my data collection in their Kangemi Sewage Treatment Works. I extend further thanks to my colleagues in the Limnology class at Egerton University for their significant enrichment in this work. Mainly, I acknowledge the patience and inspiration of my family by saying, Thank You all!

ABSTRACT

Sewage sludge (biosolids) is a by-product of the waste water treatment plants (WWTPs). Microbial consortia under anaerobic conditions are involved in the reduction of organic matter in the wastewater of such sludge to produce methane gas. However, in developing countries like Kenya, these microbes have not been fully identified in order to target them for the efficient harnessing of biofuel. In this study, wet sludge samples were collected using sterile containers from the two anaerobic digestion lagoons at Kangemi sewage treatment plant, Nyeri County Kenya, between September to December, 2022. This treatment plant is one of the best managed and accessible treatment plants in Kenya. RNA/DNA shield were then added to the samples and transported to the laboratory at 4°C and stored at -20°C. Total community DNA was extracted from samples using available ZymoBIOMICS™ DNA Miniprep Kit and sequenced using Shotgun metagenomics. Samples were analyzed using MG-RAST software which allowed for comparison of taxonomic and functional diversity as well as identification of microorganisms directly involved in various stages of methanogenesis pathways. In addition, physico-chemical parameters were measured *in-situ* from the sludge tank, the two sludge digestion lagoons, and the dry beds. Results showed that parameters such as bulk density (0.14 ± 0.03 and 0.24 ± 0.02 g/cm³), pH (5.53 to 6.52), EC (3.77 ± 0.05 and 4.03 ± 0.05 mS/cm) and TS ($12.66 \pm 0.48\%$ and $53.40 \pm 8.82\%$) recorded significant differences between raw and dry sludge respectively. The sludge temperature (24.910 ± 0.910 °C) and TS ($17.20 \pm 0.089\%$) in lagoon 2 were significantly higher than in lagoon 1 with temperature (24.36 ± 0.85 °C) and TS ($11.60 \pm 0.036\%$). Microorganisms identified from the sequences were directly involved in different stages of methane production with hydrogenotrophic methanogens, such as *Methanospirillum* (32%) or *Methanobacterium* (27%), being predominant in the lagoon communities, whereas acetoclastic *Methanoregula* (22%) and the acetate oxidating bacteria such as *Clostridia* (68%) were the key microbes for that pathway in the sewage sludge. Furthermore, the methylotrophic pathway was carried out by *Methanothermobacter* (18%), *Methanosarcina* (21%), *Methanosaeta* (15%) and *Methanospirillum* (13%), which appearing to play an important role in methane production. In contrast, *Methanosarcina* (23%), *Methanoregula* (14%), *methanosaeta* (13%) and *methnanoprevibacter* (13%) seemed to play an important role in the final step of methane release. This study concluded that the sludge produced from this WWTP harbours microbes with significant potential for biogas production besides being an abode for many other unique microbes. The study further recommends investigations into efficiency of the identified microbes for biogas production and reduction of the sludge parameters to the recommended levels for safe agricultural application.

TABLE OF CONTENTS

DECLARATION AND RECOMMENDATION	ii
COPYRIGHT	iii
DEDICATION.....	iv
ACKNOWLEDGEMENTS	v
ABSTRACT.....	vi
LIST OF FIGURES	x
LIST OF PLATES	xii
LIST OF TABLES	xiii
LIST OF ABBREVIATIONS AND ACRONYMS	xiv
CHAPTER ONE	1
INTRODUCTION.....	1
1.1 Background information	1
1.2 Statement of the problem	3
1.3 Objectives.....	4
1.3.1 General objective.....	4
1.3.2 Specific objectives	4
1.4 Hypotheses	4
1.5 Justification of the study	4
1.6 Definition of terms	5
CHAPTER TWO	7
LITERATURE REVIEW	7
2.1 Wastewater sludge treatment technologies in the tropics	7
2.2 Characteristics and treatment of wastewater sludge	8
2.2 Sewage sludge treatment in Kenya	12
2.3 Microbial ecology of sludge.....	13
2.3.1 Viruses	14
2.3.2 Bacteria.....	14
2.3.3 Archaea.....	16
2.3.4 Protozoa.....	18
2.3.5 Fungi.....	19
2.4 Methanogenic genes in microorganisms	19
2.5 Physicochemical factors affecting methanogenesis	21
2.6 Methods of characterization of microbial methanogens	22

CHAPTER THREE	25
MATERIALS AND METHODS	25
3.1 The study site	25
3.2 Sampling sites	27
3.2.1 Sampling and field measurements	28
3.2.2 Determination of physicochemical properties of NYEWASCO-Kangemi WWTP	29
3.3 Molecular characterization of microorganisms.....	32
3.3.1 DNA extraction.....	32
3.3.2 Whole-genome shotgun metagenomics method.....	33
3.4 Data analysis	34
3.4.1 Analysis of Physicochemical properties data	34
3.4.2 Analysis of whole-genome shotgun metagenome sequencing data	35
3.5 A summary of the methods used in the study	37
3.6 Research authorization	38
CHAPTER FOUR.....	39
RESULTS	39
4.1 Physicochemical properties of sludge	39
4.1.1 Physicochemical properties of sludge in the anaerobic sludge digestion tanks	39
4.1.2 A comparison of physico-chemical properties of sludge in the sludge tank (raw sludge) and dry beds (composted sludge) composite samples	42
4.2 Microbiological parameters.....	46
4.2.1 The Shotgun metagenomics data sets of microbial community in this study	46
4.2.2 Sequenced data quality metrics	48
4.2.3 Taxonomic profiling	48
4.2.4 Taxa abundance	49
4.2.5 Comparative metagenomics analysis of microorganisms in lagoon 1 and lagoon 2....	55
4.3 Functional profiling of methanogenic microbial community	73
4.3.1 General functional profiles of the two lagoons	73
4.3.2 Functional profiles of relevant metagenomics pathways√	75
CHAPTER FIVE	111
DISCUSSION	111
5.1 Physicochemical properties of sewage sludge	111
5.2 Physicochemical parameters of the sludge digestion tanks	114

5.3 The sludge microbial communities	116
5.4 The methane producing communities	119
CHAPTER SIX	123
CONCLUSIONS AND RECOMENDATIONS	123
6.1 Conclusions	123
6.2 Recommendations	123
REFERENCES.....	125
APPENDICES	152
Appendix A: Statistical analyses for the physico-chemical parameters comparing the raw and the dry beds sludge	152
Appedix B: PCoA clustering of the composite samples	153
Appendix C: Composition of top 20 functional categories for all sample(s).....	153
Appendix D: Database sources for the hits distribution.....	154
Appendix E: NACOSTI Research Permit.....	155
Appendix F: NYEWASCO research permit	156
Appendix G: Molecular characterisation paper	157
Appendix H: Physico-chemical characterisation paper	158

LIST OF FIGURES

Figure 1: Energy efficient sewage sludge treatment process.....	7
Figure 2: Schematic Diagram of a sewage sludge treatment process.....	12
Figure 3: Woese and Fox’s three-domain phylogenetic tree of life.....	15
Figure 4: The genreal methanogenesis pathways	17
Figure 5: Three pathways for methanogenesis namely (A) acetoclastic pathway, (B) hydrogenetrophic pathway, (C) methylotrophic pathway and (D) the final stage of methane production.	20
Figure 6: A Satellite Map of Kenya showing location of Kangemi WWTP and the sampled sites	26
Figure 7: Schematic diagram showing the sampling points	27
Figure 8: A flow diagram summarizing the materials and methods in this study.	38
Figure 9: The textual triangle diagram for classification of sludge	46
Figure 10: The k-mer rank abundance graph plotting the k-mer coverage as a function of abundance rank, with the most abundant sequences.....	47
Figure 11: This graph shows the fraction of base pairs of each type (A, C, G, T, or ambiguous base N) at each position	47
Figure 12: An interactive plot generated by Krona on the different hierarchies of metagenomics classification of bacteria in lagoon 1 and 2.....	50
Figure 13: An interactive plot generated by Krona on the different hierarchies of metagenomics classification of Archaea in lagoon 1 and 2.....	52
Figure 14: An interactive plot generated by Krona on the different hierarchies of metagenomics classification of Eukaryote in lagoon 1 and 2.....	54
Figure 15: Bar plot(s) showing the taxonomic abundance across the samples at phylum taxa level.....	55
Figure 16: An interactive plot generated by Krona on the different hierarchies of metagenomics classification in lagoon 1 and 2.....	57
Figure 17: Bar graph showing the class dominance in the two lagoons	59
Figure 18: Bar graph showing the family dominance in the two lagoons	60
Figure 19: Bar graph showing the genera dominance in the two lagoons.....	62
Figure 20: Composite sample 1b rank abundance plot by genus.....	63
Figure 21: Composite sample 1c rank abundance plot by genus.....	65
Figure 22: Composite sample 2a rank abundance plot by genus.....	67
Figure 23: Composite sample 2c rank abundance plot by genus	68

Figure 24: Alpha diversity plots showing the range of α -diversity values in the composite samples 1b,1c, 2a and 2c data sets computed by MG RAST.	69
Figure 25: Principal coordinate analysis (PCoA) of four composite samples at for various taxa.....	71
Figure 26: Principal coordinate analysis (PCoA) of four composite samples	73
Figure 27: Composition of the functional categories across the samples.....	74
Figure 28: Relative abundance of hits annotated to the different methanogenesis related genes. ...	79
Figure 29: Genus level profiles of mcr genes annotated profiles in sample 1b.....	82
Figure 30: Genus level profiles of mcr genes annotated profiles in sample 1c	84
Figure 31: Genus level profiles of mcr genes annotated profiles in sample 2c	86
Figure 32: Cytoscape phylogenetic tree diagram for archaea species annotated to mcr methanogenesis genes.....	88
Figure 33: The abundance of the mcr-annotated methanogens in the different samples.....	89
Figure 34: Genera composition of archaea profiles from fmd annotation.....	93
Figure 35: Abundance of the different genera of archaea in the hydrogenotrophic	94
Figure 36: Genera composition of bacterial profiles from fmd annotation	95
Figure 37: Abundance of the different genera of bacteria in the hydrogenotrophic pathway	96
Figure 38: Abundance of the different genera of archaea in the acetoclastic pathway	99
Figure 39: Composition of archaeal cdh-annotated profiles in the composite samples	100
Figure 40: Abundance of the different genera of bacteria in the acetoclastic pathway.....	101
Figure 41: Composition of bacterial cdh-annotated profiles in the four samples.....	102
Figure 42: Abundance of the different genera of archaea in the methylotrophic pathway.....	106
Figure 43: Composition of the archaea community in the methylotrophic pathway' profiles....	107
Figure 44: Abundance of the different genera of bacteria in the methylotrophic pathway	108
Figure 45: Composition of the bacterial community in the methylotrophic pathway' profiles ..	109

LIST OF PLATES

Plate 1: Photographs showing (a) the sludge tank or well, (b) Sludge digestion lagoon-P1 (C) Sludge digestion lagoon-P2 and (d) sludge drying beds located at NYEWASCO-Kangemi WWTP 28

Plate 2: Photographs Showing (e) Sampled Drying Bed 1, (f) Sampled Drying Bed 2, (g) Sampled Drying Bed 3 and (f) Sampled Drying Bed 4 located at NYEWASCO-Kangemi WWTP 28

LIST OF TABLES

Table 1: Concentration and purity of the total extracted DNA from the samples collected at Nyeri-Kangemi wastewater treatment plant.	33
Table 2: Metagenome data reads for lagoon 1 and lagoon 2	34
Table 3: Means of physicochemical parameters collected <i>in situ</i> in the sludge digestion lagoons (mean (n) \pm standard deviation)	39
Table 4: Means and standard deviation of physico-chemical properties of composite samples analysed in the laboratory	41
Table 5: Physicochemical properties of sludge tank and dry bed composite samples	43
Table 6: Concentration of selected metals (Means \pm SD)	45
Table 7: The raw and dried sludge texture.....	46
Table 9: Taxonomic profiling metrics per sample	49
Table 10: Number of reads assigned to different kingdoms for samples from lagoons 1 and 2	49
Table 11: ANOVA test for the functional groups.....	74
Table 12: Common alpha diversity indices of the samples	75
Table 13: Bray-Curtis's beta diversity of (dis)similarity	75
Table 14: Alpha diversity indices for the total methane functional categories.....	76
Table 15: Bray-Curtis similarity analysis of the samples	77
Table 16: Alpha diversity of the methanogenesis related genes.....	78
Table 17: ANOVA analysis of the mcr profiles	80
Table 18: <i>Dunn's Post Hoc test for mcr profiles</i>	80
Table 19: Diversity of species annotated to for the <i>mcr</i> genes	81
Table 20: Diversity indices of profiles annotated to fmd gene	91
Table 21: Bray-Curtis similarity index among the samples as annotated by fmd	91
Table 22: Diversity indices for cdh profiles	98
Table 23: ANOVA test for the cdh profiles.....	98
Table 24: Bray-Curtis similarity index for cdh profiles in the different samples.....	99
Table 25: ANOVA analysis for methylotrophic pathway profiles	104
Table 26: <i>Dunn's post hoc test for the methylotrophic pathway' profiles</i>	104
Table 27: Diversity indices for methylotrophic pathway' profiles	105
Table 28: Biochemical reactions and their corresponding ORP values in wastewater sludge (Environmental, 2008).	116

LIST OF ABBREVIATIONS AND ACRONYMS

16S r RNA	16 Small Sub-unit Ribosomal Ribonucleic Acid
A	Adenine
ADR	Artificial Duplicate Reads
AmoA	Ammonia monooxygenase
ANOVA	Analysis of variance
APHA	The American public health association
BGP	Border Gateway Protocol
BP	Base pairs
C	Cytosine
C/N	Carbon and Nitrogen ratio
CDH	dehydrogenase/acetyl-CoA synthase (cdh)
CDNAs	Complementary Deoxyribonucleic acid
Coenzyme B	7-mercaptoheptanoylthreoninephosphate
Coenzyme M	2-mercaptoethanesulfonate
D	Dominance
DGGE	Denaturing Gradient Gel Electrophoresis
DHS	Down-flow hanging sponge
DNA	Deoxyribonucleic acid
DNTPs	Deoxyribonucleotide triphosphate
DO	Desolved Oxygen
DRISEE	Duplicate Read Inferred Sequencing Error Estimation
EC	Electrical Conductivity
EDTA	Ethylenediaminetetraacetic acid
F420	8-Hydroxy-5-deazaflavin
FISH	Fluorescence <i>In Situ</i> Hybridization
FMD	formyl methanofuran dehydrogenase
G	Guanine
Gb	Giga bytes
H'	Shannon-Wiener Index
H4MPT	Tetrahydromethanopterin
HPC	Plate Count Media
ISO	International Organization for Standardization

HQ	High quality
HS-HTP	N-7 mercaptoheptanoylthreonine phosphate
IEC	International Electro-technical commission
K-MER	A sequence of k characters in a string
KNBS	Kenya National Bureau of Statistics
KO	Kyoto encyclopaedia of genes and genomes
LQ	Low quality
LSD	Least Significant Difference
MCR	methyl Coenzyme M reductase
MEGA	Molecular evolutionary genetics analytics
MG-RAST	An open source, open submission web application server
MTA	methyl transferase
MTM	methylamine methyl transferase
NACOSTI	National Commission for Science, Technology, and Innovation
NCBI	National Centre for Biotechnology Information
NGS	Next-Generation Sequencing
NYEWASCO	Nyeri Water and Sewerage Company
ORP	Oxidation-reduction potential
OTUs	Operational Taxonomic Units
PAH	Polycyclic Aromatic Hydrocarbons
PCR	Polymerase Chain Reaction
PCBs	Polychlorinated biphenyls
PcoA	Principal Coordinate Analysis
QGIS	Quantum geographic information system
QPS	Quantitative Prortagol Staining
SDA	Sabouraud Dextrose Agar
RefSeq	Reference sequence
SAOB	Syntrophic Acetate-Oxidizing Bacteria
SDG	Sustainable Development Goals
SPR	Subtree-Pruning-Regrafting
SSU rRNA	Small Subunit Ribosomal Ribonucleic Acid
T	Thymine

TBE	Tris-Borate-EDTA buffer
TDS	Total Dissolved Solids
TMAO	Trimethylamine N oxide
TOC	Total organic carbon
TOM	Total organic matter
TON	Total organic nitrogen
TOP	Total organic phosphorus
TRFL	Terminal Restriction Fragment Length Polymorphism
TRFL	Terminal restriction frequent length polymorphism
TS	Total Solids
TSA	Trypton Soya Agar
UASB	Up-flow anaerobic sludge blanket
US EPA	United States Environmental Protection Agency
VAT	Value Added Tax
WEF	Water Environmental Federation
WHO	World Health Organization
VS	Volatile Solids
WWTPs	Wastewater Treatment Plants

CHAPTER ONE

INTRODUCTION

1.1 Background information

The biological treatment of wastewater generates a tremendous amount of sludge (bio-solids). Disposal of the sludge poses a challenge to many wastewater treatment plants (WWTP). Nevertheless, the same sludge has a potential for reuse in many ways as energy, biofertilizer, and construction material sources (Sartorius, 2011). Generally, sewage sludge treatment involves reducing sludge weight and volume to lower disposal costs and minimize potential health risks of disposal options (Rehman *et al.*, 2015). The treatment processes occur by decreasing the raw sewage in volume through stages of digestion (US EPA, 2012).

In many developed countries, the treatment processes may include thickening, dewatering, mesophilic anaerobic digestion, aerobic digestion, Omni-processing, thermal depolymerization, thermal hydrolysis, phosphorous recovery, and more complex technologies such as phytoremediation (Sartorius, 2011; US EPA, 2012). However, in developing countries like Kenya, the existing sludge treatment infrastructures are not sufficient in treating all the sludge generated sustainably as required in a circular economy (Bora *et al.*, 2020), majorly due to a lack of funds to properly maintain and upgrade existing plants over time (Rehman *et al.*, 2015).

Sewage sludge with high organic load, due to poor treatment, causes many ecological problems when released into receiving water bodies (Andreoli *et al.*, 2007; Manh, 2008; Rorat *et al.*, 2019) or the environment in general. It may result in eutrophication that affects aquatic flora and fauna; alters physical and chemical properties of the soil, thus affecting the suitability of the land for crop production; and makes the water unfit for drinking (Manu, 2011) due to increased health risks. Therefore, environmental agencies and governments are interested in developing practical and long-lasting solutions for wastewater treatment. One option is using biotechnological processes to convert the wastewater sludge into environmentally friendly forms through energy production (Bora *et al.*, 2020; Shivsharan *et al.*, 2013) and for agricultural use.

Limited research studies have been done on the ecology of wastewater sludge, and very few focus primarily on microbiological investigations (Ge *et al.*, 2014; Hirakata *et al.*, 2016; Strong *et al.*, 2015). The biotechnological studies have focused mainly on the molecular characterization of members of bacteria due to their large populations in sludge systems. However, Hirakara *et al.* (2015) reported that eukaryotic populations (protists such as *Colpidium campylum*; a free-swimming ciliate) are the predators of prokaryotes and have a

significant impact on the composition and function of the co-existing prokaryotic populations. Nevertheless, the effects of prokaryotic communities in anaerobic environments have not been examined in detail (Hirakata *et al.*, 2016). Thus, the role of protists in methanogenesis has mostly been overlooked, and the influence of protists needs to be considered to obtain a better understanding of the structure and function of the microbial community in methanogenesis.

Even though the microbial community in sludge possesses excellent potential as a biofuel energy source, appropriate microbial identification techniques have not been applied to exploit it. Therefore, the sludge has been considered a 'black box with possible unexploited biotechnological reactions (Lim, 2018). Culture and isolation-dependent methods do not present the actual methanogenesis reaction in sludge since most microorganisms within the sludge communities cannot be cultured *in vitro* (Blasco *et al.*, 2017). Significant advancements in microbial studies have been made in recent years, and nucleic acid-based molecular methods can identify methanogenic microorganisms by DNA sequencing of their ribosomal RNA (r RNA) genes without isolating the microorganisms (Lim, 2018).

In Kenya, the biotechnological production of energy from wastewater sludge is a potential venture for a relatively efficient, low-cost wastewater-sludge treatment system. The Nyeri Water and Sewerage Company (NYEWASCO)-Kangemi wastewater treatment plant is one of Kenya's modern and best-managed WWTP. Its system can also be upgraded to include biogas production, which is currently lacking. Even-though the general climatic condition may not favour the biogas production, the specific environmental variables in the anaerobic sludge are within the required ranges of methanogens survival and can be further engineered for optimum production. However, it is vital to have preliminary baseline information on the profile of the microbial composition of the sludge from the WWTP. In addition, identifying the microorganisms which metabolize the organic compounds in the wastewater sludge to produce the energy (methane) is vital. This will provide tangible evidence for a cheaper alternative energy source for the Nyeri-Kangemi WWTP and provide information on the biological properties and possible application of biotechnology, including genetic modification of methanogenic organisms for technical applications (Blasco *et al.*, 2017).

This study identified microorganisms such as protists, bacteria, and archaea in the wastewater sludge from the Nyeri-Kangemi WWTP using the metagenomics method. The shotgun metagenomics techniques will characterize the microorganisms. The genes will be predicted using the *de novo* gene prediction pathways (Pyzik *et al.*, 2018) and provide microbial diversity and help detect their abundances in the sludge samples. The functional

methanogenic annotation will be performed by classifying predicted metagenomics proteins into protein families using sequence or hidden Markov models (HMM) databases (Giwa *et al.*, 2019).

1.2 Statement of the problem

Sewage sludge is composed of unique anaerobic conditions that typically support the growth of various microbial organisms. Even though there has been evidence of the roles played by bacteria in the degradation of organic matter in such environments, minimal work focusing on the methanogen's ecology has been undertaken for this ecosystem. However, it is known that sewage sludge methanogens produce methane gas that contributes to climate change when released into the atmosphere; this leads to global warming and the need to harness it as a sustainable energy source. This energy source has been vastly underutilized in developing countries such as Kenya. In most wastewater treatment plants in Kenya, over 70% of the solid waste and sludge is sent to landfills or dumped (sometimes illegally) in undesignated areas. One of the main challenges contributing to this is the lack of appropriate infrastructure and the technical expertise needed to manage the wastewater sludge properly.

Additionally, the inadequate of financial resources to invest in advanced sludge treatment methods contributes to ecological problems in the receiving water bodies. Despite these throwbacks, there is a need to reduce further the negative impacts of the partially treated sludge on the receiving water bodies, the lithosphere, and the atmosphere. This study investigated the general composition of microorganisms found in NYEWASCO-Kangemi sewage sludge between September to December, 2022, and specifically identified methanogens with methane production potential by metagenomics studies by annotating the metagenomics sequences obtained against the RefSeq, KO, and subsystems database using the MG-RAST pipeline. Methanogens and their associated microbes were identified by HMM search of methanogenic related sequences in the MetAnnotate platform by focusing on genes encoding methyl CoM reductase (*mcr*), formyl methanofuran dehydrogenase (*fmd*), dehydrogenase/acetyl-CoA synthase (*cdh*), methyl transferase (*mta*) and the methylamine methyl transferase (*mtm*, *mtb*, *mtt*) enzymes involved in the methanogenesis process.

1.3 Objectives

1.3.1 General objective

To determine of microorganisms with industrial potential for biogas production from sewage sludge using molecular method.

1.3.2 Specific objectives

- i. To determine the Physico-chemical parameters (such as temperature, electrical conductivity (EC), total solids (TS), and Volatile Solids (VS) and pH) of wastewater sludge at the Nyeri-Kangemi sewage treatment plant at the different sampling points.
- ii. To determine the diversity of microorganisms from the sewage sludge using shotgun sequencing metagenomics from the different sampling points.
- iii. To determine the diversity of microorganisms from the sewage sludge with potential application in enhancing methane production from the different sampling points.

1.4 Hypotheses

- i. There are no significant differences in the physico-chemical parameters (such as temperature, electrical conductivity (EC), total solids (TS), and Volatile Solids (VS) and pH) of sewage sludge from the different sampling points.
- ii. There are no significant differences in diversity of microorganisms from the different sampling points in Nyeri-Kangemi sewage sludge.
- iii. There are no significant differences in the diversity of microorganisms with potential of enhancing production of methane from different sampling points

1.5 Justification of the study

Sewage sludge environments provide distinct biotopes inhabited by microorganisms with industrial potential for bio-energy production. The anaerobic conditions in NYEWASCO-Kangemi sewage sludge digesters provide an environment that is expected to support methanogens and their associates. This study enhances our understanding of the general composition of microbes found in this sewage sludge ecosystem. The study identified those microorganisms with genes encoding enzymes responsible for the methanogenesis process and the final release of methane gas. This study has potential economic impacts as the knowledge accrued can be applied for future bioenergy production. Therefore, utilizing these microorganisms for sustainable energy production is a cheap, renewable, and readily available source of energy. This also ensures that the primary function of the treatment works, which is removing pollutants and disease-causing pathogens to produce 'clean water,' is not interrupted by power outages since bioenergy produced can be used to power the plant operations as well as contribute to national power grids thus allowing them to be energy self-

sufficient and reduce their costs of operation and contribute to sustainable development. Unfortunately, benefits accruing from such studies are not evident in Kenya today compared to developed countries where tenets of the circular economy in waste management are being practiced. The methanogens reported in this study can be used as a starting point for industrial biogas production and other related exploitations. This study is a good beginning for registering our contributions to attaining SDG 13 on climate change, the Kenya Vision 2030, and the government's development agenda summarized by the need for environmental sustainability for socio-economic benefits. The whole-genome metagenomics applied in this study allows us to examine microbes (culturable and unculturable) in their natural environments without relying on artificial culturing and whole-genome examination to capture or amplify individual genomes. This method also takes an unbiased path to offer a comprehensive assessment of genome content in the community and thereby provides in-depth information on community composition and function. Microorganisms identified were very diverse, with a good number found to have a high potential for methane gas production. This discovery can go a long way in solving environmental problems associated with the disposal of sewage sludge and the production of sustainable energy that can be utilized to reduce the cost of operation of the NYEWASCO-Kangemi sewage works. Consequently, this will provide an avenue for biotechnological advancement in the production of sustainable green energy.

1.6 Definition of terms

Acetoclastic methanogens: These are anaerobic archaea converts acetic acid to methane.

Acidogenesis: A process by which. Acid forming bacteria hydrolyses the complex molecules of sludge fermenting them into various volatile fatty acids (VFAs)

Anaerobic digester: a sequence of processes by which microorganisms break down biodegradable material in the absence of oxygen

Cellular economy: a model of production and consumption of materials, which involves sharing, leasing, reusing, repairing, refurbishing and recycling existing materials and products as long as possible

Chemoorganotrophic: These organisms require organic substrates to get both carbon and energy for growth and development

Depolymerization: a process of converting polymer into a monomer or a mixture of monomers

Fasta: a text file format used for keeping genetic data

Hydrogenosomes: organelles that have evolved from mitochondria to provide another mechanism for anaerobic ATP synthesis utilizing pyruvate

Hydrolysis: the chemical breakdown of compounds due to chemical reaction with water

Mesophilic: microorganisms that grows best in moderate temperature, neither too hot nor too cold, typically 20°C to 45°C

Metagenomics: a study of collection of genetic material (genomes) from a mixed community of organisms irrespective of whether they can be cultured or not in order to provide knowledge of species present and their functionality information.

Methanogenesis: the process of generation of methane by anaerobic organisms called methanogens

Methylootrophs: a diverse group of microorganisms that can use reduced one-carbon compounds, such as methanol or methane, as the carbon source for their growth; and multi-carbon compounds that contain no carbon-carbon bonds, such as dimethyl ether and dimethylamine

Omni-processor: a range of physical, biological, or chemical treatments to remove pathogens from human generated faecal sludge, while simultaneously creating commercially valuable by products.

Sludge (bio-solids): thick, soft, wet mud or a similar viscous mixture of liquid and solid components, especially the product of an industrial or refining process

Syntrophic: is a mutualistic interaction in which two metabolically different types of microorganisms are linked by the need to keep metabolites exchanged between the two partners at low concentrations to make the overall metabolism of both organisms feasible.

CHAPTER TWO

LITERATURE REVIEW

2.1 Wastewater sludge treatment technologies in the tropics

The selection of a sewage treatment system is dependent mainly on the level of the social and economic conditions of a country (Tandukar *et al.*, 2007). In industrialized or developed countries, mostly found within the west (Zakkour *et al.*, 2001), the sludge treatment methods are more advanced and complex. This includes the Omni-processor, composting, mesophilic anaerobic digestion (MAD), thermal depolymerization, thermal hydrolysis, phosphorous recovery, and phytoremediation (Rehman *et al.*, 2015). This is due to their economic abilities and advanced microbiological and technological expertise to run and maintain these treatment methods under the changing extreme cold and hot climatic conditions (Raschid & Jayakody, 2008).

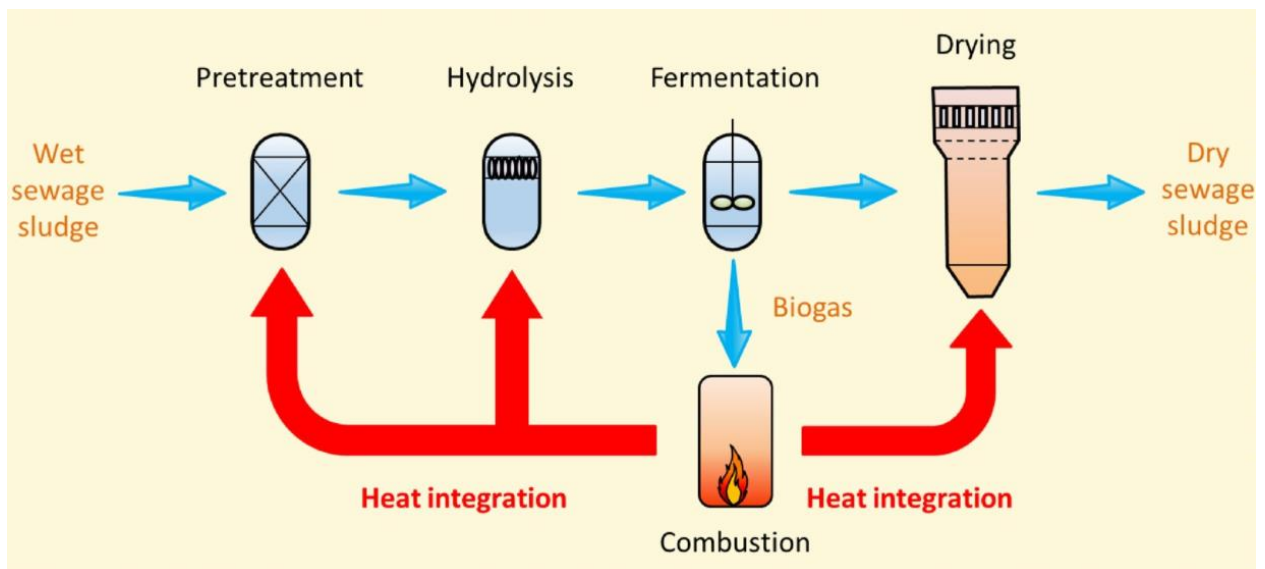

Figure 1: Energy efficient sewage sludge treatment process (Song *et al.*, 2019)

The wet sludge is first treated by thickening it in a gravity thickener and dewatered in the pre-treatment process to reduce its volume thus, enabling easy sludge handling (Seong *et al.*, 2020), as shown in figure 1. Sludge is then hydrolyzed into monomers before it undergoes acidogenesis, acetogenesis, and methanogenesis during the fermentation process. Biogas is harvested, and bio-solids are finally dried and discharged as dry sludge (Seong *et al.*, 2020) or processed into other environmentally green products (Bora *et al.*, 2020). This is typical in developed countries with enough resources.

In developing countries, primarily found in warm climatic regions (Lim, 2018; Mara, 2004; Von, 2007). There are limited financial and physical resources to treat wastewater, and the socio-economic situation and the context of urbanization create the conditions for unplanned and uncontrolled sludge use (Li *et al.*, 2011; Raschid & Jayakody, 2008; Wang *et al.*, 2014). The little resources available are allocated to the ‘immediate projects of economic significance such as road construction, the building of hospitals, among others (Tandukar *et al.*, 2007). Therefore, the wastewater sludge treatment processes in these countries entail mostly of the convectional anaerobic methods with the primary and secondary processes (Ujang & Buckley, 2002) and stabilization pond systems (Bora *et al.*, 2020). The warm climatic conditions are favourable for conventional treatment methods and there is no need for advanced wastewater treatment methods. The level of economic development in these countries cannot currently afford advanced infrastructure at the moment for wastewater treatment (Raschid & Jayakody, 2008). The anaerobic sludge treatment process in sludge tanks (lagoons) depends on the development of microbial communities under the prevailing physical chemical conditions to biodegrade sludge. Anaerobic sludge treatment efficiency has therefore not taken off for decades because the sludge microbial ecology was considered as a ‘black box’ with potential biological reactions due to a lack of appropriate microbiological techniques to exploit it (Lim, 2018).

2.2 Characteristics and treatment of wastewater sludge

Sludge is the accumulated solids, semisolids, or slurry residue produced as an end-product of wastewater treatment processes (Zhen *et al.*, 2017). The residue can either be classified as primary or secondary bio-solids. (1) Primary sludge is produced from chemical precipitation, sedimentation, and other primary processes, whereas (2) secondary sludge is the activated waste biomass resulting from biological treatments (Zhen *et al.*, 2017). Generally, sludge contains five components, namely, (i) non-toxic organic compounds (nitrogen and phosphorous) and (ii) toxic pollutants such as heavy metals (zinc, lead, copper, chromium, nickel, cadmium, mercury, arsenite), which may vary from less than 1ppm to 1000 ppm (Luo *et al.*, 2014), other components are (iii) organic pollutants, including PCBs, dioxins, pesticides, and nonyl-phenols (Wang *et al.*, 2005); (iv) pathogens, and (v) other microorganisms including the methanogens (Zorpas *et al.*, 2013). In warm regions, the Physico-chemical characteristics of sludge recorded are water content of 70% to 80%; and pH of dry sludge of about 6.5 to 9.0 (Zorpas *et al.*, 2011), the Electrical conductivity (EC) is about 3000 mS/cm (Zorpas *et al.*, 2013). Total phosphorous content is 20 to 30mg/l because of the enormous load of the treated municipal wastes. The C/N ratio is meager at below 10

for producing the high-quality final compost (Luo *et al.*, 2014). The organic matter is between 50-60%, while the TOC is about 30% (Zorpas *et al.*, 2011).

A study by Keffala *et al.* (2013) reported the C/N ratio of sludge at Bertrix wastewater below 10 and indicated its ability to act as a sink in the aquatic environment. Nitrogen and phosphorus were found to average at 2.5% and 1.1%, respectively, of the dry solids. Fe, Zn, Mn, Pb, and Cu were also recorded at high levels of above 10 mg/kg. They also recorded a significantly high concentration of helminth eggs at 1×10^{12} eggs/gram of sludge due to possible high prevalence resulting from poor socioeconomic conditions in the study area.

Papadopoulos *et al.* (2003) found that there may be different zones in an anaerobic pond which includes a high-density sludge zone with a water content of 87% at the bottom; while the zone above contained high biodegradable organic matter mainly made of volatile solids and was the most active zone where most of the degradation of the sludge occurred. The third layer was a volatile sludge containing 31.6% suspended and 47% volatile solids. This was the most biologically active layer of the sludge. A supernatant layer was composed chiefly of liquid low in suspended solids. It is worthwhile to note that different treatment processes as observed in Swaziland may have differences in sludge characteristics among them because different plants undergo different levels of treatment as well they have variable nature of pollutants; depending on inputs to wastewater, the fertilizer potential and pollutant risk of sewage sludge intended for agricultural application and as such has to be evaluated explicitly for each type of sludge (Mtshali *et al.*, 2014). This means that to determine the suitability in its use for agriculture and rates of application, and health risks from the pollutants, each sludge digester needs to be evaluated individually. There are very few data published on the physicochemical conditions of wastewater sludge in Kenya.

The sludge treatment process is essential in reducing the size of the final complex and hazardous sludge accumulation (Phan *et al.*, 2018). Therefore, it is crucial to consider the full range of sludge handling and disposal alternatives when planning sewage management strategies to reduce the final product to environmentally friendly levels. In some countries, sludge is still utilized directly as fertilizer in agriculture (Zhen *et al.*, 2017). In such countries, specific quality standard requirements of sludge applied in agriculture should be fulfilled; this helps prevent the accumulation of toxic substances, especially heavy metals, which might reach excessive levels in the soil after several applications.

Common sludge disposal methods include incineration, landfilling, agriculture, and forest land application (Kominko *et al.*, 2018). Various green technologies used in the valorization and manufacture of valuable products from wastewater sludge boost the

economy and a clean-up environment for sustainable development (Muia *et al.*, 2021). In Algeria, sludge is heated and converted to green cement as the ashes contain Aluminum Oxide and silicon (iv) oxide necessary for making cement (Samolada & Zabaniotou, 2014). Nikiema *et al.* (2013) recorded optimized and pelletized sludge in fertilizer production in Ghana and found that 3% gelatinized starch is the best material to bind dewatered sludge in fertilizer production. The sludge has components such as organic molecules and essential plant nutrients like nitrogen, phosphorus, potassium, and various trace elements (Kasza *et al.*, 2015). When stabilized through a composting process, it can become a good source of organic fertilizer and soil additive, free of chemicals and pathogens (Kominko *et al.*, 2018). Earthworms feed readily upon the sludge components, rapidly converting them into vermicompost, reducing the pathogens to safe levels, and ingesting heavy metals (Sinha *et al.*, 2010). The sludge can then be used as fertilizers, and the earthworms can be fed to poultry (Kasza *et al.*, 2015).

In Kenya, sludge has been used to make biofuel briquettes by the Nakuru Water and Sewerage Treatment Company (NAWASCO) due to the excellent calorific value, combustion rate, and flame temperatures for use as an alternative source of fuel to charcoal (Gold *et al.*, 2017). However, the combustion of briquettes produces ash, which poses a potential risk of producing hazardous waste due to its content of heavy metals and hence requires additional expenses in handling and disposal (Cieřlik *et al.*, 2015).

There are several disadvantages of using untreated or partially treated wastewater, sludge, or excreta, and the most obvious are the health risks from pathogens (WHO, 2006). The diseases are linked to the nature of the pathogens in the wastewater and thus vary locally depending on the local public-health pattern. The risks are also not limited to a particular population segment but can be observed in four groups: agricultural workers and their families; crop handlers; consumers of crops or meat and milk coming from cattle grazing on polluted fields; and those living on or near the areas where wastewater, sludge or excreta is used. Within these groups, the most vulnerable sections of the population are children and the elderly.

Anaerobic digestion of organic materials and pollutants in wastewater is an established technology for environmental protection which reduces sludge to more minor hazardous forms. These processes produce biogas, a mixture of methane and other gases like carbon dioxide, a valuable, renewable energy source (Raschid & Jayakody, 2008). Anaerobic digestion is a technologically simple process, with a low energy requirement, used to break down organic material from a wide range of wastewater types, solid wastes, and biomass into

methane. A much broader application of the technology is desirable in the current endeavours toward sustainable development and renewable energy production (Zhen *et al.*, 2017).

In the 1980's several projects were initiated in the Netherlands to produce biogas from organic wastes, but many of the projects were terminated due to insufficient economic viability (Raschid & Jayakody, 2008). Recently, methane production from organic wastes has been receiving renewed attention. It can potentially reduce CO₂ emissions via renewable energy production and limit the emission of the greenhouse gas methane, especially in animal manure (Zhang *et al.*, 2016). This trend is supported by the growing market demand for 'green' energy and the substantial optimization of anaerobic digestion technologies in the past decades, especially the development of modern 'high rate' and co-digestion systems (Zhang *et al.*, 2016).

2.2 Sewage sludge treatment in Kenya

The general wastewater sludge treatment process is as demonstrated in figure 2.

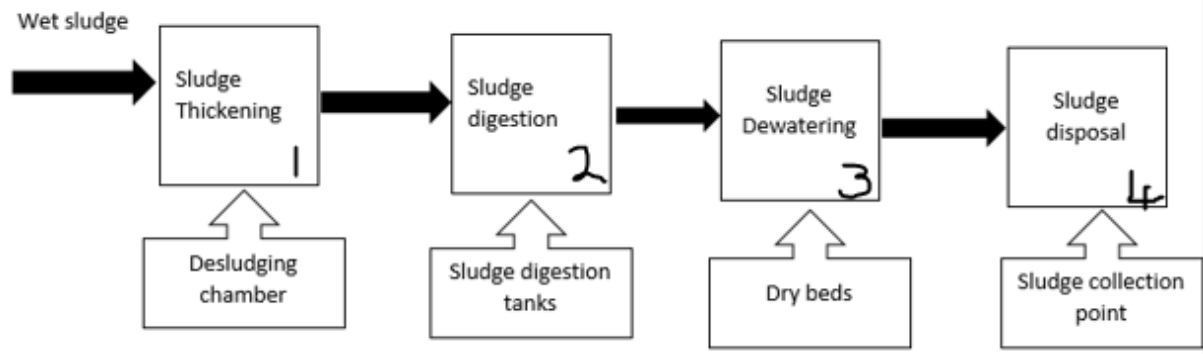

Figure 2: Schematic Diagram of a sewage sludge treatment process

The major steps in sewage sludge treatment (figure 2) are the (1) sludge thickening, where the sludge is collected in the desludging chamber and allowed to thicken by gravity over time to reduce the volume of sludge for easy handling (Strande & Brdjanovic, 2014). (2) The sludge is then allowed into digestion tanks or lagoons, where there is a biological process in which the organic solids present in the sludge are decomposed into stable substances. This process also helps reduce the total mass of solids while destroying any present pathogens and to enable easy dewatering (Müller, 2000). In the digestion tanks, anaerobic digestion by extracellular enzymes reduces complex sludge components to simpler ones for microbial uptake and energy generation. Acid-forming bacteria hydrolyse the large molecules fermenting them into various volatile fatty acids (VFAs) in acidogenesis, where other bacteria then act upon it to produce a mixture of carbon dioxide and methane (Strande & Brdjanovic, 2014). In addition, acetogenic bacteria convert the VFAs to acetic acid, carbon dioxide, and hydrogen. Finally, digester fermentation is completed by methanogenic archaea that combine either CO₂ and H₂ or acetate to methane gas (CH₄) (3). The sludge is allowed into the dry beds and dewatered over time before disposal (Müller, 2000). (4) After sludge has been effectively dewatered, it can be disposed of by (i) burying it underground in sanitary landfills or burned, or used as (ii) fertilizers by farmers (US EPA, 2012). It can also be used as (iii) soil conditioner for crops or ornamental plants, but care must be taken to ensure eggs of parasitic worms are not present or can safely be (Gold *et al.*, 2017).

The Nyeri-Kangemi wastewater treatment plant is one of the well-managed treatment plants in Kenya and is very effective in wastewater treatment (Kariunga *et al.*, 2018). The treatment plant has simple processes such as designing trickling filters, sedimentation tanks,

anaerobic lagoons, and maturation ponds. The sludge treatment process contains; (i) the desludging chamber, a tank that separates sludge and the liquid components through hydraulic pressure and desludges after every three (3) hours. In the wastewater treatment process, the raw sludge from the different desludging chambers is then pumped into the (ii) sludge well, where sludge is allowed to settle before it is pumped to (iii) the sludge lagoons. The sludge lagoons are digestion tanks where anaerobic digestion takes place for three to four months. Here the vegetation and scum are allowed to accumulate over time as part of the biological treatment of sludge and later on are removed. The treated sludge is then allowed through the underground valve to (iv), i.e., the drying beds by gravity. The dry beds are fitted with concrete slabs with spacing between the water from dewatering to infiltrating to the ground. The sludge is allowed to dry for a month during the wet season and fourteen days during the dry season before being sold to farmers for agricultural application. The plant produces between 75 to 250 tons of dried-up sludge per month. The sludge is sold at USD 5 per ton, making a profit of around USD 330 to USD 1100 per month from sewage sludge (NYEWASCO, 2007).

2.3 Microbial ecology of sludge

The microbial composition of sludge varies with many factors such as the community of water users, usage rates, dietary habits, culture, and general lifestyles (Chan *et al.*, 2005). For example, people with gastrointestinal upsets who might be carrying pathogens will also likely excrete harmful bacteria in large numbers, unlike the healthy individuals who might excrete large numbers of harmless bacteria (Seviour & Nielsen, 2010).

Meerburg *et al.* (2016) record that sludge communities are specialized and have lower species diversity than a biological filter. They explain that the community is dominated by heterotrophic bacteria both contained in sludge flocs and dispersed in the liquid. The bacteria and the saprophytic protozoans from the basic trophic levels are followed by holozoic protozoans that feed on the bacteria (Garcia *et al.*, 2000). Unless fungi are poor in abundance in specific bulking conditions, algae are usually absent, but rotifers and nematode worms may be present (Garcia *et al.*, 2000).

Understanding the ecological behavior of sludge may be difficult because of the mixed populations and the substrate's complex nature, which is controlled by flow rate and concentrations of inflows (Luostarinen *et al.*, 2009). Explanations based on kinetic theory and the ecological behavior of organisms in sludge have proposed that under steady conditions, the growth rate of sludge organisms is equivalent to the mass of organisms removed in unit

time during sludge harvesting (Brdanovic, 1998; Liu & Tay, 2002; Makinia, 2010; Meerburg *et al.*, 2016; Soddell & Seviour, 1990). These organisms may include viruses, bacteria, fungi, and protozoans and are discussed in ensuing sub-sections.

2.3.1 Viruses

Raw sewage and sludge communities contain many enteric viruses excreted by human beings in their feces, including the *Rotaviruses* (Okoh *et al.*, 2010), *Adenoviruses*, *Caliciviruses*, *Noroviruses*, *Hepatitis A virus*, *Enterovirus*, and *Poliovirus* genera. These viruses pose a severe health hazard potential if allowed to contaminate food and water supplies (Enzmann *et al.*, 2018). These viruses are removed through sludge dewatering and solar drying in drybeds (Kuffour, 2010).

Bacteriophages are always present whenever bacterial hosts are available (Chibani *et al.*, 2004), although they are relatively poorly understood (Otawa *et al.*, 2007). The phages are likely considerable if the phages bacteria ratio is similar to other aquatic habitats where greater than 10:1 would give up to 10^{12} ml⁻¹. These may also be underestimates (Seviour & Nielsen, 2010). These help in controlling the number of bacteria in this environment.

2.3.2 Bacteria

Bacteria are a group of unicellular organisms with a majority having cell walls but lacking organelles and an organized nucleus. They are characterized by a lipid bilayer cell membrane containing fatty acids (Pandur & Stopar, 2021). The phylogenic position of bacteria in the tree of life is shown in Fig.3. In wastewater sludge, they are represented mainly by the phyla, *Proteobacteria*, *Bacteroidetes*, *Acidobacteria*, *Firmicutes*, and *Nitrospirae* (Nguyen *et al.*, 2019). Over the years, the bacteria community of particular interest has been those responsible for removing the nutrients phosphorus and nitrogen from sludge (Beer *et al.*, 2006). The numbers of bacteria in sludge tanks have been estimated to be between $1^{-10} \times 10^{12}$ cells/g total counts, regardless if they are alive or dead (Seviour & Nielsen, 2010). Available information suggests that chemoorganoheterotrophic bacteria are the majority population (Seviour & Nielsen, 2010). Where culture-dependent methods are used in nutrient-rich media, this will favor their growth and, therefore, detect *Gammaproteobacteria* (Spring *et al.*, 2004). DNA analysis using 16s RNA sequence using both the FISH and clone library data suggests that the subgroup of the *Beta proteobacteria*, such as the members of the *Comamonadaceae* and the *Acidovorax spp.*, are among the dominant bacteria (Seviour & Nielsen, 2010).

Denitrifying bacteria are also present mainly in wastewater plants capable of nitrogen removal (Rajta *et al.*, 2020). This is because they can grow and assimilate on respirable

substrates like acetate or the methanol in the presence of NO^2 or NO^3 (Nakasaki *et al.*, 2019). The dominant denitrifiers in sludge are unclear because the ability to denitrify is so widespread, and the populations vary between different plants with changes in influent and operational conditions (Seviour & Nielsen, 2010). The potential denitrifying candidates shown so far includes the *Aquaspirillum*, *Azoarcus* and the *Thaurea* species detected in plants designed to remove Nitrogen (Morgan *et al.*, 2008). The species *Azoarcus spp*, *Thauera spp*, and *Zoogloea spp* have been proposed to be the dominant denitrifiers in industrial plants (Yang, 2019).

The nitrifying bacteria include the *Nitrobacter spp* and the *Nitrospira spp*. Nitrification in sludge is not carried out by the uncultured *Nitrospira spp* (Seviour & Nielsen, 2010). Other bacteria that are usually present include the sulfur-oxidizing bacteria, the glycogen accumulating bacteria such as the *Actinobacteria*, polymer degrading bacteria such as members of the *Saprosiraceae*, the iron bacteria such as the iron-reducing *Geobacter sulfurreducens*, the sulfate-reducing bacteria such as the *Desulfovibrionaceae* and *Desulfobacteriaceae* families, PAH accumulating bacteria such as the *Acinetobacter spp* among others (Seviour & Nielsen, 2010).

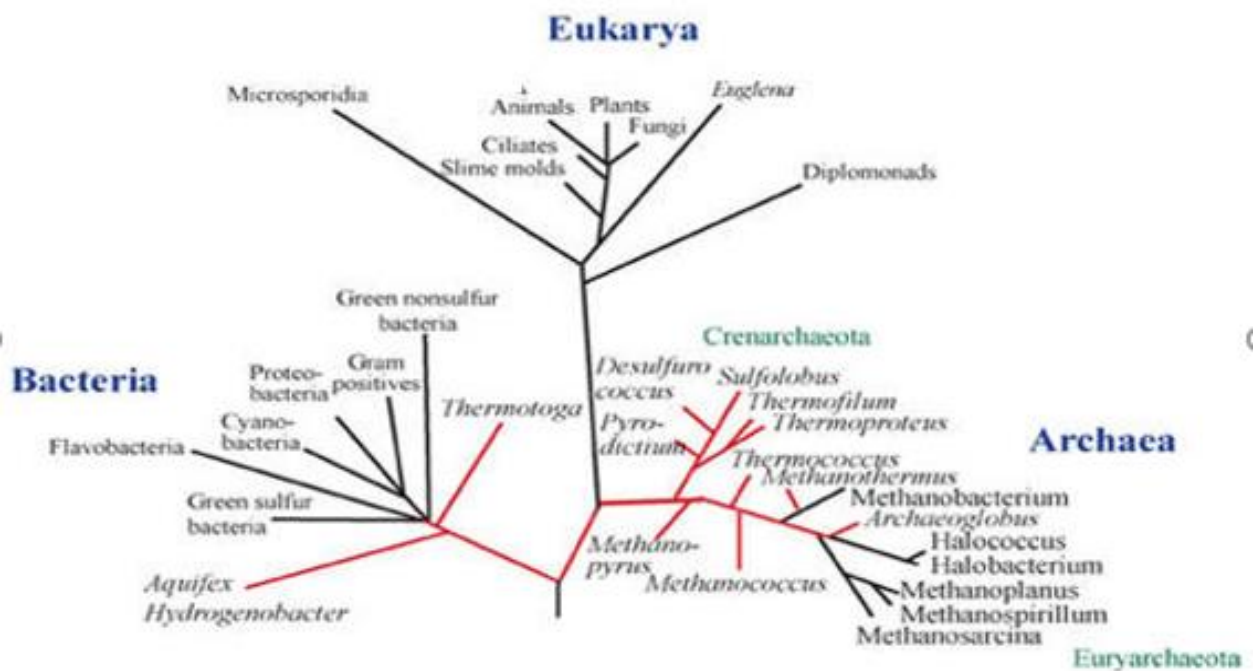

Figure 3: Woese and Fox’s three-domain phylogenetic tree of life. Modified from Bartee *et al.* (2017).

2.3.3 Archaea

Archaea are unicellular prokaryotic organisms distinguished by phytanyl's presence on the cell membrane (Pandur & Stopar, 2021). Fig. 3 shows the major archaeal groups in the tree of life. The methanogenic Archaea occur in sludge despite their small numbers of less than 1% of the total cells (Gray *et al.*, 2002). Whether they actively grow in the sludge or are seeded from the sewers is unclear because only a few studies have explored these communities (Ren *et al.*, 2008). The commonly occurring nitrifying members are mainly the archaeal ammonia-oxidizing organisms derived from the PCR analysis targeting the *amoA* genes of the phylum *Crenarcheota* (Park *et al.*, 2006). The members of this domain are considered to be widely distributed ecologically, and more molecular analysis should be carried out to give insight into their roles (Seviour & Nielsen, 2010).

It has long been believed that methanogenesis originated within the phylum Euryarchaeota. However, the discovery of putative methanogenic genes in members of *Bathyarchaeita* has surfaced, hinting that methanogenesis might be phylogenetically widespread (Vanwonterghem *et al.*, 2016). New evidence of methyl coenzyme M reductase genes in the archaeal population genome from anoxic environments with high methane flux has been discovered in new archaeal phyla such as the *Verstraetearchaeota* (Vanwonterghem *et al.*, (2016). Chistoserdova (2011), while investigating the modularity of methylotrophy, argued that the knowledge gained over the years had shed more light on the role of methylotrophy modulating microbes such as; *Methylococcus*, *Methylobacterium*, *Methylacidiphilum*, *Nitrococcus*, *Methylophaga* among others as methylotrophic bacteria revealing the existence of alternative enzymes and pathways for specific metabolic goals. This suggests the need for more studies to understand methanogenic diversity. The new knowledge from advanced microbial technologies is changing the understanding of the global carbon cycles, and therefore more research is needed.

Methanogenesis

Methanogenesis is how microbes (commonly known as methanogens) produce methane (Katz, 2011). According to Kietavainen and Purkamo (2015), methanogenic organisms identified belonging to the domain of Archaea are a group phylogenetically distinct from bacteria and eukaryotes. Methane production is an essential aspect of microbial metabolism, which is significant for natural gas accumulation and has wide applications (Cramer & Franke, 2005). The two best-described pathways (Eq 1 and 2) for methanogenesis

are the process where acetic acid and inorganic carbon dioxide act as the terminal electron acceptors (Thauer, 1998).

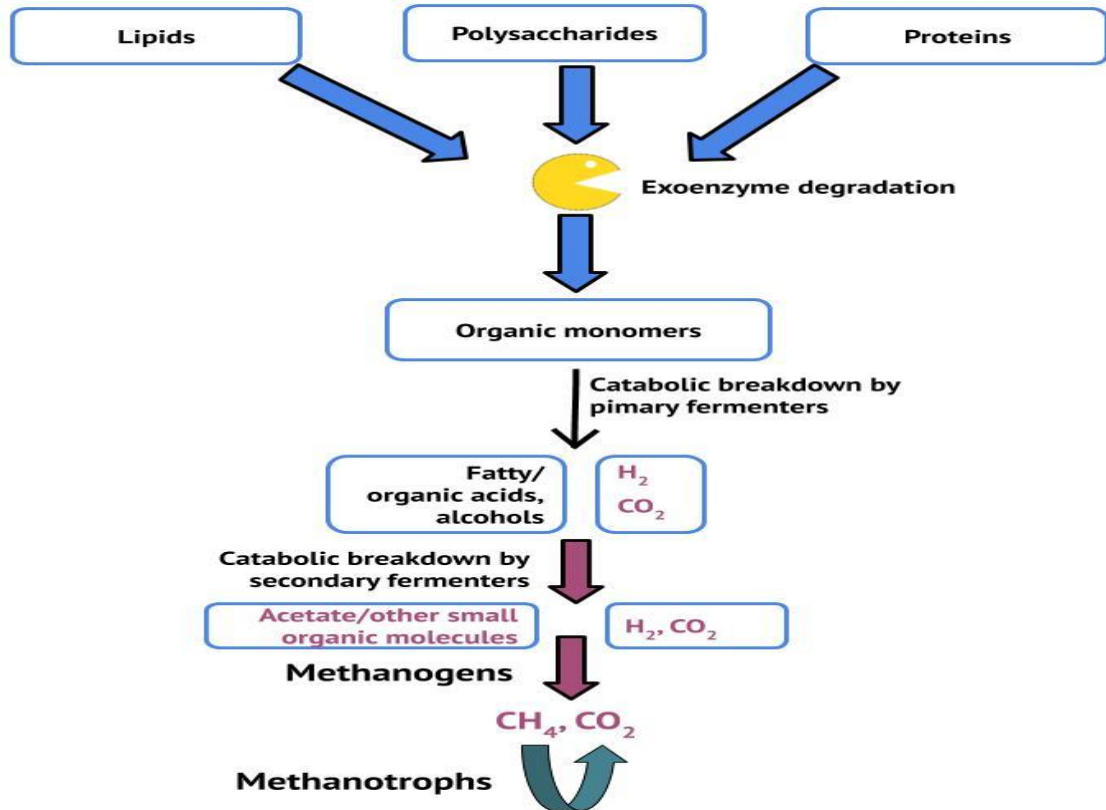
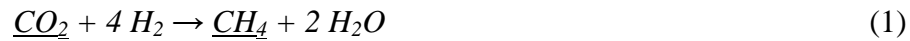

Figure 4: General methanogenesis pathways (Thauer, 1998).

Methanogenesis involves coenzymes and co-factors such as [F420](#), [coenzyme B](#), [coenzyme M](#), [methanofuran](#), and [methanopterin](#) (Finazzo *et al.*, 2003). The various steps of methanogenesis are shown in Fig 4. The first step is where the polymeric substrates are hydrolyzed to monomers by extracellular enzymes released by primary fermenters such as *Caldicellulosiruptor saccharolyticus* and other primary fermenters such as *Clostridium acetobutylicum* then convert the monomers to hydrogen, carbon dioxide, short-chain fatty acids and primary alcohols (Angelidaki *et al.*, 2011) in the process of acidogenesis. The secondary fermenters such as *Syntrophomonas wolfei* metabolize alcohols and fatty acids to hydrogen, carbon dioxide, and acetate during acetogenesis. Homoacetogenic bacteria and hydrogenotrophic methanogens (Angelidaki *et al.*, 2011) then capture the released hydrogen. The last process is where the acetoclastic methanogens such as *Methanosarcina barkeri* consume acetate and convert it to carbon dioxide and methane (Weiland, 2010). The four

main steps described above have to be fully tuned for the continuous yield of biogas (Nielsen *et al.*, 2009)

2.3.4 Protozoa

The importance of protozoans in sludge is well documented (Hirakata *et al.*, 2016; Hirakata *et al.*, 2020; Johnke *et al.*, 2014; Neto *et al.*, 2010), but there is still a need to learn more about the dynamics and role of the protozoans in methanogenesis as they interact with other organisms such as bacteria and archaea (Gilbride, 2005). Protozoans such as *Metopus* and *Caenomorpha* ciliates have been found to predate on the bacteria, increasing the methanogenic activities of granular sludge by 155% compared to those found in an up-flow anaerobic sludge blanket (UASB) reactor without the ciliates (Hirakata *et al.*, 2020). The effects of predation by protists in anaerobic systems have mostly been overlooked. Hirakata's (2020) results show that the influence of predation by protists needs to be examined and considered to understand the prokaryotic community structure and function in sludge (Seviour & Nielsen, 2010).

The dominant protozoans in the sludge include the *Cryptosporidium parvum*, whose cyst survives in sludge and the subsequent effluent chlorination (Fayer & Xiao, 2007). Cysts of flagellate protozoans such as the *Giardia lamblia* have also been successfully identified using molecular methods. However, they are readily removed from the effluents of the wastewater treatment plant (Seviour & Nielsen, 2010).

A study by Fenchel and Finlay (2010) found a symbiotic relationship between some species of methanogens and a few species of anaerobic ciliates, amoebae, and flagellates. These protozoans harbor methanogens and hence have unique organelles called hydrogenosomes. The relation between the host cells and their endosymbiotic methanogens is syntrophic hydrogen transfer; by removing the generated H₂, the methanogens stimulate host H₂-production, thus increasing the energetic yield of the energy metabolism. The Symbiotic methanogenesis of free-living anaerobic protozoa plays a modest quantitative role in CH₄ production in most habitats.

Ciliated protozoans exhibit numerical dominance in wastewater sludge, but they are highly affected by processes such as chlorination (Salvado *et al.*, 2001). A combination of the description of protozoans found in wastewater sludge is given in the manual of Foissner and Berger (1996) with free interactive software also developed in the Natural History Museum, London, to facilitate the identification of these protozoans (Seviour & Nielsen, 2010). However, how closely these descriptions relate to the ciliated protozoans in samples from other regions is not clear. Thus, this study will reduce the uncertainty surrounding the

protozoan biogeography against the available information in the gene banks and other databases.

2.3.5 Fungi

This group of microorganisms is viewed as unimportant members of the wastewater sludge community because of their low, competitive ability compared to bacteria (Jernkins *et al.*, 2004). The dominant fungi include the *Ascomycetes* and the *Basidiomycetes*. Predacious fungi, such as the *Zoophagus insidious* that consume rotifers, have also been identified in sludge (Seviour & Nielsen, 2010).

Detailed information on fungi in wastewater sludge and other aquatic environments in the tropics is scarce; especially those analyzed using culture-independent techniques (Lu *et al.*, 2006). However, Kambura *et al.* (2016) showed the ability of various groups of fungi to adapt to extreme environments, a finding expected in anaerobic digesters of sludge in WWTPs. Studies focusing on bacteria suggest that such work is likely to be revealing, especially with municipal WWTPs, where the well-known ability of fungi to degrade complex substrates may provide them with more advantages (Seviour & Nielsen, 2010). This may also be extrapolated to explain the role of fungi in methanogenesis, whose information is not well known.

2.4 Methanogenic genes in microorganisms

Even though methanogens are defined and unified as a group by the process of methanogenesis, they are diverse with the SSU rRNA sequences, which may indicate diversity in the group (Deppenmeier *et al.*, 1996). The methanogens have genomic DNAs that range from 23 to 61 mol % G + C, which may have bacillary, spiral, or coccal morphologies with different cell envelope structures (Reeve, 1992).

The methanogens employ elements of the same biochemistry to synthesize methane (Deppenmeier *et al.*, 1996). These microbes produce methane-using substrates like H₂/CO₂, acetate, formate, methanol, and methylamines catalyzed by different enzymes and coenzymes. There are three main pathways to methanogenesis: hydrogenotrophic, acetoclastic, and methylotrophic (Fig.5). In Acetoclastic methanogenesis, acetate is activated to acetyl-CoA by the action of acetate kinase or activity of acetyl-CoA synthetase (Dyksma *et al.*, 2020). The acetyl-CoA molecule is then dismutated using the enzyme acetyl-CoA decarbonylase, where the carbonyl group is oxidized to carbon dioxide while the methyl group is reduced to methane (Kurth *et al.*, 2020). Methylotrophic methanogenesis utilizes methanol and methylated amines as substrates. The methyl group is transferred to the corrinoid protein by the methyltransferase. The corrinoid protein is then channeled through

the methanogenic pathways in the methyl-CoM stage, where they are finally reduced to methane (Kurth *et al.*, 2020).

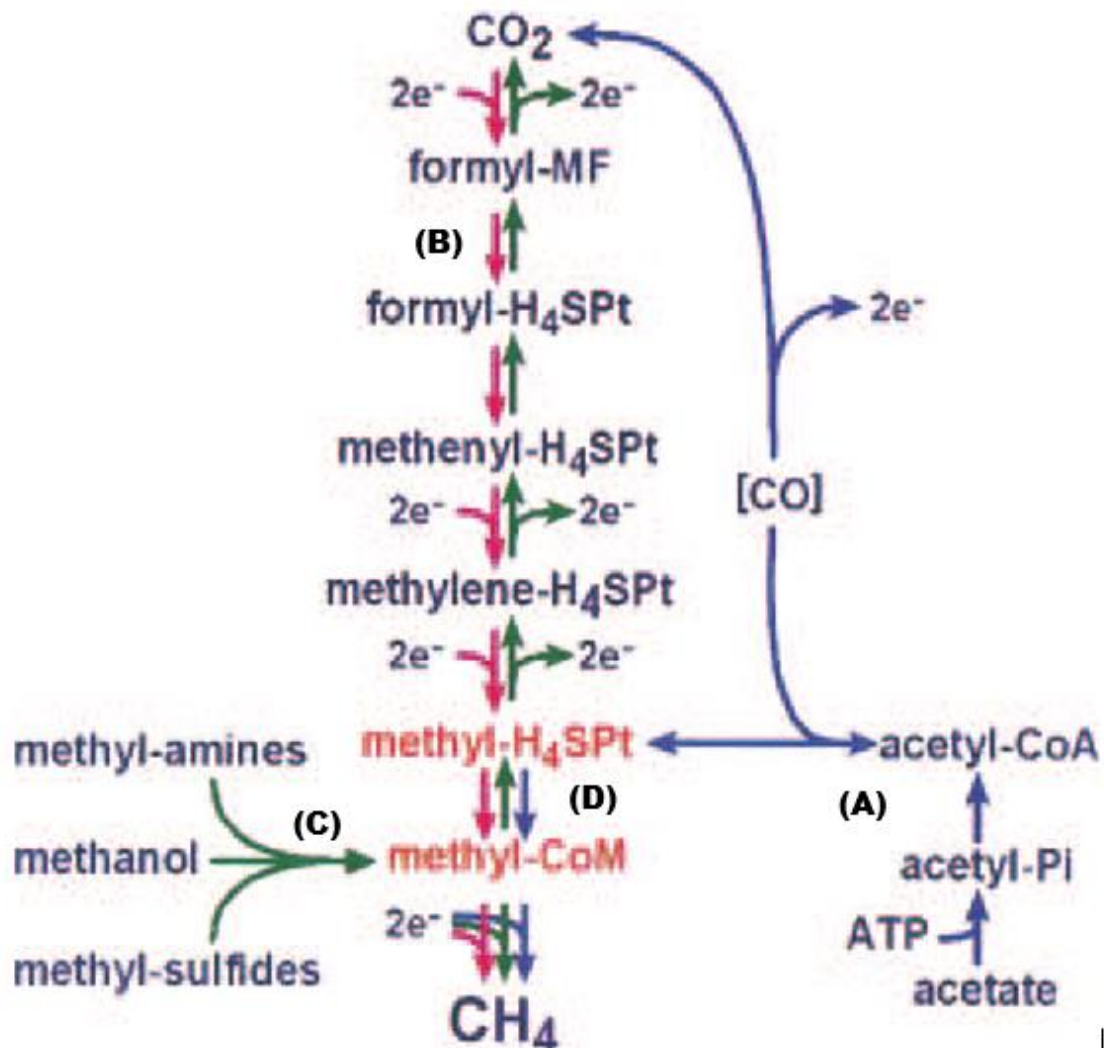

Figure 5: Three pathways for methanogenesis namely (A) acetoclastic pathway, (B) hydrogenotrophic pathway, (C) methylotrophic pathway and (D) the final stage of methane production. Methanogenesis is a form of anaerobic respiration using a variety of one-carbon (C-1) compounds or acetic acid as a terminal electron acceptor. All three pathways converge on the reduction of methyl-CoM to methane (Galagan *et al.*, 2022).

The hydrogenotrophic methanogenesis uses the H₂/CO₂ substrate where the CO₂ binds to methanofuran, and it is broken down to formyl-methanofuran in the presence of H₂. This process is catalyzed by the enzyme formyl-methanofuran dehydrogenase (Sun *et al.*, 2018). The formal part of formyl-methanofuran is transferred to coenzyme tetrahydromethanopterin forming formyl-tetrahydromethanopterin catalyzed by enzyme formyl transferase (Sun *et al.*, 2018). The formyl-tetrahydro-methanofuran is broken down to methyl-tetrahydromethanopterin catalyzed by coenzyme F₄₂₀. A methyltransferase-catalyzed

reaction allows the methyl group of methyl-tetrahydromethanopterin to be transferred to coenzyme M (Sun *et al.*, 2018).

The final step of methane production involves methyl-coenzyme M reductase and two coenzymes: N-7 mercapto heptanoyl threonine phosphate (HS-HTP) and coenzyme E_{430} (Cohen, 2014).

2.5 Physicochemical factors affecting methanogenesis

Methanogens tolerate a wide range of physicochemical conditions, for example, temperature ranges of -2 to 122 °C, pH values of 3.0 to 10.2, and salinities of up to halite saturation (Chen *et al.*, 2020). Variations in methane emissions can be mainly explained by variations in temperature (Hoehler *et al.*, 2018). The rates of methanogens increase more steeply with temperature, with the most tolerating temperature from -2 to 122 °C (Chen *et al.*, 2020). Temperatures for cell growth in psychrophilic and psychrotolerant methanogens range from -2 to 54°C (Ramirez *et al.*, 2018). Thermophilic and hyperthermophilic methanogens have a growth optimum of 105°C at 40 MPa and can grow at 122 to 431 °C (Hoehler *et al.*, 2018).

It is important to note that before the absolute physicochemical tolerances of methanogens are exceeded, methanogens may be affected (limited) by community-level factors that disrupt syntrophic interactions (Agnew & Leonard, 2003). For example, the anaerobic conditions to complete the decomposition of complex organics require collective activities of diverse methanogens catalyzing individual steps, and therefore methanogenesis depends on syntrophic partner organisms (Hoehler *et al.*, 2018). When considering the competition for common substrates among the methanogens, the presence of oxidants such as NO_3^- , Mn^{4+} , Fe^{3+} , and SO_4^{2-} can limit methanogenesis. Mn^{4+} and Fe^{3+} usually present in insoluble forms and may be unavailable for methanogens that depend on dissolved forms; therefore, such organisms depend on Mn^{4+} and Fe^{3+} to lower the concentrations of common substrates, an energetic advantage may be limited (Bretz & Whalen, 2014). In systems with high concentrations of nitrates and low concentrations of sulfates, such as agricultural waste sludge tanks, nitrate may be an essential factor for methanogens exclusion (Hoehler *et al.*, 2018).

Significant changes in pH can adversely affect cellular biochemistry and therefore affect methanogenesis. Environments with higher or lower than biochemically tolerable pH values are feasible because the lipid bilayer membrane is an effective barrier to ionic species like H^+ , OH^- or CO_3^{2-} (Hoehler *et al.*, 2018). Conversion of methanogenic substrates into

predominantly ionic forms that cannot diffuse across the cell membrane requires more energy or increased membrane permeability. Increased membrane permeability increases pH leakage and, therefore, limits methanogenesis in alkaline environments. This may be due to the deprotonation of acetic and carbonic acid, but also crucial for the methanogenic consumption of methylamines due to its protonation in acidic environments (Hoehler *et al.*, 2018).

Where possible, most developing countries like Kenya use a conventional process for water treatment due to high turbidity and color and the presence of colloidal matter (Ramirez *et al.*, 2018). The processes include; screening and pumping, grit removal, primary settling, aeration / activated sludge, secondary settling, filtration, disinfection, and oxygen uptake (Richter, 2001). For seven years, Ramirez *et al.* (2018) investigated moisture content, density, and total solids for several wastewater sludges. They found that these factors in the wastewater sludge presented similar characteristics to those of the drinking water sludge. The average moisture for most tropical wastewater sludge has been found to range between 74 to 76% average moisture content and 24 to 26% of total solids (Tartari, 2008). This is considered satisfactory because it allows for the mechanical dehydration of the sludge (Richter, 2001).

The density of wet sludge averages between 1.061 to 1.189 g/cm³ for centrifuged sludge with 25% total solids (Ramirez *et al.*, 2018). Sludge found in tropical areas has an alkaline characteristic with a hydrogen potential of between 6.7 to 7.9 (Tafarel *et al.*, 2016).

Due to products such as aluminium polychloride, ferrous sulfate, and sodium aluminate, there might be high amounts of heavy metals in sludge that affect its composition (Ramirez *et al.*, 2018). A temperature ranging from 0 to 50° C has been recorded in sludge, especially where there is the release of volatile compounds and degradation of organic compounds (Gastaldini *et al.*, 2015).

2.6 Methods of characterization of microbial methanogens

There is a wide range of well-elaborated methods used to analyze microbial methanogenic activities (Heyer *et al.*, 2015). Microscopic analysis of microorganisms, gene characterization, protein, metabolites analysis, and mRNAs are some of the methods used (Grotenhuis *et al.*, 1991). These methods have different targets and hence do not only provide the function and metabolic activity of individual species of microorganisms but also give details on the taxonomic composition and spatial organization of microorganisms in the sludge (Heyer *et al.*, 2015).

Microscopy, for example, is a common method for analyzing the abundance and distribution of microorganisms in space (Grotenhuis *et al.*, 1991). The limitation of

microscopy is that most microorganisms cannot be classified by morphology alone (Heyer *et al.*, 2015). Dobbernack *et al.* (1988) improved microscopy in a study that used the F420 cofactor involved in methanogenesis as a marker allowing septic detection of hydrogenotrophic methanogens.

To enable further differentiation, specific fluorescence methods such as fluorescence *in situ* hybridization (FISH) are used (Nettmann *et al.*, 2010). The only disadvantage is that sample impurities such as humic and fulvic acid may form a strong background fluorescence that interferes with the staining procedures (Senesi *et al.*, 1989).

Another widely applied method is flow cytometry, which discriminates between individual species in the presence of dynamic microbial communities (Dhoble *et al.*, 2016). However, a more robust and precise method for phylogenetic and functional characterization is the mRNAs or the molecular biological analysis of genes (Ziganshin *et al.*, 2016). The presence of the 16S rRNA genes is used for phylogenetic studies, while the corresponding mRNA is used to measure the functional diversity of the microorganisms (Heyer *et al.*, 2015). The mRNA is a good indicator of gene expression because of its low stability; RNA analysis requires a previously reversed transcription to the cDNAs (Dhoble *et al.*, 2016).

The DNA is usually amplified using polymerase chain reaction (PCR) with primers specific to the selected functional genes (Heyer *et al.*, 2015). Later, the PCR products, which must be equal in size, are separated by denaturing gradient gel electrophoresis (DGGE) or a terminal restriction frequent length polymorphism (TRFL), revealing the fingerprint, or the Next-generation sequencing (NGS) method can be used (Heyer *et al.*, 2015).

Where the 16S rRNA based community analysis is applied, identification of individual microorganism can be made by a clone library where the actual community profile can be generated by normalization with the abundance of the specific 16S rRNA gene (Klappenbach *et al.*, 2001) in the case of bacteria and archaeal domains.

Other methods, such as the Illumina sequencing and the 454 pyrosequencing, enable the assembly of the whole metagenome of microbial communities to give a snapshot of actual gene expression (Heyer *et al.*, 2015). It is important to note that the final metabolic activity is determined by the concentrations of proteins, among other factors, and hence the abundance of the microbial enzymes and proteins (Wilmes & Bond, 2006).

Recently, microbiome research has moved from 16S rRNA gene sequencing to more comprehensive functional representations via whole genome or shotgun metagenomics sequencing (Pyzik *et al.*, 2018). This relatively new environmental sequencing approach is used to examine thousands of microorganisms in parallel and comprehensively sample all

genes, providing insight into community biodiversity and function. Shotgun sequencing allows for detecting low abundance members of microbial communities (Giwa *et al.*, 2019).

Studies on microorganisms involved in the general biogas production have been done, but the bacteria specifically involved have not been fully documented. Therefore the various bacterial samples in biogas production plants are still unknown and unclassified (Kröber *et al.*, 2009). One study in Kenya (Murunga *et al.*, 2016) only focused on culturing and isolating methanogenic microorganisms in different sludge environments ignoring the possibilities of the uncultured bacteria in the sludge microorganisms' community.

This study focused on identifying high potential methane-producing bacteria from wastewater sludge using a metagenomic rapid, reliable, and economic molecular genetic approach without isolation and culturing of bacteria. This favors diverse groups of potential methanogenic bacteria in sludge. Sequence-based analysis of metagenomic sequences using the MG-RAST pipeline was applied. This provided an opportunity to explore the metabolic potential of complex communities. The advantage of the approach is that metagenomics data also enables simultaneous identification of the functions and microorganisms responsible for specific processes (Mitchell *et al.*, 2018).

CHAPTER THREE

MATERIALS AND METHODS

3.1 The study site

Nyeri Water and Sanitation Company Limited is one of the best performing, and well-managed ISO/IEC certified sewerage treatment plants in Kenya (Kariunga *et al.*, 2018). The study site, Kangemi Sewage Treatment Works, is near the Chania River at 0°25'S, 36°58"E in Kangemi ward, Nyeri County. The area receives equatorial rainfall due to its location. The long rains occur from March to May while the short rains falls from October to December although sometimes this pattern is occasionally disrupted by abrupt and adverse changes in climatic conditions (Orodho, 2001). The annual rainfall ranges from 500mm in dry areas of Kieni plateau to 1,500mm in the Aberdare hills and areas around Mt. Kenya. The climate contains temperatures ranging from of an annual minimum of 12° C to a mean of 27° C (Kariunga *et al.*, 2018). It is situated 4 kilometers from the Nyeri town center and was commissioned in 1988 (NYEWASCO, 2007). The plant is accessible and has well-maintained wastewater treatment processes with a high potential for methane production (Orodho, 2001). The wastewater treatment plant has a capacity of over 50,000 m³ per day. It serves a population of approximately 36500 people. It is equipped with Infill Sewers of sizes between 225mm to 300mm and a total length of approximately 20,000 meters, including the constructed manholes. It has a desludging tank that receives sludge from the wastewater treatment process and regulates sludge flow to the lagoons. It also has four lagoons that serve as sludge tank digesters where the sludge stays for four months before being released to the dry beds. It has fourteen dry beds where the sludge is dried. It is then released to farmers for agricultural land application (NYEWASCO, 2007).

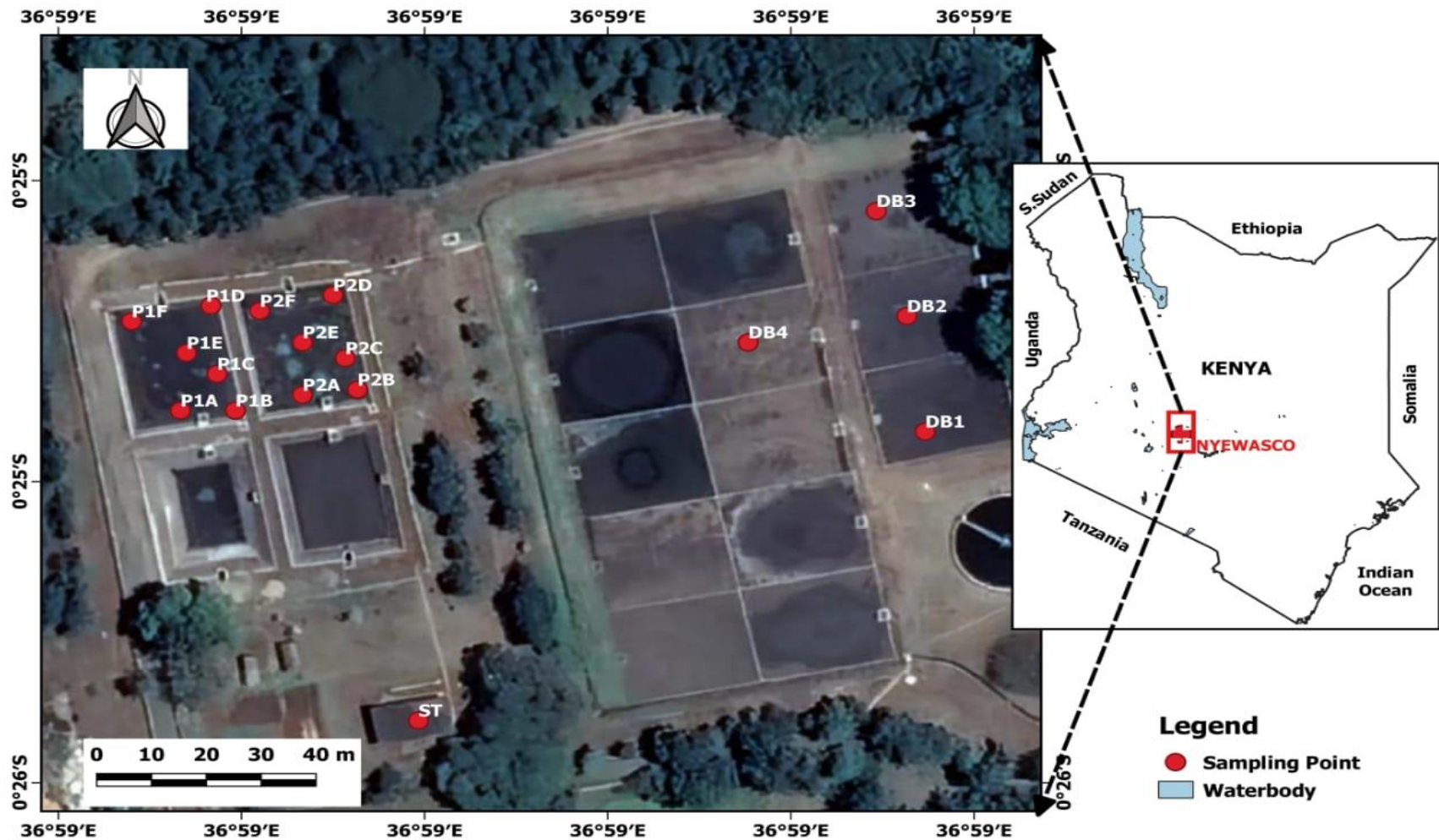

Figure 6: A Satellite Map of Kenya showing location of Kangemi WWTP and the sampled sites (Inset: map of Kenya). Source: (ILRI dataset) - Map Created with QGIS (courtesy of Kariunga Saed, MSc Limnology Egerton University Student, 2021)

3.2 Sampling sites

Sampling was done between September to December, 2022 at the NYEWASCO-Kangemi WWTP at selected sites on different sampling occasions within three months. The geographical position of each site in terms of latitude, longitude, and elevation was taken using the Global Positioning System called the GARMIN eTrex 20.

Some of the safety precaution measures taken during sampling included using safety goggles to protect the eyes, protective face masks to protect the mouth and nose from wet sludge splashes, liquid repellent coveralls to keep off sludge from clothing, rubber boots and water proof gloves to prevent exposure to sewage sludge. After sampling, thorough cleaning was done using 0.05% chlorine for contaminated clothes and antibacterial soap for showering and hand washing.

The zigzag sampling design was used where samples were taken between 0-30 cm deep at random. Samples were taken in triplicates per point to capture the spatial variability of the sampling parameters. The samples collected were from the sludge well, lagoon 1 (Pond 1), lagoon 2 (Pond 2), Dry bed 1 (DB1), Dry Bed 2 (DB2), Dry Bed 3 (DB3), and Dry Bed 4 (DB4) located in the treatment plant (see fig. 7). The two lagoons were selected because they were the only two operational at the time of sampling and showed activity of active methane production. Lagoon 1 was two weeks old, while lagoon 2 was four months old ready to be drained to the dry beds. From lagoon 1 (Pond 1) and Lagoon 2 (Pond 2), samples were collected six different times and made into five composite samples, each with a DNA shield in the ratio of 1:1.

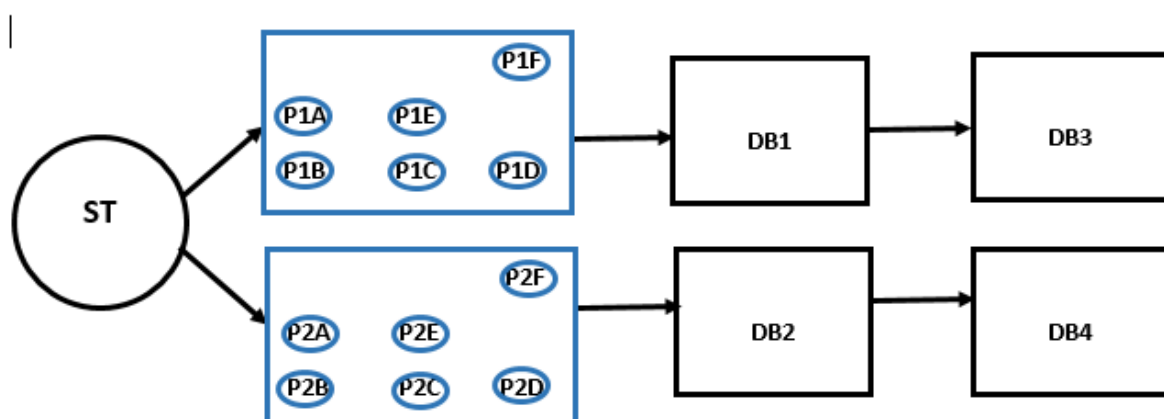

Figure 7: Schematic diagram showing the sampling points

The sampling point ST was situated at the sludge well, where all the sludge from the treatment plant is received and then pumped to the different lagoons (see plate 1a). The sampling points Pond 1 and Pond 2 are lagoons around 25 meters high where the sludge is retained for three to four months (see plate one a-c). The ponds/lagoons are in the decomposition phase, where the methanogens and other microbes are expected to be active. DB1, DB2, DB3, and DB4 are the dry beds receiving ‘treated’ sludge through underground pipes from the lagoons (Plate 1d and 2e, f, g, h). These dry beds are fitted with concrete slabs with spacing between them to allow the water in sludge to percolate underground and the sludge to dry for three months before they are sold to farmers as manure.



Plate 1: Photographs showing (a) the sludge tank or well, (b) Sludge digestion lagoon-P1 (C) Sludge digestion lagoon-P2 and (d) sludge drying beds located at NYEWASCO-Kangemi WWTP



Plate 2: Photographs Showing (e) Sampled Drying Bed 1, (f) Sampled Drying Bed 2, (g) Sampled Drying Bed 3 and (f) Sampled Drying Bed 4 located at NYEWASCO-Kangemi WWTP

3.2.1 Sampling and field measurements

The Physico-chemical measurements of pH, Temperatures, and dissolved oxygen were taken *in-situ* using calibrated portable multi-meters (HACH, hq40d model) in the sludge digestion lagoons, i.e., Lagoon 1 and Lagoon 2. During the sampling period, sludge samples

for determination of total solids (TS), volatile solids (VS), total carbon, total organic matter, nitrogen (N), phosphorus (P), bulk density, porosity, texture, water content, electrical conductivity (EC), Zn, Mg, Mn, Ca, K, Cu, Fe, and Na analyses were collected using 500 ml acid-washed plastic bottles from each sampling point. The samples were then stored in a cool box at 4°C and transported to Egerton university soil laboratory for further analysis. Sludge physical-chemical properties analysis was then done using standard methods for wastewater (APHA, 2005), as briefly described in the appropriate subsection below.

The samples for DNA analyses were collected from the active sludge digestion lagoons 1 and 2. Thus, grab samples were collected from six sampling points, each using a 2.5 litre container that was acid washed and rinsed with sterile water. The samples were then composited in one sterile bucket and mixed well using the acid-washed and sterilized shovel. Then 5ml of the composites were collected into 10ml sterile cryogenic tubes fitted with a cap. This was done for both sludge digestion lagoons 1 and 2. After that, 5ml of the DNA/RNA shield was added to each of the samples to preserve the nucleic acids at ambient temperature and inactivate microorganisms. The samples were stored in a cool box under ice, transported to the Marker-Assisted Selection Laboratory of the Kenya Agricultural and Livestock Research Organisation (KALRO), Njoro, and stored at -20°C before DNA extraction.

3.2.2 Determination of physicochemical properties of NYEWASCO-Kangemi WWTP

a. pH and Electrical Conductivity measurements in the laboratory

The electrical conductivity (EC) was determined using a conductivity meter with a conductivity bridge (Model CM-1 Mark V) for the sludge. A suspension of sludge in water (1:1) was prepared and filtered through a Buchner funnel. The filtrate was transferred into a 50 ml beaker and a conductivity probe was used to check the EC reading (Okalebo *et al.*, 2002). The pH was determined using a pH-meter (a digital ion analyzer) according to the procedure described by Okalebo *et al.* (2002).

b. Total and Volatile Solids determination

Total solids

The sample (25g) was placed on an evaporating dish covered with a watch glass and weighed to the nearest 0.01. The weight (W) was recorded for each sample. Each sample was then spread so that it was evenly distributed across the evaporating dish. The samples were then evaporated to dryness in a steam bath before being dried at 105°C for 12 hours. After drying, samples were placed in a desiccator to cool and before weighing. The residue was then heated at 105°C for 1 hour, cooled to balance the temperature in a desiccator, and weighed again. The heating, cooling, desiccating, and weighing procedures were repeated

until the weight change was less than 4%. The final weight was then recorded as W total. Total solids were then determined by the formula (APHA, 1998) thus;

$$Total\ solids\ (\%) = \frac{(W_{total}-W_{dish}) \times 100}{(W_{sample}-W_{dish})} \dots\dots\dots Equation\ (3)$$

Where W total = Weight of dish (g) + dry sample

Wdish = weight of dish (g)

Wsample = Weight of dried residue and dish (g)

Volatile Solids

The evaporating dishes containing the dried residues from the total solids section were transferred to a cool muffle furnace and ignited for 2 hours at 550°C. The residue was then cooled in a desiccator to balance the temperature and weighed. Igniting (30 min), cooling, desiccating, and weighing steps were repeated until the weight change was less than 4%. The final weight as "W_{volatile}." Volatile solids were then determined by the formula (APHA, 1998);

$$Volatile\ solid\ \% = \frac{W_{total}-W_{volatile}}{W_{total}-W_{dish}} \times 100\% \dots\dots\dots Equation\ 4$$

Where Wdish =Weight of dish

Wtotal = Weight of the dried residue and dish

Wvolatile =Weight of the residue and dish after ignition

c. Gravimetric water content determination

The air-dried sludge was weighed, dried at 105 °C for 24 hours, and then weighed at room temperature. The percentage differences in the two masses before and after drying were determined as the measure of the water content as described in the Wilke method (Sliz & Wilk, 2020)

d. Determination of sludge particle size

This was done using the hydrometer method where sludge is air-dried, then sieved through 75 μ sieve. A portion of 50g of the air-dried sludge was mixed with 250 ml of distilled water and 50 ml Kalgon solution and homogenized for 10 minutes. The solution was then made to 1litre and measurements taken using a hydrometer. The particle size was then calculated as described by Bedaiwy (2012). The hydrometer measures the specific gravity of the soil suspension at the centre of its bulb. The specific gravity depends upon the mass of solids present, which in turn depends upon the particle size.

e. Determination of bulk density

Bulk Density is the dry weight of sludge per unit volume of sludge. It is expressed as the dry weight of sludge divided by its volume in g/cm^3 (Verheijen *et al.*, 2019). The samples in this study were processed according to the method in Okalebo *et al.* (2002). A core ring of 5 cm diameter with initial known weight (W_1) and volume (V) was filled to the brim with sludge. The samples were then removed and placed in an oven at 105°C for 48 hours after which they were allowed to cool before weighing (W_2),

The bulk density was then calculated as follows:

$$\text{Bulk density (g cm}^{-3}\text{)} = (W_2 \text{ (g)} - W_1 \text{ (g)})/V \text{ (cm}^3\text{)} \quad \text{Equation 4}$$

Where, W_1 was the weight of the core and W_2 was the weight of the dried sample in the core and V was the volume of the core.

f. Mechanical analysis of sludge texture

A sample of air-dried sludge weighing 50 g placed in a cup was saturated with half-full distilled water and 10 ml of Calgon solution (10%) added before stirring the cup contents for 10 minutes. The suspension was transferred to a Bouyoucos cylinder and filled to the mark with distilled water. The suspension was stirred using a plunger for eight (8) minutes and a hydrometer was placed in the suspension. The hydrometer reading was taken after 40 seconds and the temperature of the suspension was measured with a thermometer. The cylinder was then allowed to stand undisturbed for 2 hours, after which both the hydrometer and the temperature reading were taken. The hydrometer was then calibrated at 20°C and hence, for every degree above 20°C , 0.2 was subtracted and for every degree below 20°C , 0.2 was added to correct the hydrometer reading as described in Okalebo *et al.* (2002).

The soil, clay, and silt distributions were then measured, and the sludge was assigned the texture class using the textural triangle (Yang *et al.*, 2015).

g. Total organic carbon determination by the Walkley-Black method

Total Organic Carbon (TOC) was determined by heating about 50 g of the air-dried sludge in a muffle furnace for 30 minutes at 250°C . The weight loss was then determined by heating the sludge further for 4 hours at 560°C . The mineral matter content expressed in percentage(%) was then determined by subtracting the total organic carbon (%) from 100% (Mannoubi, 2021).

h. Organic nitrogen and phosphorous determination

(i) Total phosphorus

Total Phosphorous was determined using the total phosphorus soil analysis method as described in APHA (1998). The phosphorus in sludge was extracted with 0.5M Sodium hydrogen carbonate solution at pH 8.5, a reagent that controls the removal of calcium phosphate (Sims, 2000). Phosphorus in solution, derived from calcium and iron phosphate, was determined colorimetrically as a blue phosphomolybdic complex reduced by a mixed reagent comprising of sulphuric acid, ammonium molybdate, ascorbic acid and potassium antimonyl tartrate (Watanabe & Olsen, 1965).

(ii) Nitrogen (Kjeldahl)

Total Kjeldahl Nitrogen was determined by the Kjeldahl method as described in APHA (1998). The organic nitrogen compound in the dried sludge sample was digested with concentrated sulphuric acid and selenium mixture as a catalyst. Nitrogen is converted to ammonium sulphate in the process. The digest was then made alkaline by mixing with Sodium Hydroxide. Ammonia gas released in the process was distilled off and collected in boric acid and titrated against the standard solution (Bremner, 1960).

i. Determination of mineral elements

The mineral elements viz; Na, Ca, Mg, Fe, Zn, Cu, Mn, Pb, Cu and K were also determined from sludge samples. The determination of these elements in the substrate was done using the double acid method of extraction as described in Okalebo *et al.* (2002). The AAS was used for the estimation of these available elements in the tested substrate.

3.3 Molecular characterization of microorganisms

The extractions of DNA from the sludge samples were carried out at the Marker Assisted Selection Laboratory of the Agricultural and Livestock Research Organization (KALRO)Njoro. Samples were preserved in DNA/RNA Shield and stored at -20°C prior to extraction. Thereafter extraction was done using ZymoBIOMICS DNA extraction kit as per the manufacturer's instruction with a slight modification. The modification involved incubating the sample at -20°C for 12 hours after adding the genomic lysis buffer to maximise DNA recovery.

3.3.1 DNA extraction

DNA was extracted using the commercially available ZymoBIOMICS™ DNA Miniprep Kit (Zymo Research) designed to extract DNA from a wide array of sample inputs including sewage sludge, which is immediately ready for metagenomics analyses. Extraction was done according to Kong *et al.* (2013). The quality of the extracted DNA was analysed

using Nanodrop 2000c Spectrophotometer (Thermo, USA) to determine the concentration and purity of the DNA to ensure the recommended minimum DNA concentration of 10 ng/ μ L and purity level of optical density (OD) 260/280 above 1.8. The OD_{260/280}>1.8 was attained (Giwa *et al.*, 2019) (table 1). The total extracted DNA was then stored in PCR tubes and transported on ice to Inqaba Biotechnical Industries (Pty) Ltd (South Africa) for whole-genome shotgun metagenomics analysis.

Table 1: Concentration and purity of the total extracted DNA from the samples collected at Nyeri-Kangemi wastewater treatment plant.

Composite sample name	Nano drop 260/280 ratio (Purity)	Concentration (ng/ μ L)
Sample 1b	1.82	75.2
Sample 1c	1.83	62.1
Sample 2a	1.86	26.4
Sample 2c	1.91	28.4

3.3.2 Whole-genome shotgun metagenomics method

At Inqaba Biotech Industries laboratory, genomic DNA samples were fragmented using an enzymatic approach with help of NEB Ultra II FS kit. Resulting DNA fragments were size selected (>200 base pairs), using AMPure XP beads. The fragments were end repaired and Illumina specific adapter sequences were ligated to each fragment. Each sample was individually indexed, and a second size selection step was performed. Samples were then quantified, using a fluorometric method with NEBNext Library Quant Kit for Illumina, diluted to a standard concentration (4nM) and then sequenced on Illumina's NextSeq platform, using a NextSeq mid out kit (300 cycle), following a standard protocol as described by the manufacturer. 1Gb of data (2x150bp paired-end reads) were produced for each sample (Campanaro *et al.*, 2016).

Table 2: Metagenome data reads for lagoon 1 and lagoon 2

Sampling site	Metagenome code name (Forward)	Metagenome code name (Reverse)	First Sequencing lanes	Barcodes	Second sequencing lanes
Lagoon 1	KA-1b	KA-1b	D712	AGCGATAG	D505
Lagoon 1	KA-1c	KA-1c	D712	AGCGATAG	D506
Lagoon 2	KA-2a	KA-2a	D712	AGCGATAG	D507
Lagoon 2	KA-2c	KA-2c	D712	AGCGATAG	D508

3.4 Data analysis

3.4.1 Analysis of Physicochemical properties data

The data for EC, DO, Temperature, Oxidation-Reduction Potential (ORP), pH, Total solids (TS), volatile solids (VS), sludge bulk density, moisture content, texture, particle density, total organic phosphorus (TOP), total organic carbon (TOC), total organic nitrogen (ON), and Total Organic Matter (TOM) in lagoon 1, together with data for Calcium (Ca), Sodium (Na), Potassium (K), Magnesium (Mg), Manganese (Mn), Zinc (Zn), Iron (Fe) and Copper (Cu) in the raw and dry sludge were analysed using Student's t-test to compare means and find out if there was significant difference between lagoon 1 and lagoon 2 and between the raw and the dry sludge. Prior to the analyses, data was subjected to normality and homogeneity of variance tests.

In the lagoons, the Temperature, pH, EC, DO and ORP passed the normality test and were subjected to t-test while the data for TS, VS, sludge bulk density, moisture content, texture, particle density, TOP, TOC, ON, and TOM failed the normality test and were subjected to non- parametric Mann-Whitney U test. In the raw and dry sludge, the data for TS, sludge bulk density, particle density, pH, EC, and TOP passed the Shapiro-Wilk normality test and were subjected to t-test. The data for volatile solids (VS), temperature, total organic carbon (TOC), total organic nitrogen (ON), porosity, sludge moisture content, sludge texture, Calcium (Ca), Sodium (Na), Potassium (K), Magnesium (Mg), Manganese (Mn), Zinc (Zn), Iron (Fe) and Copper (Cu) failed the normality test and was subjected to non- parametric Mann-Whitney U test.

The tests were done at a significance level of 0.05 ($p < 0.05$). Where the P-value was less than 0.05 meant that, the differences between means of each of the parameters in the two lagoons were statistically significant. Therefore, we reject the hypothesis 1. Where $P > 0.05$,

we accept hypothesis 1. The physical chemical parameters were analysed using R vegan; a statistical analysis software. Composite samples data were analysed using descriptive data analysis where the means and standard deviation of the parameters in the sludge tank (sludge inlet) and the dry bed (sludge outlet) were calculated in Microsoft Excel spreadsheets and presented in tables.

The collected data on the density of microbes (bacteria, archaea, eukaryotes and methanogens) from the four (4) composite samples were computed to find the mean densities at for each of the samples. ANOVA was then used in comparing the means of these densities. Data was subjected to a normality and homogeneity of variance tests and all tests were carried out at $p < 0.05$ significance level. The mean values of the different samples were tested using the Kruskal-Wallis test (ANOVA on ranks). This nonparametric test was chosen because of the skewness and heterogeneity of the variances of most variables. To find out if there was any significant difference between the four (4) samples, the significant means of microbial densities in ANOVA test were separated using the Dunn's as the Post Hoc test.

3.4.2 Analysis of whole-genome shotgun metagenome sequencing data

a. Sequencing *data quality control and pre-sequencing analysis*

The shotgun sequencing data was pre-processed by using SolexaQA (Cox *et al.*, 2010) to trim low-quality regions from FASTA data. Bases from low quality DNA were removed from the 3' and 5' ends. Bases were removed if the average quality is below 15 bps. Platform-specific approaches were used for illumina data submitted in FASTA format: reads more than two standard deviations away from the mean read length were discarded as recommended by Huse *et al.* (2007). A dereplication step was performed using a simple k-mer approach to rapidly identify all 20-character prefix identical sequences. This was to remove artificial duplicate reads (ADRs) (Alvarez *et al.*, 2009). The ADRs were then set aside to be used for error estimation.

DRISEE (Duplicate Read Inferred Sequencing Error Estimation) (Keegan *et al.*, 2012) was used to analyze the sets of ADRs and determine the degree of variation among prefix-identical sequences derived from the same template as described by Alvarez *et al.* (2009). Screening was then done using a fast, memory-efficient, short read aligner called Bowtie to remove all reads similar to the human genome and render them inaccessible (Langmead *et al.* 2009). Technical replicates were identified by binning reads with identical first 50 base-pairs. One copy of each 50-base-pair identical bin was retained. The FASTA formatted file 150.dereplication.passed.fna contained the sequences were retained and passed on to the next stage of the analysis pipeline

b. General phylogenetic analysis

A prediction server (MG-RAST) for metagenomics computational annotation of non-assembled DNA was applied to determine taxonomic diversity. This was done by annotating the metagenomics sequences obtained against the RefSeq database using the MG-RAST pipeline (Giwa *et al.*, 2019). Sludge community taxonomic profiles were carried out through identification of similar sequences in reference databases; NCBI (The National Centre for Biotechnology Information) with the use of the MG-RAST pipeline (Pyzik *et al.*, 2018). Alpha diversity was calculated in MG-RAST where the Shannon-Wiener diversity index was calculated as abundance-weighted average of the logarithm of the relative abundances of annotated species. The species richness was computed as the antilog of the Shannon diversity:

$$\text{Richness} = 10^{-\sum p_i \log(p_i)} \quad \text{Equation 5}$$

Where P_i are the proportions of annotations in each of the species categories

Other indices of diversity were also used; Taxa richness (S) obtained is the total number of species in the community, where relative abundances $p = (p_1, \dots, p_S)$ (Tuomisto, 2010). Where p_1 is the first individual and p_S is the number of the last individual.

Dominance was obtained through the following formula:

$D = \sum p_i^2$ (Simpson, 1949), where p_i is the proportion of individuals found in species i . For a finite community, this is:

$$D = \sum n_i (n_i - 1) / (N (N - 1)) \quad \text{Equation 6}$$

Simpson diversity index is derived from the dominance where it is obtained via the following formula: $1-D$ (or sometimes $1/D$ or $-\ln D$) (Simpson, 1949).

Shannon-Wiener index (H') most commonly used index in ecological studies values range from 0 to 5, calculated: $H_{Sh} = -\sum P_i \ln(P_i)$ where H_{Sh} is the Shannon diversity index, p_i is the proportion of individuals found in species i and $\ln =$ the natural log (Shannon, 1948).

Evenness was obtained $J = H_{Sh} / H^*_{Sh}$, where H^*_{Sh} is the maximum value of H_{Sh} (a function of S) (Tuomisto, 2010).

To assess the compositional similarity among sludge samples from different microbial communities, the Bray-Curtis measure of beta diversity (Xu *et al.*, 2014) was employed to compare all pairwise taxonomic abundances between each sample using R vegan; an open source statistical analysis software (Roopnarain *et al.*, 2017).

c. Methanogen phylogenetic analysis

Methanogenic specific phylogenetic characterization was achieved by HMM search of methanogenic related sequences in the MG-RAST analysis platform by focusing on genes

encoding to (1) methyl CoM reductase (*mcr*) responsible for final methane release; (2) formyl methanofuran dehydrogenase (*fmd*) that releases CO₂; (3) dehydrogenase/acetyl-CoA synthase (*cdh*) that releases acetate; (4) methyl transferase (*mta*) that releases methanol and (5) the methylamine methyl transferase (*mtm*, *mtb*, *mtt*) that release fatty acids: all involved in the methanogenesis process. The methanogenic taxonomy was obtained by phylogenetic tree placement of the best-obtained hits (Pyzik *et al.*, 2018).

The methanogenic organism's compositional similarity from the different sampling sites were comparatively assessed using the Bray-Curtis measure of beta diversity (Xu *et al.*, 2014) which compared all pairwise taxonomic abundances between each sample using R vegan; a statistical analysis software.

d. Phylogenetic trees for the methanogenesis pathways

The evolutionary analyses were conducted in MEGA 11 (Tamura *et al.*, 2021). The evolutionary history was inferred using maximum Parsimony method. The metagenomics pathway trees were obtained using the Subtree-Pruning-Regrafting with search level 1 in which the initial trees were obtained by the random addition of sequences (10 replicates) (SPR) algorithm (Kumar *et al.*, 2000).

3.5 A summary of the methods used in the study

The flow diagram (Fig 8) gives the stepwise summary of this study from collection of samples in the sampling site at NYEWASCO and onsite physico-chemical data collection. It also summarises the laboratory analysis from DNA extraction to the subsequent shotgun metagenomics, bioinformatics and statistical comparative analysis of methanogens found.

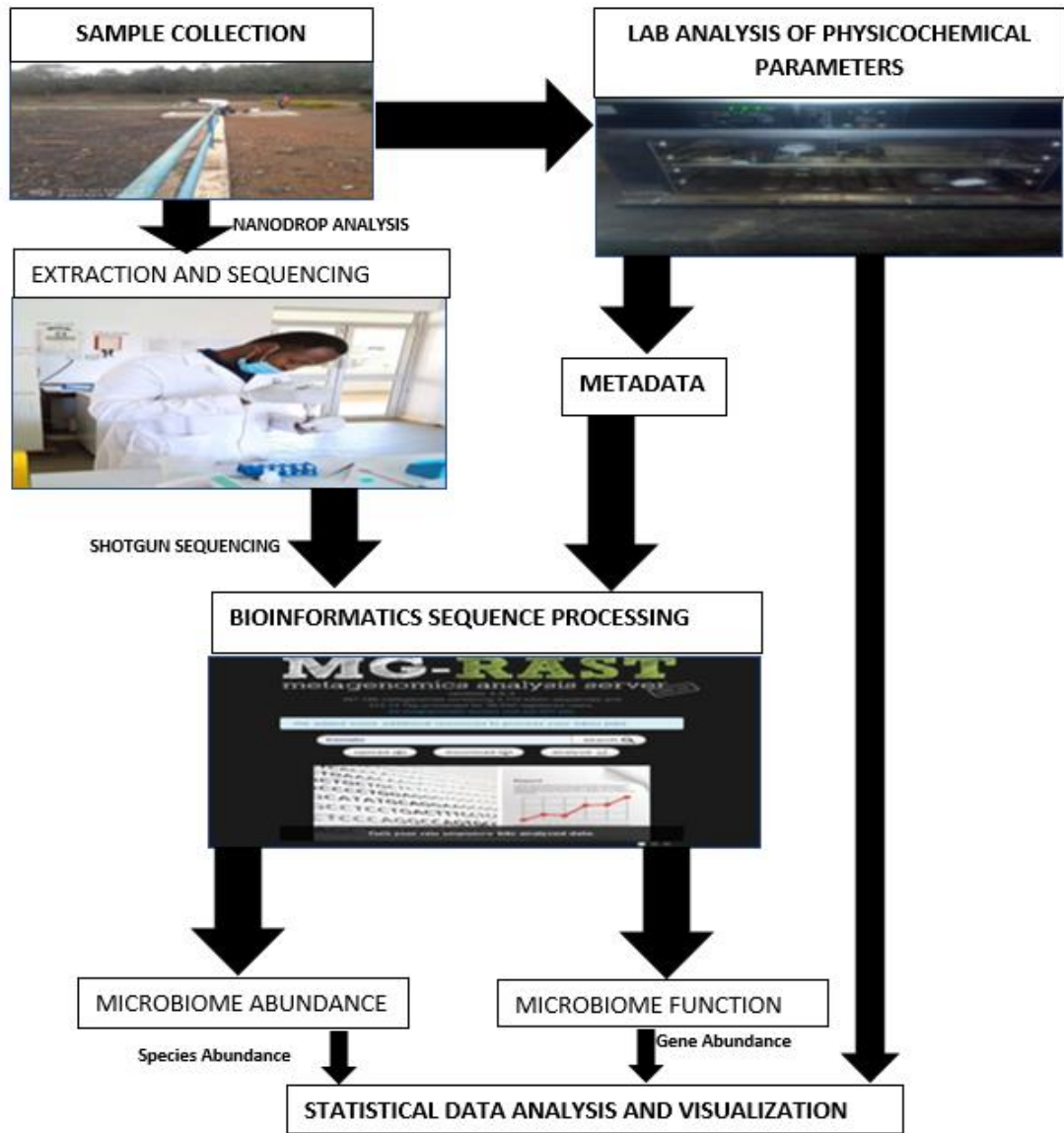

Figure 8: A flow diagram summarizing the materials and methods in this study.

3.6 Research authorization

Research authorization was obtained from National Commission for Science, Technology, and Innovation (NACOSTI) in Kenya (see Appendix E), and permission to research the wastewater treatment plant was obtained from Nyeri Water and Sanitation Company limited (see Appendix F).

CHAPTER FOUR

RESULTS

The results obtained and recorded in this study are described and sequentially presented in various sections of this chapter as follows;

4.1 Physicochemical properties of sludge

4.1.1 Physicochemical properties of sludge in the anaerobic sludge digestion tanks

Some of the physical chemical properties recorded *in-situ* at the sampling sites in the active anaerobic digesters at lagoon 1 and lagoon 2 of the Nyeri-Kangemi Wastewater Sewage Plant are shown in Table 3. The measured parameters included; temperature, pH, oxidation-reduction potential, dissolved oxygen and electrical conductivity.

A slightly higher temperature (24.910 ± 0.910 °C) was recorded in lagoon 2 (compared to temperature (24.360 ± 0.850 °C) in lagoon 1. The temperatures in the two lagoons were significantly different $t(34) = 1.821$, $p = 0.039$. There was no significant difference in the pH in lagoon 1 (7.340 ± 0.370) compared to lagoon 2 (7.350 ± 0.160), $t(34) = 0.099$, $p = 0.461$. The oxidation-reduction potential (ORP) in the two lagoons demonstrated anaerobic conditions as indicated by the negative values recorded. However the ORP measured in lagoon 1 (-56.289 ± 21.340 Mv) exhibited no significant difference compared to the ORP measured in lagoon 2 (-56.900 ± 0.380 Mv), $t(34) = 1.081$, $p = 0.542$.

Table 3: Means of physicochemical parameters collected *in situ* in the sludge digestion lagoons (mean (n) \pm standard deviation)

SITE	Temperature (°C)	pH	ORP (Mv)	DO (mg/l)	EC (mS/cm)
Lagoon 1	24.360 \pm 0.850	7.340-7.71	-56.289 \pm 21.340	0.192 \pm 0.097	2.370 \pm 1.200
lagoon 2	24.910 \pm 0.910	7.35-7.51	-56.900 \pm 0.380	0.220 \pm 0.180	1.650 \pm 0.200
P-value	0.039	0.461	0.542	0.264	0.214

As expected the dissolved oxygen concentration was very low in both lagoons indicating anaerobic conditions and possibly low aerobic microbial activities if any. There was no significant difference in the DO concentrations measured $t(34) = 0.644$, $p = 0.264$ despite lagoon 2 showing a slightly higher DO mean concentration of 0.220 ± 0.180 mg/L compared to lagoon 1 with DO concentration of 0.192 ± 0.097 mg/L. The EC in lagoon 1 (2.370 ± 1.20 Mv) was not significantly different compared to lagoon 2 (1.650 ± 0.200 Mv).

Both lagoon 1 and 2 recorded a moisture content of $98.05 \pm 0.151\%$ and 98.91 ± 0.218 respectively and above 90%. Bulk density, particle density and porosity in lagoon 1

were recorded as $0.040 \pm 0.005 \text{ g/cm}^3$, $1.030 \pm 0.012 \text{ g/cm}^3$, and $99.270 \pm 0.125\%$; and $0.010 \pm 0.008 \text{ g/cm}^3$, $1.010 \pm 0.008 \text{ g/cm}^3$, $98.910 \pm 0.218\%$ respectively in lagoon 2. Bulk density was significantly different ($P=0.0156$) in the two lagoons while particle density and porosity recorded no significance difference with p-value of 0.7184 and 0.6040 respectively. Total solids were significantly different ($P=0.0259$) with $11.600 \pm 0.036\%$ of recorded in lagoon 1 and $17.200 \pm 0.089\%$ in lagoon 2 while the volatile solids ($P=0.4143$) was not significantly different in lagoon 1 at $15.850 \pm 3.324\%$ and $15.880 \pm 0.237\%$ in lagoon 2 (see table 4) There was no significant difference in the moisture contents of the two lagoon with lagoon 1 recording value of $98.05 \pm 0.151\%$ and value of $98.91 \pm 0.218\%$

Table 4: Means and standard deviation of physico-chemical properties of composite samples analysed in the laboratory

Sample	Bulk density (g/cm)	Particle density (g/cm)	Porosity (%)	Total solid (%)	Volatile solid (%)	Moistur e (%)	Total Carbo n (%)	Total Organi c Matter (%)	Total Nitroge n (%)	Total Phosphoru s (mg/L)
Lagoon 1	0.04 ± 0.005	1.03 ± 0.012	99.27 ± 0.125	11.60 ± 0.036	15.85 ± 3.324	98.05 ± 0.151	1.07 ± 0.094	1.72 ± 0.002	0.17 ± 0.005	84.88 ± 0.943
Lagoon 2	0.01 ± 0.008	1.01 ± 0.008	98.91 ± 0.218	17.20 ± 0.089	15.88 ± 0.237	98.91 ± 0.218	0.24 ± 0.005	0.46 ± 0.040	0.14 ± 0.001	78.3 ± 0.005
P-Value	0.0156	0.7184	0.6040	0.0259	0.4143	0.6163	0.1240	0.0722	0.8183	0.9608

Total organic matter ($P=0.0722$), total organic carbon ($P=0.1240$), total nitrogen ($P=0.8183$) and total phosphorus ($P=0.9608$) were not significantly different in the two lagoons. Total organic matter was $1.720 \pm 0.002\%$ in lagoon 1 and, $0.460 \pm 0.040\%$ for Lagoon 2. total organic carbon was $1.070 \pm 0.094\%$ in lagoon 1 and $0.240 \pm 0.005\%$, in lagoon 2. Lagoon 1 recorded a value of $0.170 \pm 0.005\%$ of total nitrogen (TN) and a value of $0.140 \pm 0.001\%$ in lagoon 2. Total Phosphorus was at $84.880 \pm 0.943\text{mg/L}$ in lagoon 1 and of $78.300 \pm 0.005 \text{ mg/L}$ in lagoon 2.

4.1.2 A comparison of physico-chemical properties of sludge in the sludge tank (raw sludge) and dry beds (composted sludge) composite samples

Table 5 summarizes the selected physical properties of both raw sludge in the sludge tank/well and the by-product which is dried sludge found in the drying beds. The raw sludge temperature were not significantly different ($P = 0.0765$) even though a higher temperature of $23.13 \pm 0.15 \text{ }^\circ\text{C}$ was recorded at the source compared to the dried sludge $21.03 \pm 0.06^\circ\text{C}$. The bulk density increased significantly ($P = 0.0046$) through the treatment process from $0.14 \pm 0.03 \text{ g/cm}^3$ in the raw sewage to $0.24 \pm 0.02 \text{ g/cm}^3$ in the dry sludge, this can be attributed to the compactness due to dewatering which reduces pore spaces. The lower organic matter was low in dry sludge can also be attributed to increased bulk density (table 5). The particle density slightly decreased ($P = 0.6164$) from $2.33 \pm 0.15 \text{ g/cm}^3$ to $2.30 \pm 0.02 \text{ g/cm}^3$ in the dried sludge. The raw sludge had a total pore space of $94.4 \pm 0.01\%$ and decreased to $90.7 \pm 0.01\%$ in the dry beds but not significantly ($P = 0.0722$), nevertheless the moisture content in the raw sludge was $77 \pm 1.00\%$ compared to $11.3 \pm 0.700\%$ in the dry sludge but the difference was not significant ($P = 1.000$). The Total solids and the volatiles solids increased from $12.66 \pm 0.48\%$ to $53.40 \pm 8.82\%$ and $11.22 \pm 0.09\%$ to $29.79 \pm 9.94\%$ from raw sludge to dry sludge respectively. The Mann-Whitney test showed that TS were significantly different ($P = 0.0419$) while the VS were not significantly different ($P = 0.1033$) in the raw sludge compared to the dry composted sludge.

Table 5: Physicochemical properties of sludge tank and dry bed composite samples

PARAMETERS	Raw sludge	Dry sludge	P-Value
Temperature (°C)	23.13 ± 0.15	21.03 ± 0.06	0.0765
pH	5.53 - 5.72	6.52 - 6.79	0.0002
EC (mS/cm)	4.03 ± 0.05	3.77 ± 0.05	0.0020
Total Carbon (%)	2.47 ± 0.05	2.03 ± 0.05	0.0722
Total Organic Matter (%)	4.27 ± 0.05	3.42 ± 0.05	0.6338
Total Nitrogen (%)	0.20 ± 0.01	0.19 ± 0.01	0.1840
Total phosphorus (mg/l)	91.67 ± 1.25	88 ± 1.63	0.9653
bulk density (g/cm³)	0.14 ± 0.03	0.24 ± 0.02	0.0046
Particle density (g/cm³)	2.33 ± 0.15	2.30 ± 0.02	0.6163
Porosity (%)	94.4 ± 0.01	90.7 ± 0.01	0.722
Total solids (%)	12.66 ± 0.48	53.40 ± 8.82	0.0419
Volatile solids (%)	11.22 ± 0.09	29.792 ± 9.94	0.1033
Moisture (%)	77 ± 1.00	11.3 ± 0.70	1.000

Values are means ± SD*

It can be seen from Table 5, that the pH ranged from 5.53 to 6.52 from the raw sludge in the sludge tank and the dry sludge in the dry beds. The pH values recorded were lower and significantly different in the raw sludge compared to the dry sludge with P value of 0.0002. The electrical conductivity recorded was 4.03 ± 0.05 mS/cm in the raw sludge and dropped significantly (P = 0.002) to 3.77 ± 0.05 mS/cm in dry sludge. This can be attributed to the drop in temperature recorded in the dry sludge and reduction of dissolved solids as evidence by reduction of TN and TOP in dry sludge. The total organic carbon showed no significant difference with the raw sludge recording values of 2.47 ± 0.05% while dry sludge recorded the values of 2.03±0.05%. The total organic matter was not significantly different (P = 0.6338) with 4.27 ± 0.05% recorded in raw sludge and 3.42 ± 0.05% in the dried sludge. The total organic nitrogen was not significantly different (p=0.1840) in the two type of sludge as evidenced by more or less similar concentrations with values of 0.20 ± 0.01% in the raw sludge and 0.19 ± 0.01% in the dry sludge. The total organic phosphorus was 91.67 ± 1.25 mg/l in the raw sludge well and 88 ± 1.63 mg/l in the dry beds but recorded no significant difference between the two.

Table 6 sums up the metal concentrations in both the sludge tanks sample (raw sludge) and the dry beds (dry sludge). Calcium recorded the highest concentration of 48.59 ±

0.62 mg/l in the sludge tank followed by potassium and sodium at of 21.96 ± 0.04 mg/l and 21.96 ± 0.04 mg/l respectively. Copper and Zinc had the lowest concentrations of 0.04 ± 0.03 mg/l and 0.04 ± 0.01 mg/l. In the dry bed samples, the metals iron, copper, zinc and manganese increased significantly with the highest concentration recorded for iron at 1896.18 ± 106.20 mg/l while the lowest concentration recorded was that of copper with a concentration of 5.65 ± 0.12 mg/l (see table 6). Despite all the metals showing no significant difference between the raw and the dry sludge, the above selected metals recorded higher concentrations in the dry sludge than in the raw sludge.

In the raw sludge, Zinc and copper were within the permissible limits as set by the Environmental Management and Coordination (EMCA) on Water Quality Regulations (2006) while the rest of the tested metals exceeded the set standards. In the dry bed samples, it was only copper that was within the set permissible limit while zinc, manganese and iron were above the set limits and therefore harmful to the receiving water bodies.

Table 6: Concentration of selected metals (Means \pm SD)

Metal	P (mg/L)	K (mg/L)	Ca (mg/L)	Mg (mg/L)	Na (mg/L)	Fe (mg/L)	Cu(mg/L)	Zn (mg/L)	Mn (mg/L)
Sludge Tank	10 \pm 1.25	21.96 \pm 0.04	48.59 \pm 0.62	16.58 \pm 0.06	21.96 \pm 0.04	1.645 \pm 0.28	0.035 \pm 0.03	0.04 \pm 0.01	0.475 \pm 0.09
Dry Beds	800 \pm 38.85	114.38 \pm 4.81	266.42 \pm 27.55	190.52 \pm 4.82	84.61 \pm 0.71	1896.175 \pm 106.20	5.645 \pm 0.12	39.175 \pm 0.36	139.3 \pm 0.29
Permissible limits (EMCA, 2006)	2	-	-	-	-	1	80	2	1
P- value	0.1678	0.9506	0.3333	0.2593	0.2343	0.9997	0.7366	0.0733	0.0986

The sludge textural characteristics as it can be seen from table 7, both raw and dry sludges were mainly of a sandy texture with sand particles constituting 98% in both cases and with a paltry 2 % of clay. Thus, there was no significance difference in the texture between the raw and dry sludge (P=0.1236).

Table 7: The raw and dried sludge texture

SAMPLE	Sludge Texture (g/L)	Sand (%)	Clay (%)	Silt (%)	Textual Class
Raw sludge	1.33 ± 0.47	98	2	0	Sandy
Dry sludge	1.67 ± 0.47	98	2	0	Sandy

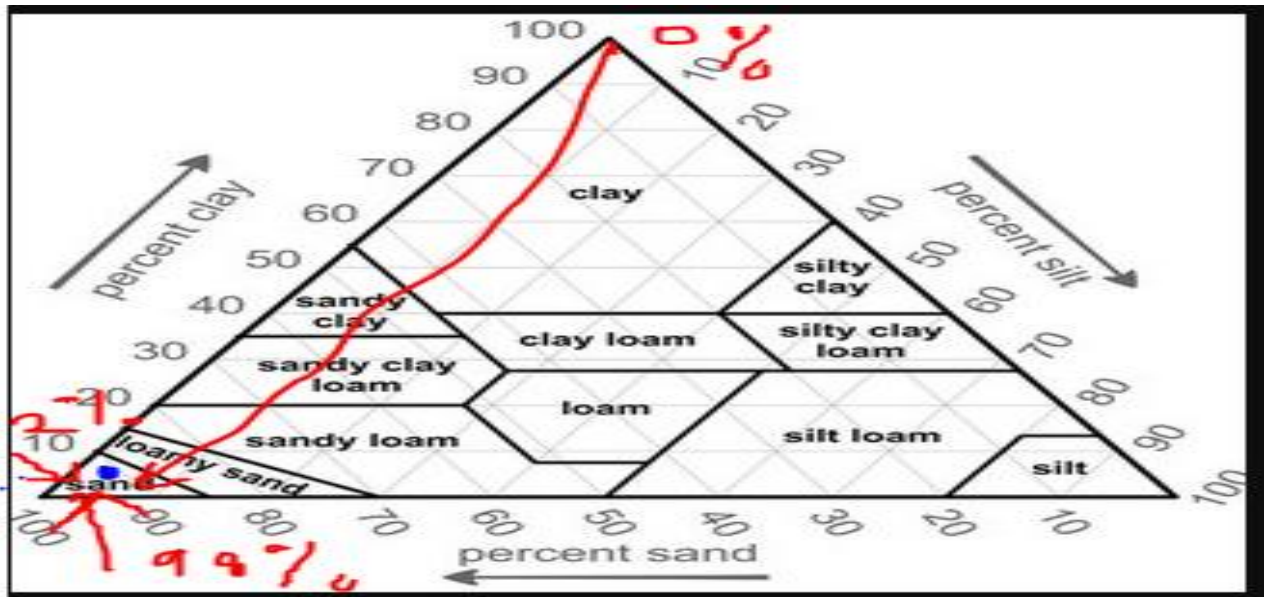

Figure 9: The textural triangle diagram for classification of sludge (Groenendyk *et al.*, 2015).

4.2 Microbiological parameters

4.2.1 The Shotgun metagenomics data sets of microbial community in this study

Samples were analysed using shotgun sequencing metagenomics method. The dataset obtained contained an average 2,592,135 sequences. The base pairs for the four samples averaged 310,112,079 base pairs with an average length of 157 bps. Of the sequences tested, an average of 76,647 sequences failed to pass the quality control (QC) pipeline. The high quality reads averaged 1,979,866.25 sequences while the low quality reads averaged 181,490 sequences. The total duplicate read inferred sequencing error estimation (DRISEE) of lagoon 1b, 1c, 2a, and 2c metagenomes were 1.602%, 3.310%, 3.310%, and 3.339% respectively.

The K-mer curve (Fig.10) generated by the MG-RAST pipeline indicated sequence datasets obtained that can support inferences about genome size and coverage in this study. The most abundant sequences reported the highest coverage of 10^3 . The shotgun datasets in this study produced roughly equal proportions of the A, T, G and C base calls with no vertical bars or patterns as visualized by the nucleotide histogram (Fig. 11). This meant that the data set had no contamination by artificial sequences and that there were no untrimmed contiguous barcodes and therefore the biological information contained in the reads are intact (not consumed by the untrimmed barcodes).

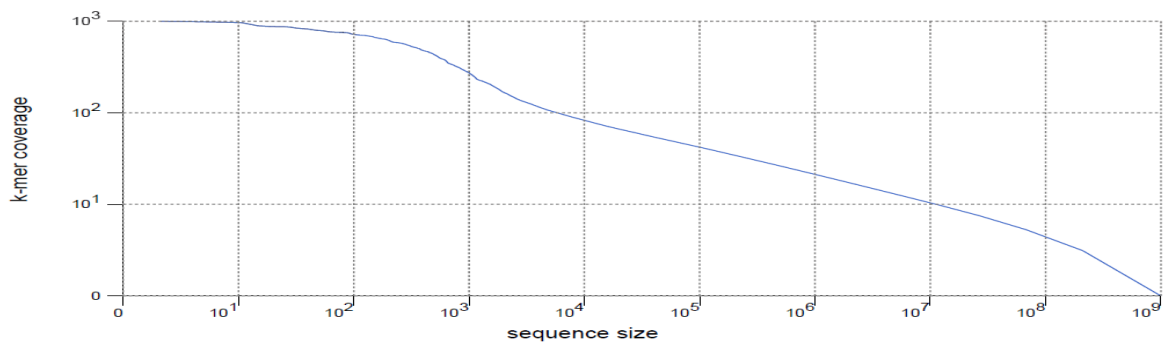

Figure 10: The k-mer rank abundance graph plotting the k-mer coverage as a function of abundance rank, with the most abundant sequences

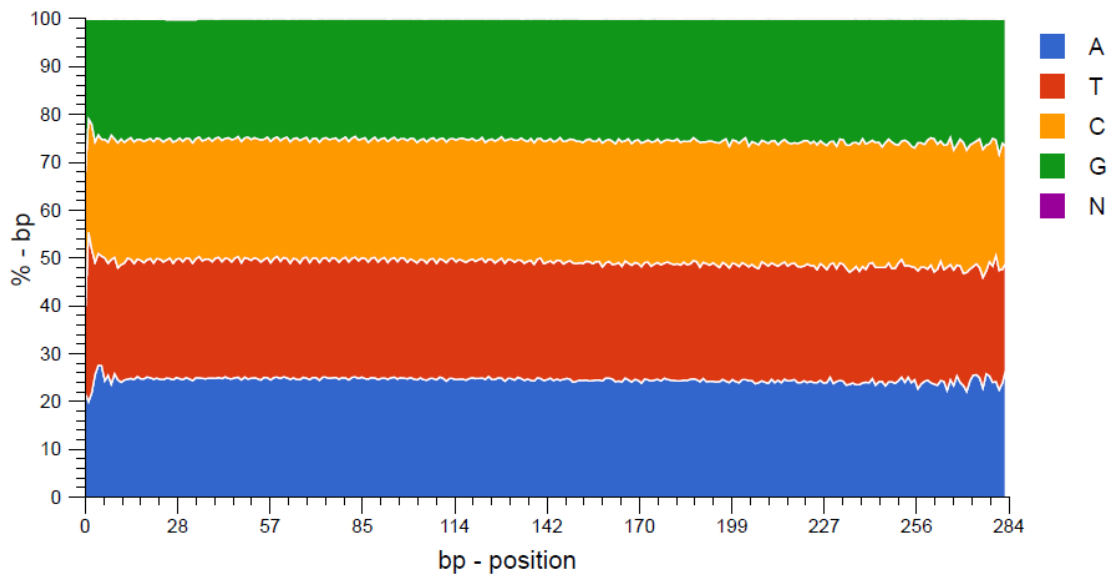

Figure 11: This graph shows the fraction of base pairs of each type (A, C, G, T, or ambiguous base N) at each position

The MG-RAST pipeline uses different data bases to run the hits. These databases included a stable reference for genome annotation, gene identification and characterization data base known as Reference sequence database (RefSeq), a database of molecular functions

represented in terms of functional orthologs called the KO database, and a database used for predicting gene functions and discovering new pathways called the SEED subsystems among others as shown in appendix D.

4.2.2 Sequenced data quality metrics

The FASTA formatted file 150.dereplication.removed.fna contained the sequences that were rejected and not passed on to the next stage of the analysis pipeline. The following table contains the number of reads mapped to the references for each sample.

Table 8: Sequence quality metrics per sample

SITE	SAMPL E	TOTAL READS	FAILED READS	HQ READS	LQ READS
Lagoon 1	1b 1c	3,007,248 2,755,482	66,461 (2.21%) 108,996 (3.96%)	2,720,234 (90.46%) 2,396,775 (86.98%)	220,553 (7.33%) 249,711 (9.06%)
Lagoon 2	2a 2c	919,642 2,269,642	48,473 (5.27%) 82,659 (3.64%)	781,755 (85.01%) 2,020,701 (89.03%)	89,414 (9.72%) 166,282 (7.33%)

Where; Total Reads= Total number of sequence reads analyzed for each sample.

LQ Reads=: Number (percentage) of low quality reads.

HQ Reads=: Number (percentage) of high quality reads used for further analysis.

4.2.3 Taxonomic profiling

After screening and removing host sequence reads, non-host reads were subjected to taxonomic profiling algorithm using MG-RAST and the RefSeq genomes reference database. The final classified and un-classified reads are reported in table 9 while the number of reads assigned to each kingdom is reported in table 10.

Table 8: Taxonomic profiling metrics per sample

SITE	SAMPL E	TOTAL READS	CLASSIFIED READS	UNCLASSIFIED READS
Lagoon 1	1b	3,007,248	2,720,234 (90.46%)	287,014 (9.54%)
	1c	2,755,482	2,396,775 (86.98%)	358,707 (13.02%)
Lagoon 2	2a	919,642	781,755 (85.01%)	137,887 (14.99%)
	2c	2,269,642	2,020,701 (89.03%)	248,941 (10.97%)

Table 9: Number of reads assigned to different kingdoms for samples from lagoons 1 and 2

SITE KINGDOM	Lagoon 1		Lagoon 2	
	1b	1c	2a	2c
Bacteria	865,103	977,515	225,291	592,525
Archaea	(92.33%)	(93.41%)	(91.13%)	(91.63%)
Eukaryotes	66,912 (7.14%)	63,073 (6.03%)	20,305 (8.21%)	49,799 (7.70%)
Viruses	3,782 (0.40%)	4,293 (0.41%)	938 (0.38%)	2,496 (0.39%)
Unclassified sequences	763 (0.08%)	842 (0.08%)	406 (0.16%)	1,111 (0.17%)
Other sequences	420 (0.04%)	711 (0.07%)	276 (0.11%)	664 (0.10%)
	17 (0.00%)	29 (0.00%)	10 (0.00%)	27 (0.00%)

Eukaryotes=: Fungi, Parasitic and non-parasitic Protozoa.

4.2.4 Taxa abundance

Abundance measured by the percentage of OTUs assigned reads from various taxonomic levels were determined. The metagenomic classification of bacteria, archaea and eukaryote found in the digestion lagoons are summarized graphically in interactive Krona plots (Fig12, 13 & 14). The measured taxonomic abundance at phylum levels for Bacteria, Achaea and Eukarya domains across the samples are presented in stacked bar plots. The highest taxa abundance were recorded in lagoon 1(sample 1b and 1c) with over 28 phyla in each sample collected. Sample 1c recorded over 1,600,000 hits of species while sample 1b recording 1,500,000 hits. Samples 2c recorded 1,000,000 total hits while sample 2a recorded 400,000 hits only (Fig.15A).

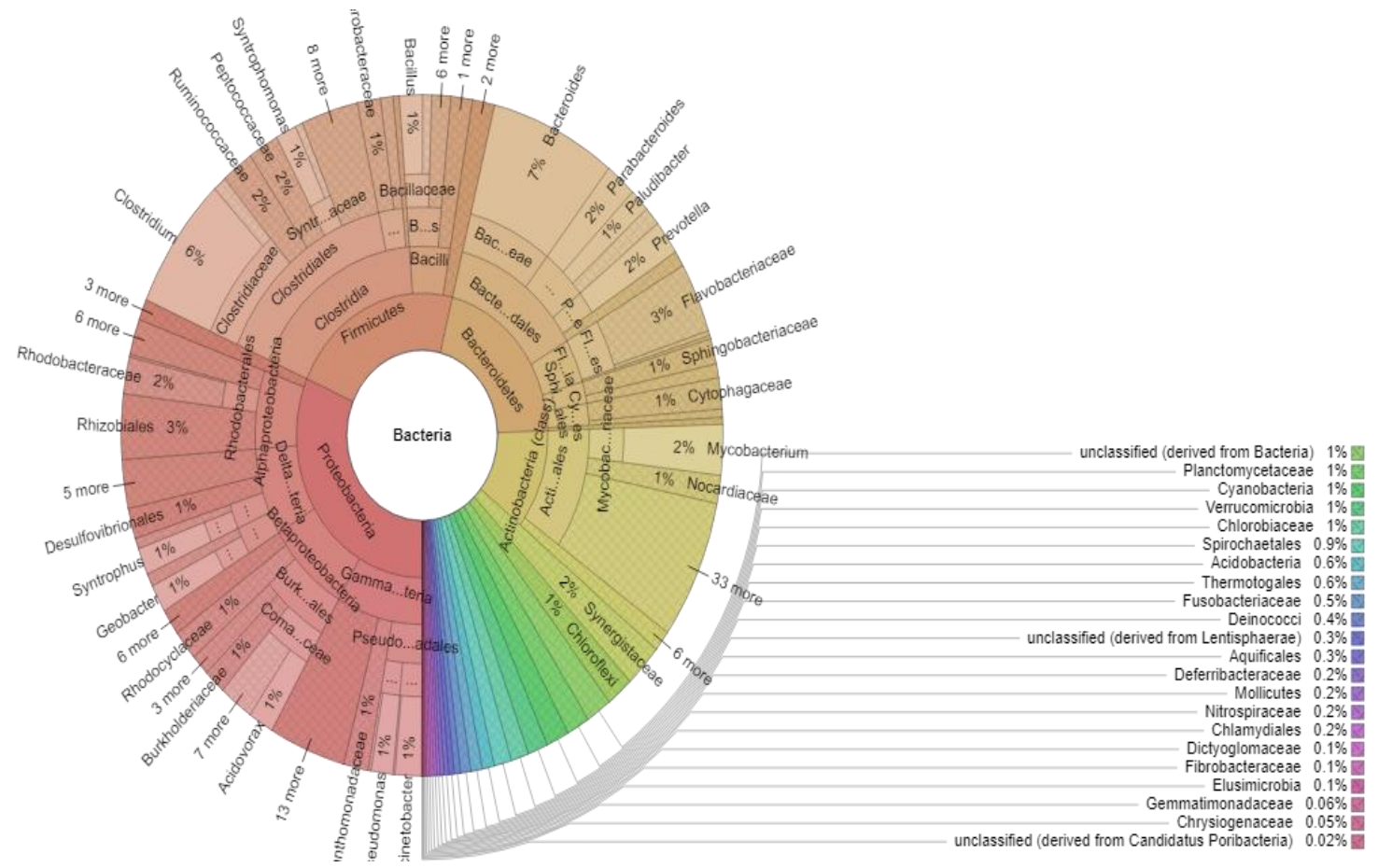

Figure 12: An interactive plot generated by Krona on the different hierarchies of metagenomics classification of bacteria in lagoon 1 and 2

Among the Archaea domain, five (phyla) were represented in these lagoons with the highest taxonomic abundance recorded in lagoon 1 with sample 1c and 1b recording equal number of hits of 100,000. Sample 2c recorded 80,000 hits while sample 2a recorded 38,000 hits of Archaeal species (fig. 15B).

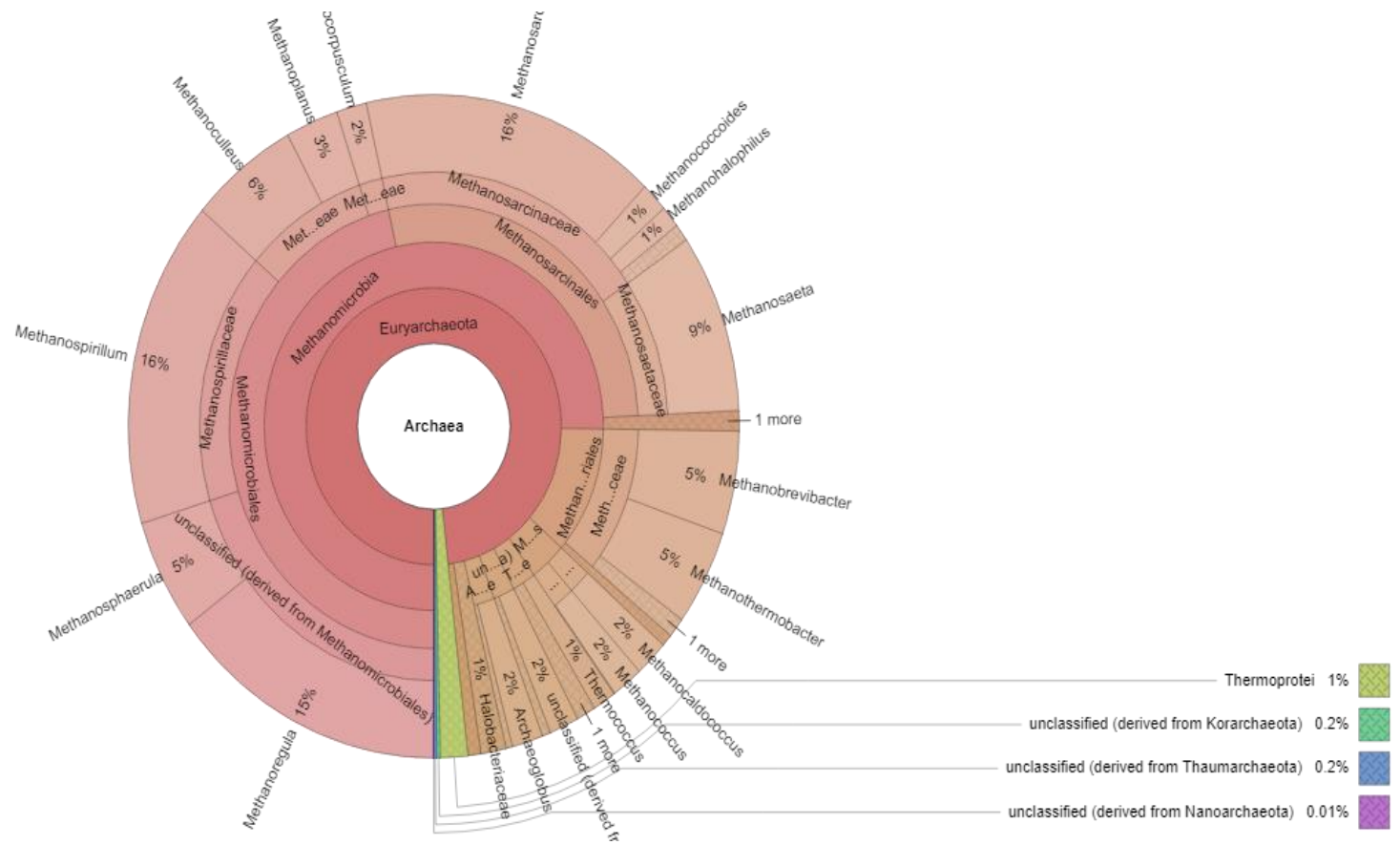

Figure 13: An interactive plot generated by Krona on the different hierarchies of metagenomics classification of Archaea in lagoon 1 and 2

The Eukaryotes which included majorly the fungi, parasitic and non-parasitic protozoans were represented by 24 phyla. Lagoon 1 recorded the highest number of taxa abundance with sample 1b recording 15,000 hits, and sample 1c recording 9,800 hits. Sample 2c recorded 7,500 hits while sample 2a recorded only 3,500 hits of eukaryotic species (see fig.15C). The eukaryotic metagenomic classification is summarized in fig. 14.

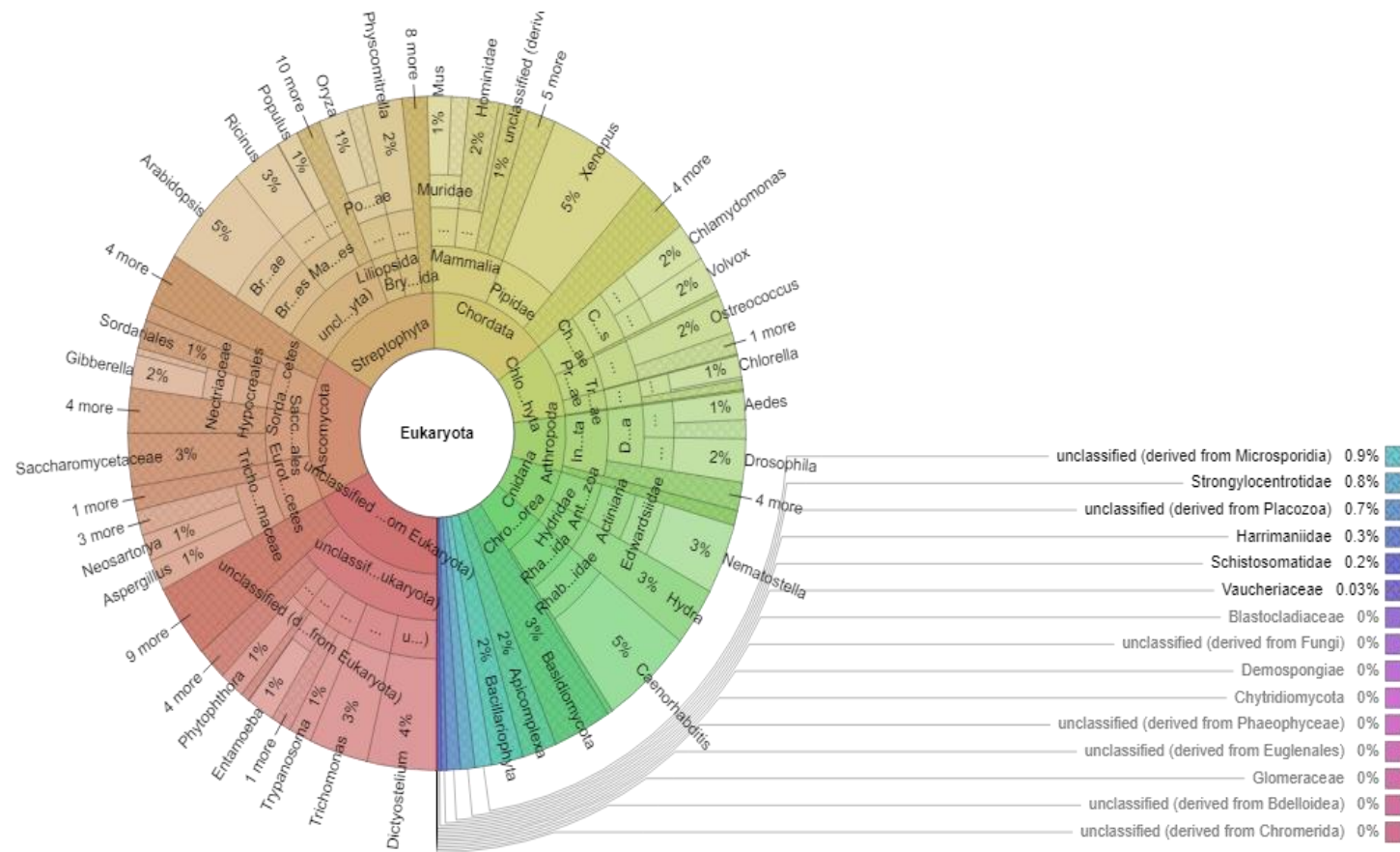
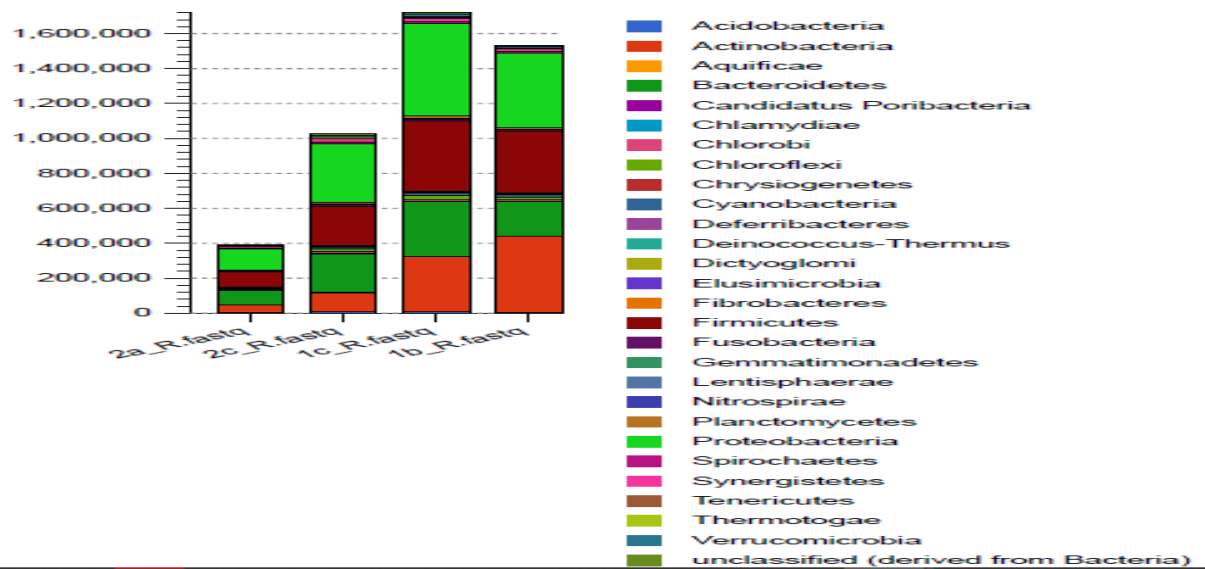
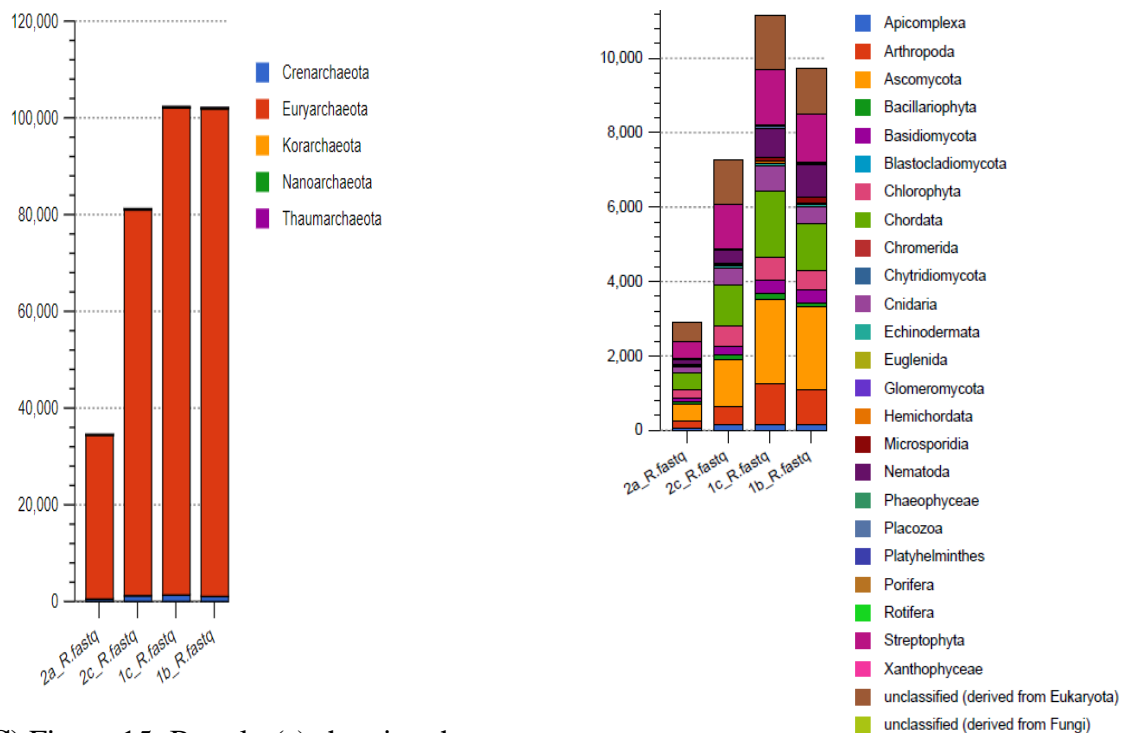

Figure 14: An interactive plot generated by Krona on the different hierarchies of metagenomics classification of Eukaryote in lagoon 1 and 2

(A)



(B)



(C) Figure 15: Bar plot(s) showing the taxonomic abundance across the samples at phylum taxa level. (A) Bacteria; (B) Archaea and (C) Eukarya

4.2.5 Comparative metagenomics analysis of microorganisms in lagoon 1 and lagoon 2

a. Microbial composition at the domain, phylum, class, and family levels

The sludge in lagoon 2 had just completed the anaerobic digestion period and was ready to be released into the drying beds. Figure 10 in section 4.2.2 illustrates the general metagenomic classification found in the two lagoons. Bacteria dominated the microbial

community of sewage sludge with abundances ranging from 91.13% to 93.41%. Archaea 6.03% to 8.21%, eukaryotes 0.38% to 0.41% and viruses followed it with sub-dominance ranging from 0.08% to 0.17% (table 10). The paired t-test indicated that there was significant (P-value<0.05) difference in the domain distribution between lagoon 1 and lagoon 2. The bacteria abundance was slightly higher in lagoon 1 ($92.87 \pm 0.27\%$) compared to lagoon 2 (91.13%).

The eukaryotes also recorded a significantly higher dominance ($0.41 \pm 0.01\%$) in lagoon 1 than the abundance (0.39 ± 0.01) in lagoon 2 but much lower than bacteria or archaea. In archaea, the abundance ($7.96 \pm 0.26\%$) in lagoon 2 was higher compared to the dominance ($6.59 \pm 0.28\%$) of lagoon 1. The viruses also recorded a relatively higher (2 times) dominance in lagoon 2 of $0.16 \pm 0.01\%$ compared to 0.08% in lagoon 1 (Table 10). The low dominance of eukaryotes and viruses suggests their inability to cope with the environmental conditions in the sludge digesters.

At phylum level, 56 phyla were found in this study and 13 were identified as major phyla. Among the 13, 11 were bacteria, 1 archaea and 1 eukaryotic (Fig 16). The metagenomics data sets in this study found that *Proteobacteria* was the most dominant phylum ranging between 23.87-27.94% and averaging at $26.41 \pm 1.57\%$ in the two lagoons. The sub-dominant phyla were the *Bacteroidete* (averaging at $19.61 \pm 4.00\%$), *Firmicutes* (averaging at $18.60 \pm 1.14\%$) and the *Actinobacteria* (averaging at $16.83 \pm 7.37\%$). Most of the archaea belonged to the phyla *Euryarchaeota* (averaging at $8.77 \pm 1.13\%$). The *Cyanobacteria* averaged at $0.38 \pm 0.03\%$. Fig. 13 section 4.2.2 gives a snapshot of the different hierarchies of metagenomics classification in this study.

The dominant classes were *Actinobacteria* ($26.17 \pm 5.45\%$ in lagoon 1; $12.31 \pm 0.49\%$ in lagoon 2), *Bacteroidia* ($11.45 \pm 2.35\%$ in lagoon1; $14.84 \pm 0.35\%$ in lagoon 2) and *Clostridia* ($14.1 \pm 0.22\%$ in lagoon 1; 13.36 ± 0.23 in lagoon 2) (Fig 17). These classes showed significant differences in their abundance between lagoon 1 and 2 with p-value of 0.989, 0.999 and 0.208 for *Actinobacteria*, *Bacteroidia* and *Clostridia* respectively.

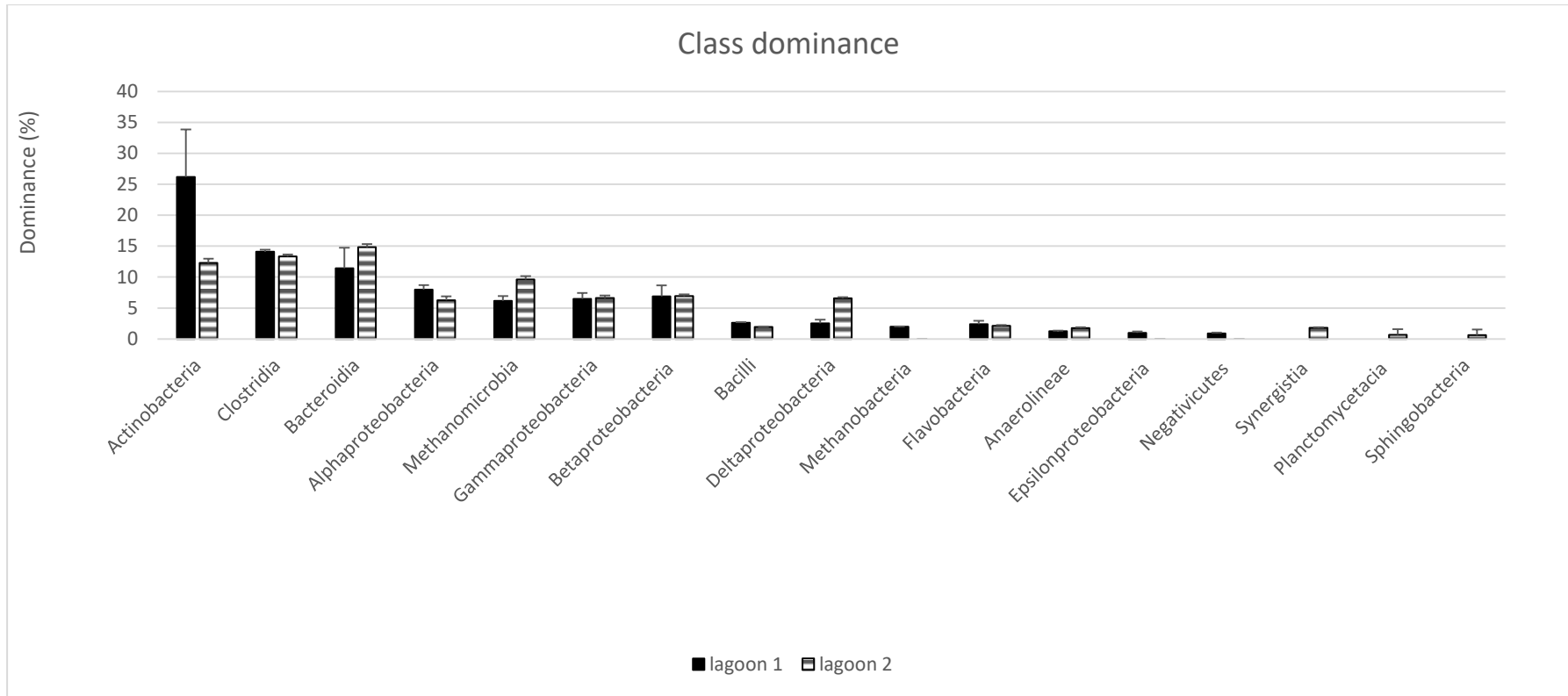

Figure 17: Bar graph showing the class dominance in the two lagoons

The subdominant groups were *Alphaproteobacteria* ($7.99 \pm 0.49\%$ in lagoon 1; $6.27 \pm 0.44\%$ in lagoon 2), *Methanomicrobia* ($6.16 \pm 0.55\%$ in lagoon 1; $9.63 \pm 0.38\%$ in lagoon 2), *Gammaproteobacteria* ($6.5 \pm 0.67\%$ in lagoon 1; $6.63 \pm 0.29\%$ in lagoon 2), *Betaproteobacteria* ($6.88 \pm 1.26\%$ in lagoon 1; $6.93 \pm 0.20\%$ in lagoon 2), *Bacilli* ($2.62 \pm 0.06\%$ in lagoon 1; $1.95 \pm 0.05\%$ in lagoon 2), and *Deltaproteobacteria* ($2.54 \pm 0.42\%$ in lagoon 1; $6.59 \pm 0.11\%$ in lagoon 2). The two-sample t-test recorded significant differences in all the subdominant classes. Class *methanobacteria* ($2.00 \pm 0.03\%$), *Epsilonproteobacteria* ($1.79 \pm 0.06\%$) and *Negativicutes* ($0.66 \pm 0.06\%$) were unique to lagoon 1. *Synergistia* ($1.85 \pm 0.85\%$), *Planctomycetacia* ($2.00 \pm 0.03\%$), and *Sphingobacteria* ($0.64 \pm 0.64\%$), were unique classes to lagoon 2.

At the family levels, the *Methanosarcinaceae* ($6.05 \pm 1.40\%$ in lagoon 1; $2.68 \pm 0.06\%$ in lagoon 2), *Mycobacteriaceae* ($5.50 \pm 1.52\%$ in lagoon 1; $2.52 \pm 0.09\%$ in lagoon 2), *Clostridiaceae* ($4.87 \pm 0.53\%$ in lagoon 1; $4.65 \pm 0.12\%$ in lagoon 2), and *Bacteroidaceae* ($5.17 \pm 1.40\%$ in lagoon 1; $5.99 \pm 0.33\%$ in lagoon 2) were the dominant families in the sludge (Fig 18). T-test recorded no significant difference between lagoon 1 and 2 with a p-value of 0.9999, 0.9915, 0.3375, and 0.2183 for *Methanosarcinaceae*, *Mycobacteriaceae*, *Clostridiaceae* and *Bacteroidaceae* abundances.

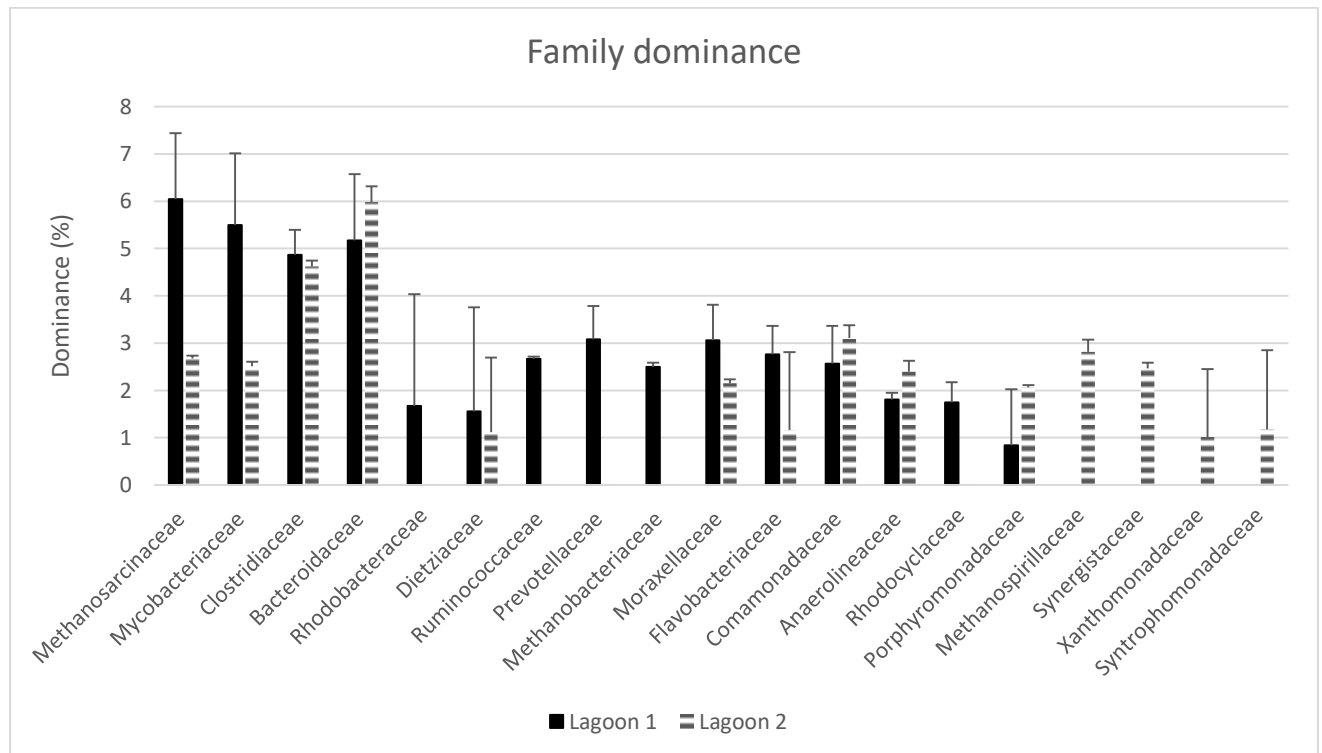

Figure 18: Bar graph showing the family dominance in the two lagoons

The genes placements of the sequences hits indicated that the families *Dietziaceae* ($1.55 \pm 0.19\%$ in lagoon 1; $1.15 \pm 0.58\%$ in lagoon 2), *Moraxellaceae* ($3.06 \pm 0.75\%$ in lagoon 1; $2.16 \pm 0.08\%$ in lagoon 2), *Flavobacteriaceae* ($2.77 \pm 0.60\%$ in lagoon 1; $1.17 \pm 0.08\%$ in lagoon 2), *Comamonadaceae* ($2.77 \pm 0.60\%$ in lagoon 1; $1.17 \pm 0.08\%$ in lagoon 2), *Anaerolineaceae* ($1.81 \pm 0.15\%$ in lagoon 1; $2.34 \pm 0.23\%$ in lagoon 2) and *Porphyromonadaceae* ($1.18 \pm 0.84\%$ in lagoon 1; $2.07 \pm 0.05\%$ in lagoon 2). All the families were significantly different between lagoon 1 compared to lagoon 2. The families *Rhodobacteraceae* ($1.67 \pm 0.36\%$), *Ruminococcaceae* ($2.64 \pm 0.04\%$), *Prevotellaceae* ($3.08 \pm 0.71\%$), *Methanobacteriaceae* ($1250 \pm 0.08\%$) and *Rhodocyclaceae* (1.75 ± 0.43) were the subdominant groups unique to lagoon 1. *Methanospirillaceae* (2.82 ± 0.25), *Synergistaceae* (2.47 ± 0.12), *Xanthomonadaceae* (1.02 ± 0.44), and *Syntrophomonadaceae* (1.18 ± 0.67) were the subdominant group unique to lagoon 2.

4.2.3.2 Relative abundances and alpha diversity of the genera in all the samples

The results on genera abundances are shown in Fig 19. Generally, lagoon 1 was dominated by the Euryarchaeota archaea genus *Methanosarcina* ($6.55 \pm 1.45\%$), the gram positive *Mycobacterium* ($6.31 \pm 1.68\%$), the fecal indicator gram negative *Bacteroides* ($5.95 \pm 1.67\%$), and the gram positive *Clostridium* ($5.95 \pm 1.67\%$). In lagoon 2, *Bacteroides* ($6.78 \pm 0.38\%$), *Clostridium* ($4.81 \pm 0.12\%$), and a syntrophic bacteria, *Candidatus Cloacamonas* ($4.29 \pm 0.36\%$). T-test showed that *Methanosarcina* ($P=0.9998$), *Mycobacterium* ($P=0.9986$), *Bacteroides* ($P=0.2465$) and the *clostridium* ($P=0.9997$) were not significantly different in the two lagoons. The species *Candidatus cloacamonas* was unique to lagoon 2

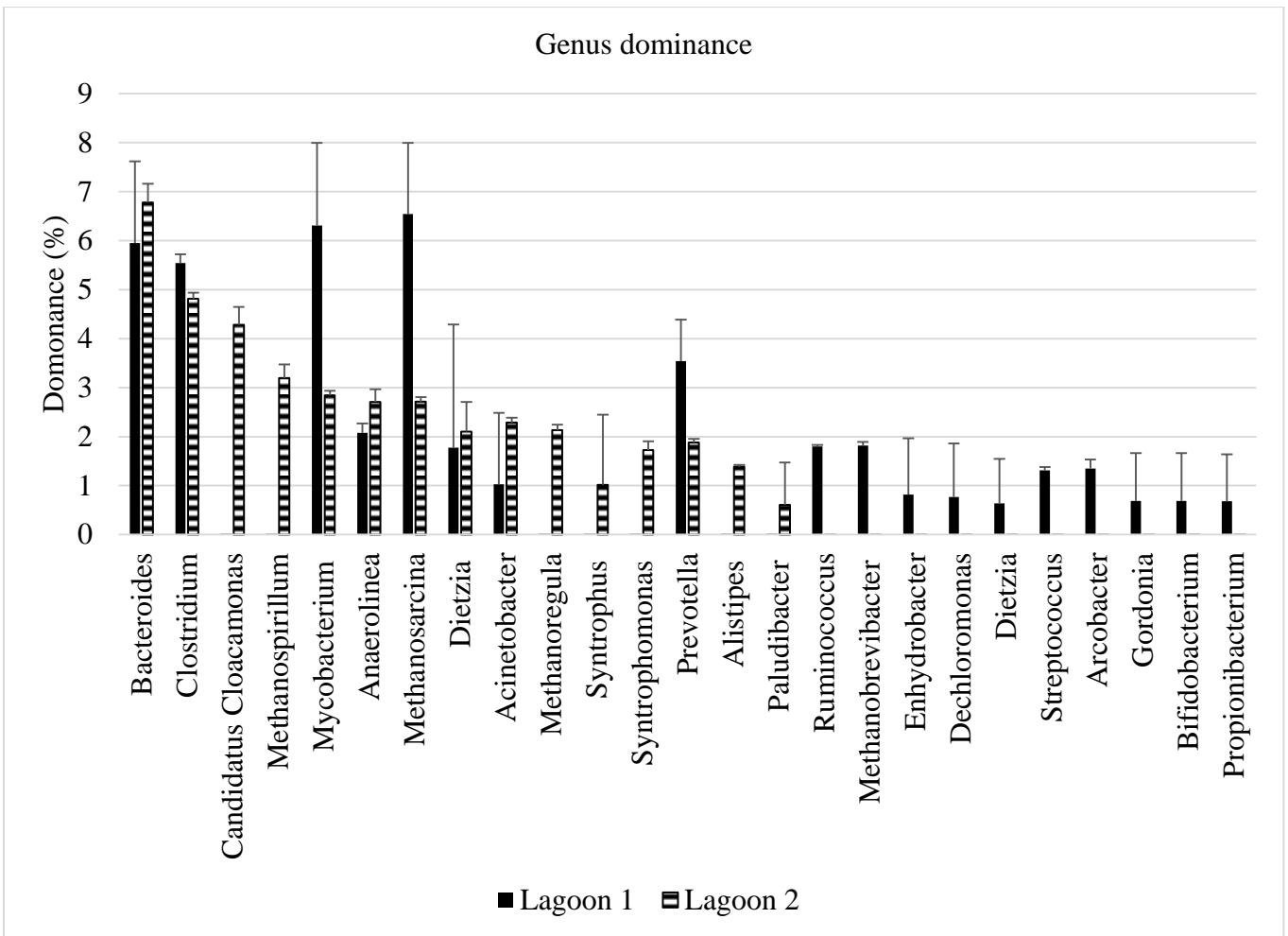

Figure 19: Bar graph showing the genera dominance in the two lagoons

In composite sample 1b (Fig.20), the highest average abundance was between *Metanosarcina* and *Mycobacterium* but decreased with a relatively steep gradient from *Clostridium* to *Ruminococcus* in the head region. The middle region and the tail region showed a shallow decrease in the abundances between the genera *Actinobacter* and *Geobacter*. The change of abundance gradient from relatively steep to shallow gradient indicates that the evenness of the distribution increases as the abundance decreases from *Metanosarcina* to *Geobacter*

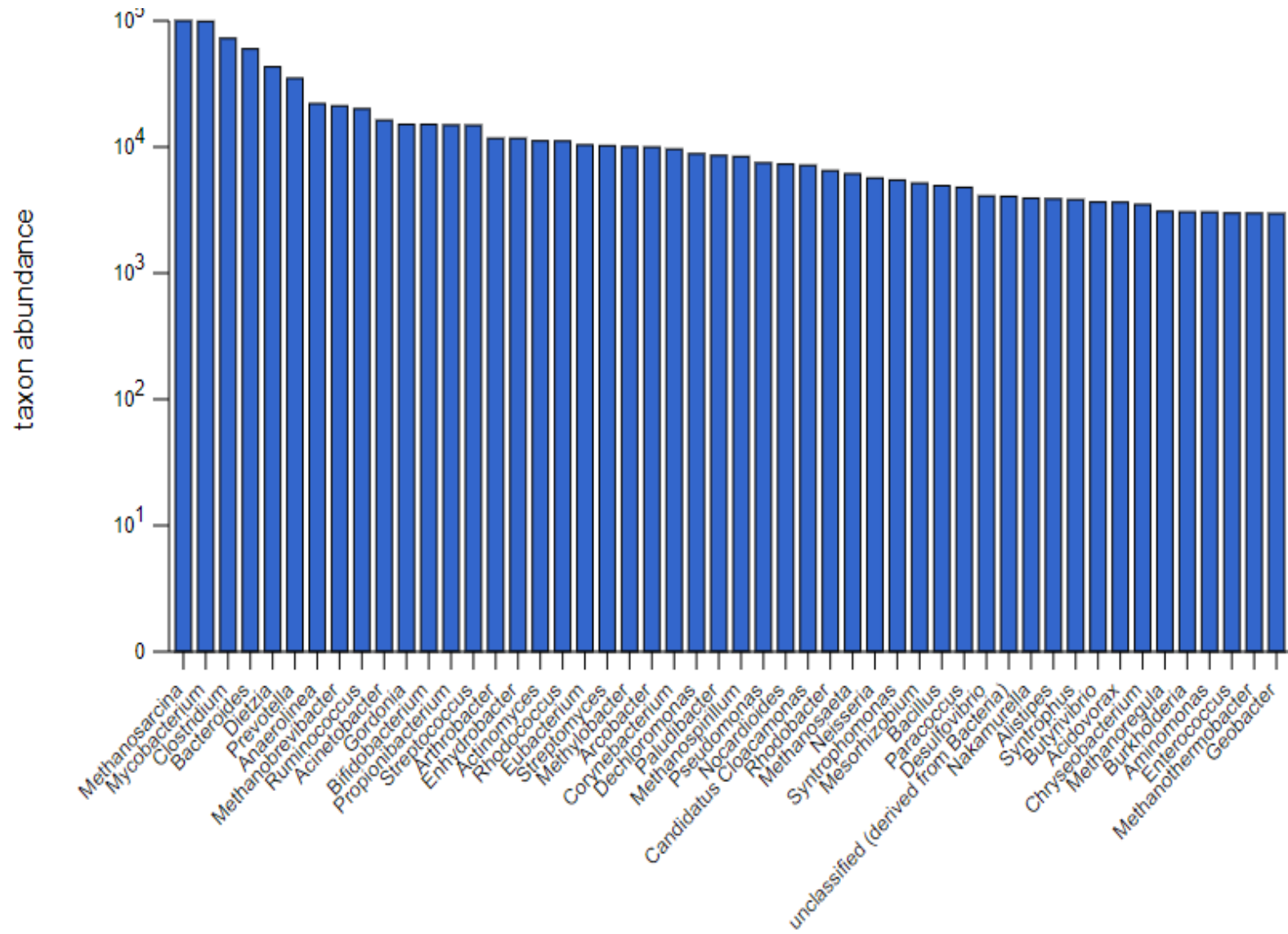

Figure 20: Composite sample 1b rank abundance plot by genus

Bacteroides and *Mycobacterium* had the highest average abundance in sample 1c (Fig.21). The abundance steeply decreases between *Clostridium* and *Anaerolinea* in the head region indicating low genus evenness. Increased genus evenness is noted as the gradient becomes shallow gradient between genus *Methanobrevibacter* and *Geobacter*. The average abundance of the genera ranged between 10^6 and $10^{3.5}$ hits.

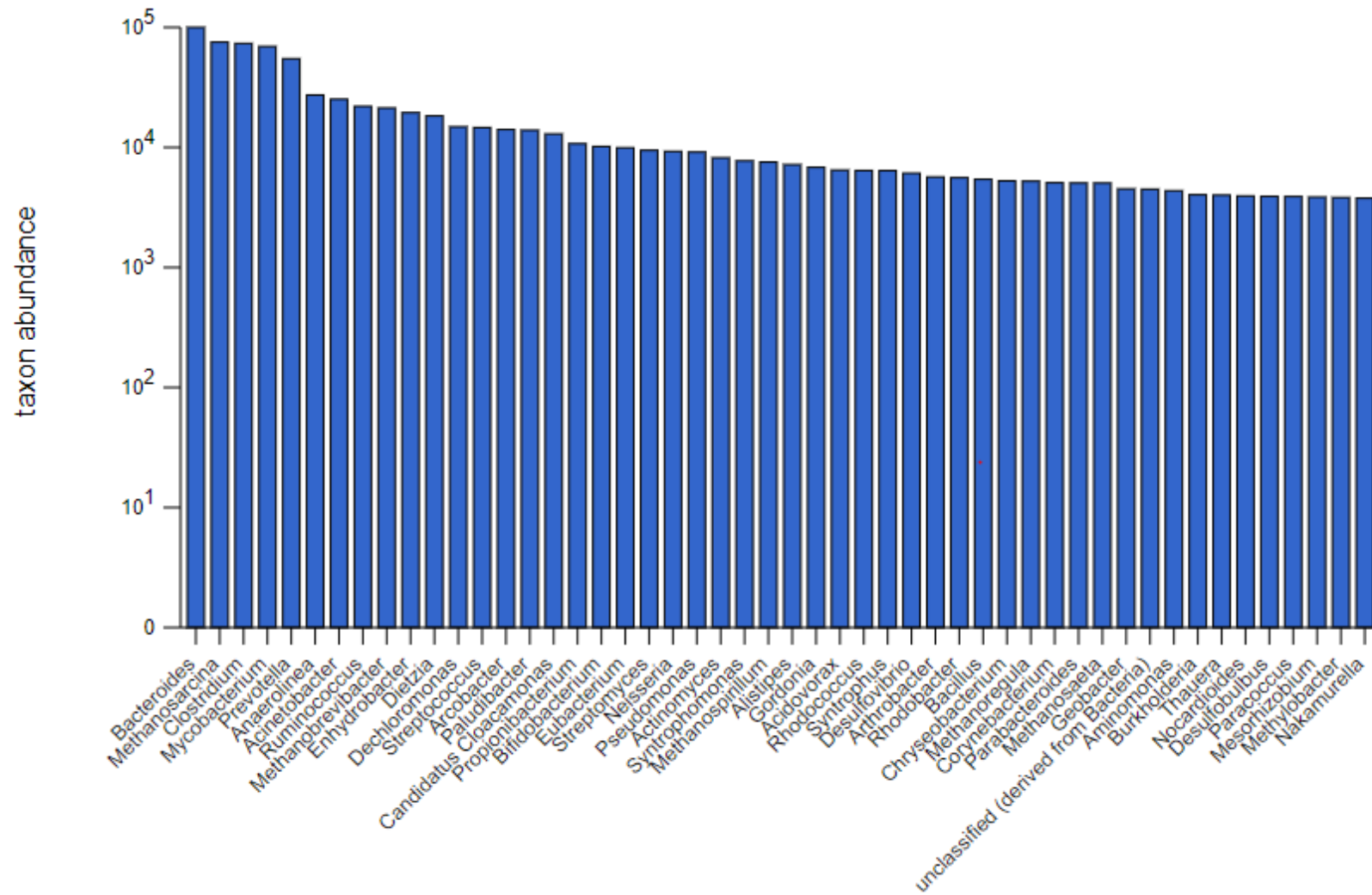

Figure 21: Composite sample 1c rank abundance plot by genus

In sample 2a, highest abundance was dominated by the *Bacteroides* (10^4 hits) and decreasing with a shallow gradient to *Paeniacillus* (Fig.22). Generally, there was a shift of genera richness compared to samples 1b and 1c. The same pattern is recorded in sample 2c (fig.23) with *Bacteroides* occupying the top of the abundance list as the gradient decreases with a shallow gradient to genus *Desulfatibacillum*. The highest abundance of the *Bacteroides* was recorded in sample 2c (10^5) than in 2a (10^4).

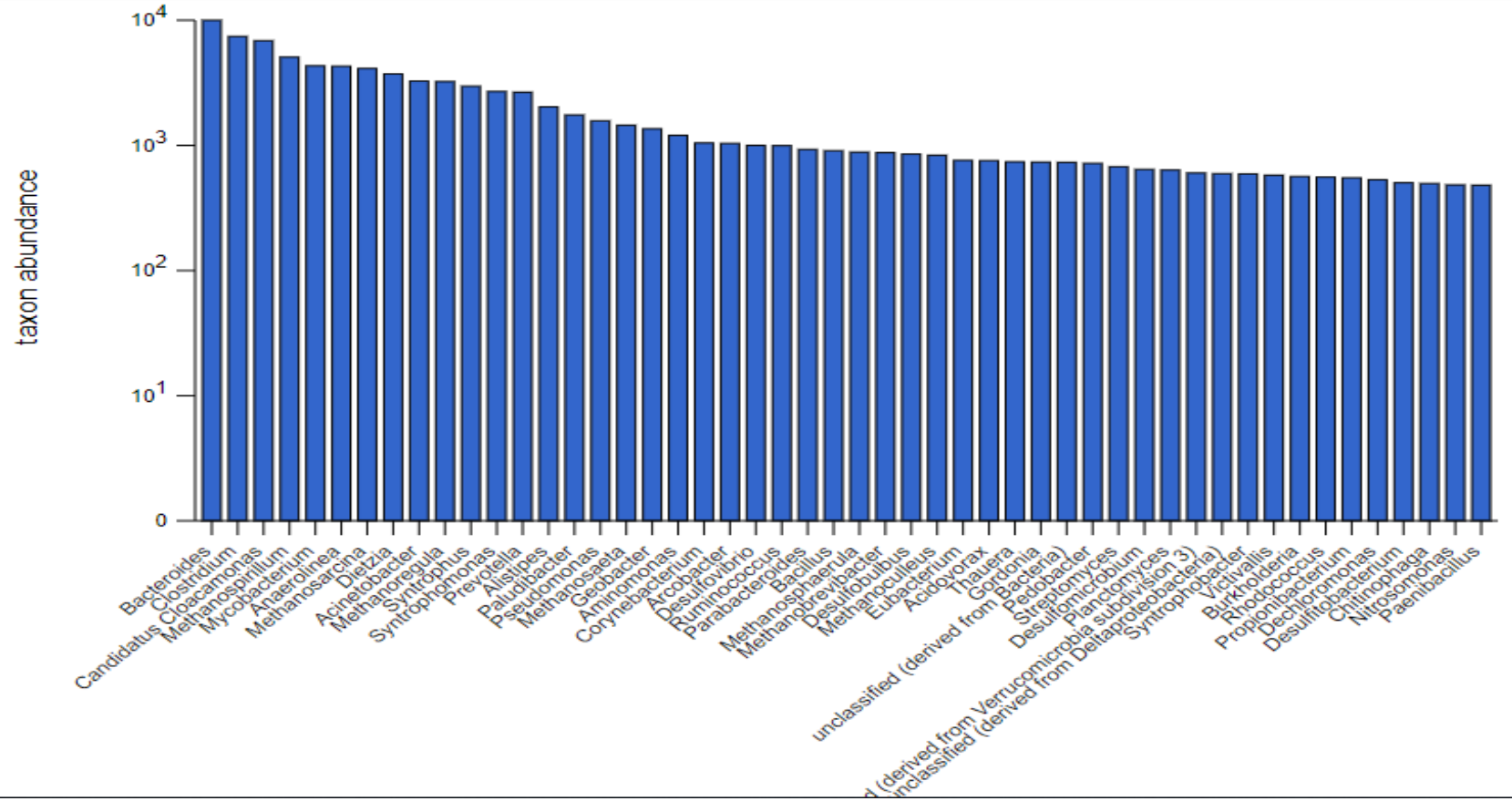

Figure 22: Composite sample 2a rank abundance plot by genus

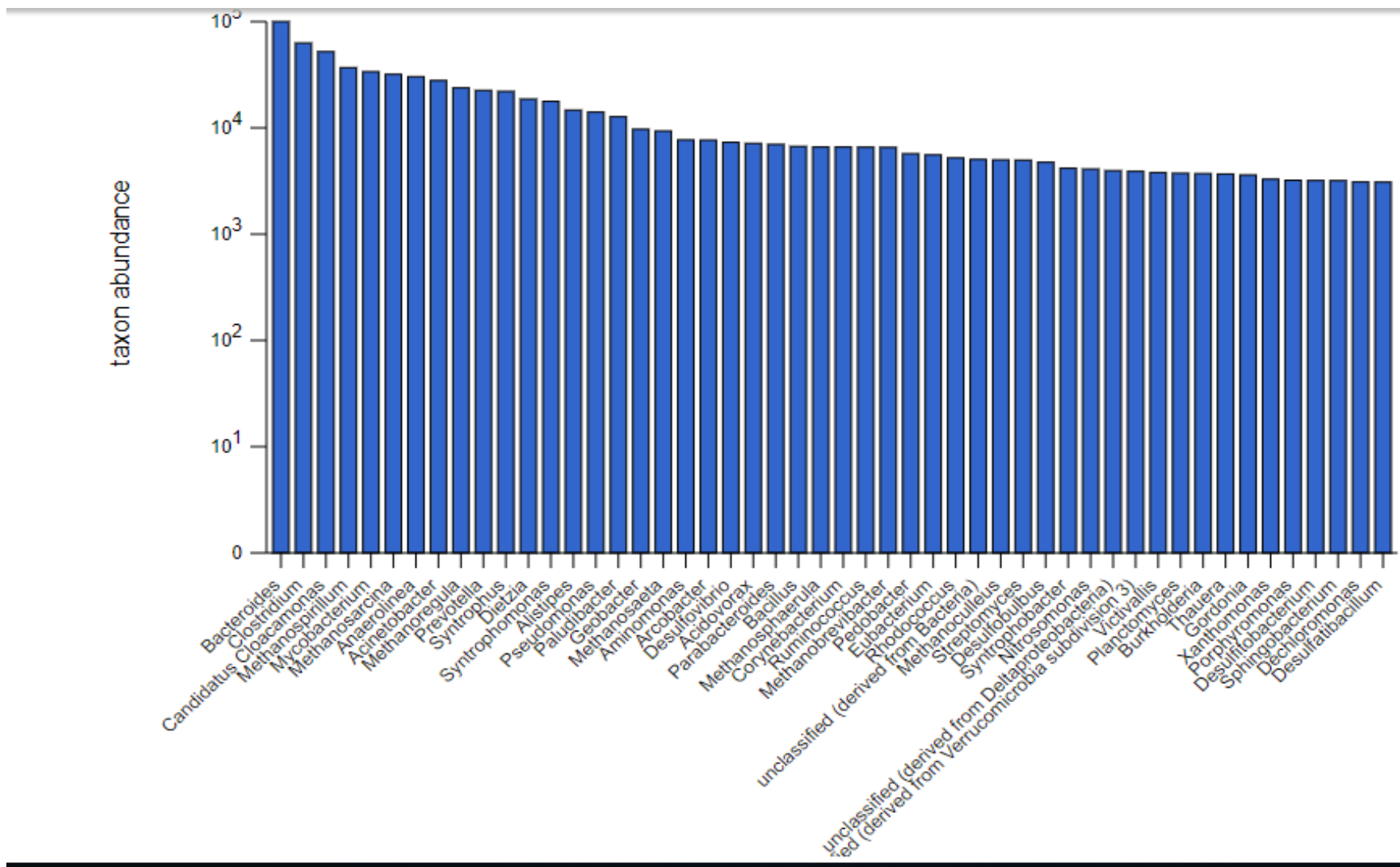

Figure 23: Composite sample 2c rank abundance plot by genus

The alpha diversity was estimated for each sample by MG-RAST. It was represented as a single number that summarizes the distribution of species-level annotations in a composite sample dataset (Fig 24).

Shannon species richness was assigned units of the “effective number of species”. The species-level annotations were from all the annotation source databases used by MG-RAST.

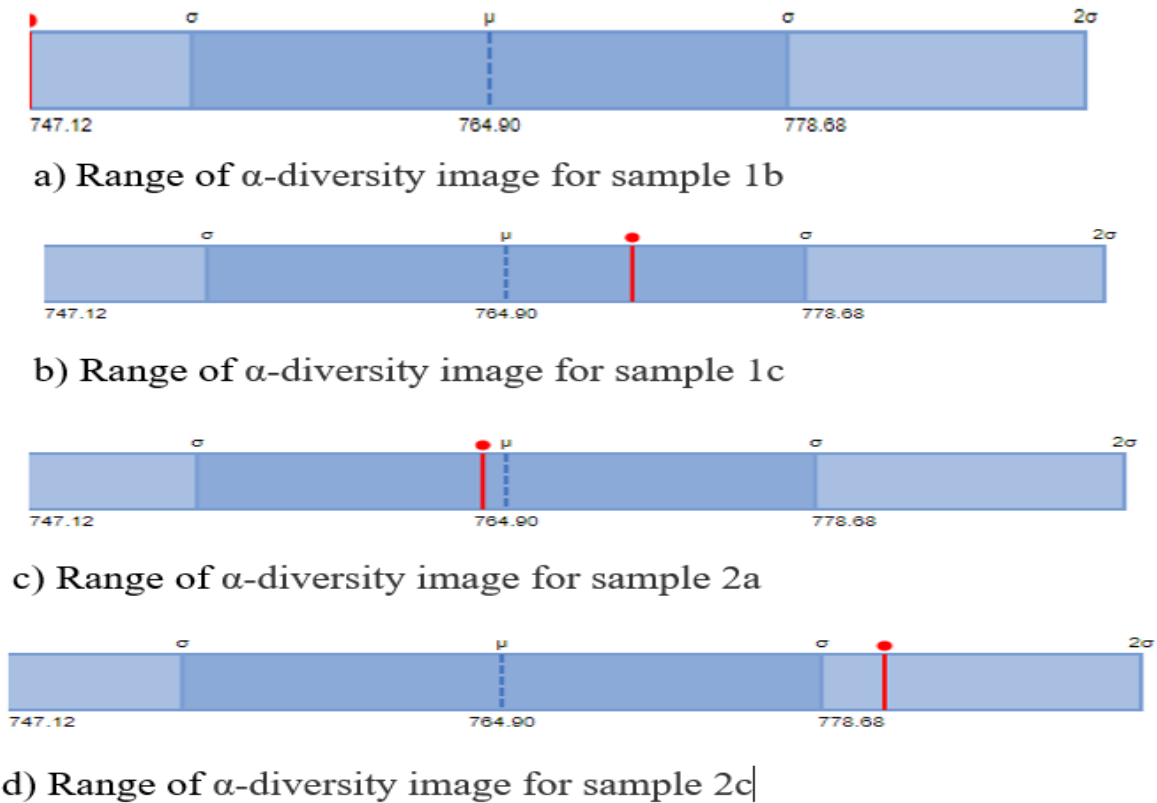
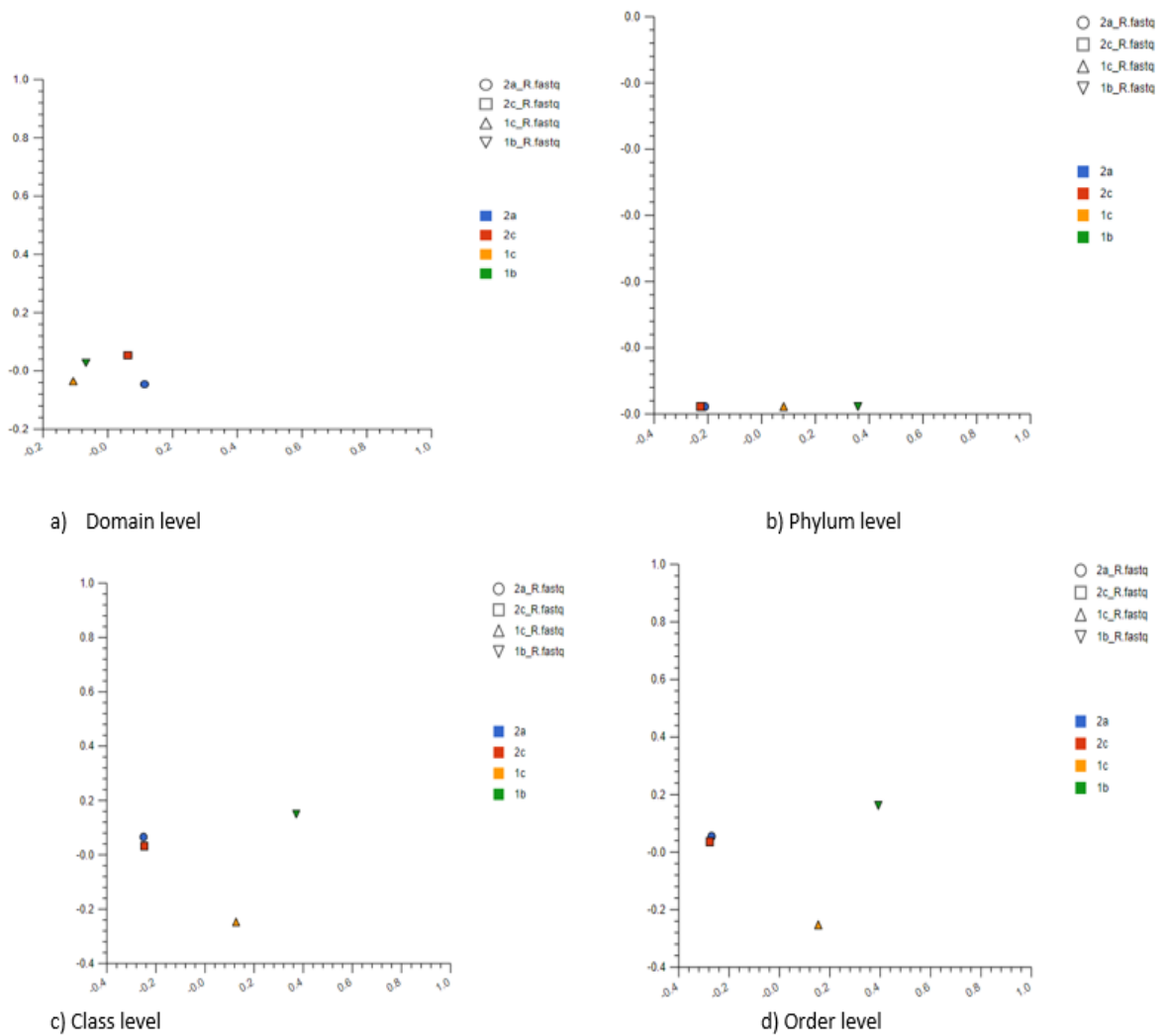

Figure 24: Alpha diversity plots showing the range of α -diversity values in the composite samples 1b, 1c, 2a and 2c data sets computed by MG RAST. The min, max, and mean values are shown, with the standard deviation ranges (σ and 2σ) in different shades. The α -diversity of each sample metagenome is shown in red.

The highest alpha diversity was recorded in composite sample 2c (779 species) followed by sample 1c with an α -diversity of 770 species. Sample 2a had an α -diversity of 764 species while the lowest α -diversity of 747 species was recorded in sample 1b. Generally, lagoon 2 was more diverse in species composition compared to lagoon 1.

4.2.3.3 The compositional similarity among sludge samples

The similarity patterns of the four (4) composite samples were evaluated in the MG-RAST through the principal coordinate analysis (PCoA) based on Bray-curtis distance analysis and results presented in Fig. 25.



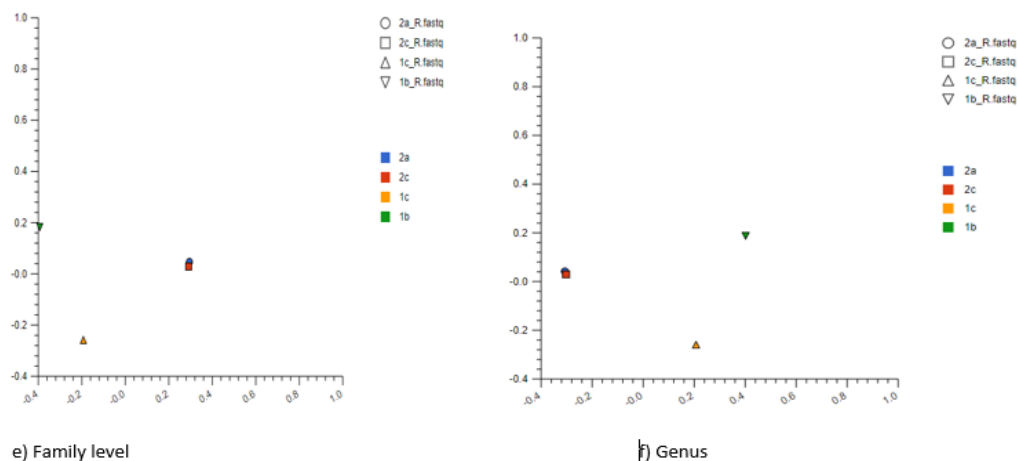
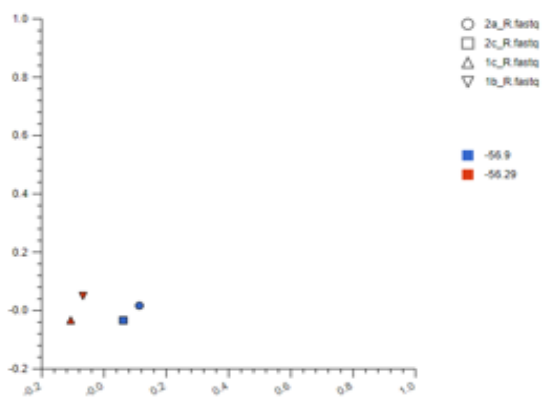

Figure 25: Principal coordinate analysis (PCoA) of four composite samples at for various taxa (a) Domain, (b) Phylum, (c) Class, (d) Order, (e) family and (f) genus levels. PCoA (A and B) was conducted using the Bray–Curtis distance and a transformation exponent of two (2). With x-axis representing PCoA 1 while y-axis representing PCoA 2.

It was hypothesized that the aging differences of the sludge lagoons would result in significant difference in the microbial structure between samples of the two lagoons. As shown in fig. 25 a-f. The PCoA based on abundance of; (a) domain, (b) phyla, (c) class, (d) order, (e) family and (f) genus levels, revealed that the four composite samples could be clustered into three sub groups for all the levels except in the domain level where the clustering was in two subgroups. As demonstrated in the phyla, class, order, family and genus levels; sub-group I is composed of sample 2a and 2c; Sub-group II : Sample 1b and sub-group III: 1c. At the domain level; Sub-group I: Sample 2a and 2c while subgroup II: Samples 1b and 1c (fAppendix 2). As demonstrated by PCoA, at the domain level, samples 2a and 2c of lagoon 2; and samples 1b and 1c of lagoon 2 were certainly similar to each other possibly due to the same aging factor. PCoA revealed that the Phyla, class, order, family and genus levels were similar in samples 2a and 2c of lagoon 2 but samples 1b and 1c from lagoon 1 were dissimilar to each other. The grouping pattern of the samples of the different levels displayed by the PCoA patterns were similar to the mixed variation patterns of Oxidation-reduction potential (ORP), Dissolved oxygen (DO), Electrical Conductivity (EC), pH, and Temperature (fig.26).

1. Oxidation reduction potential



a) Domain level

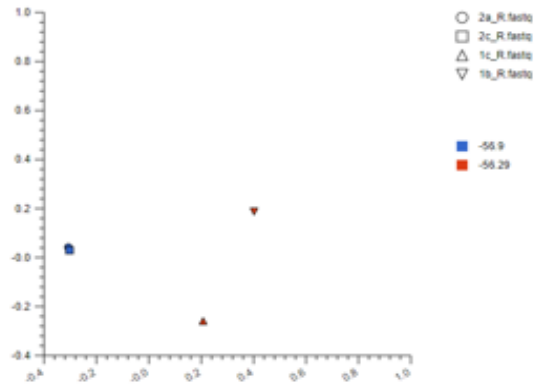

b). Genus level

2. Dissolved Oxygen

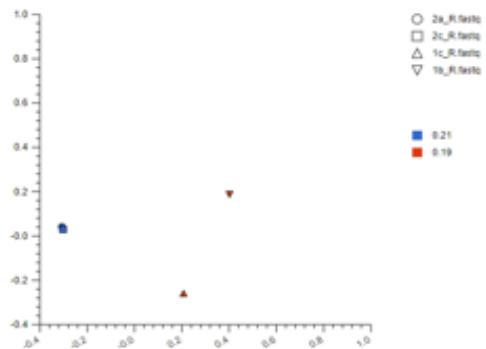
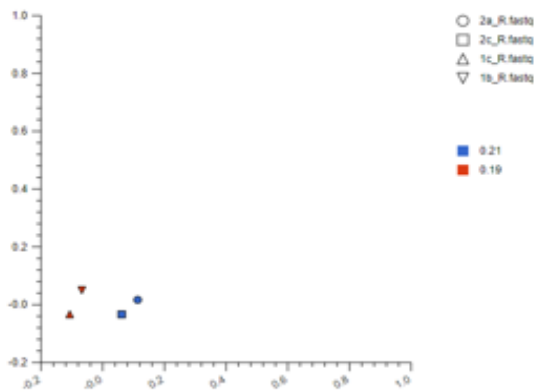

3. Electrical Conductivity

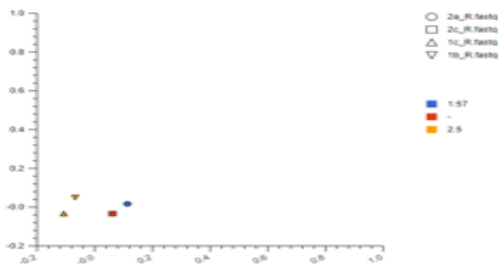

a) Domain level

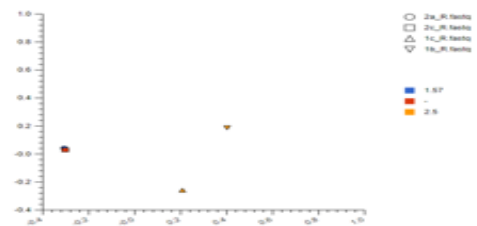

b) Genus level

4. pH

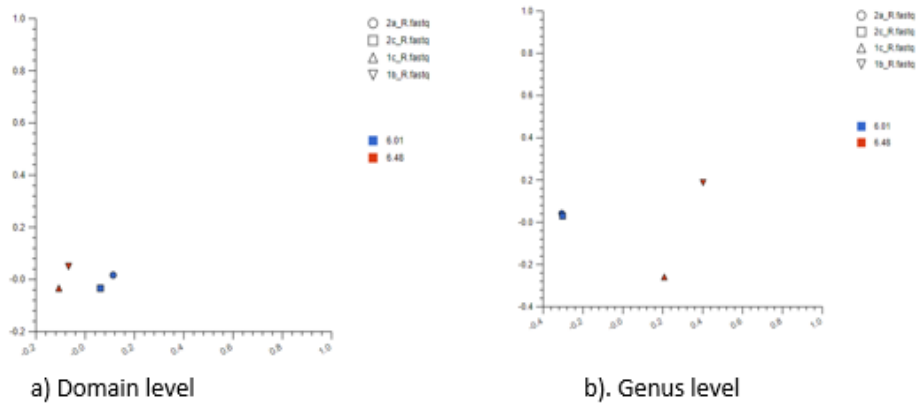

5. Temperature

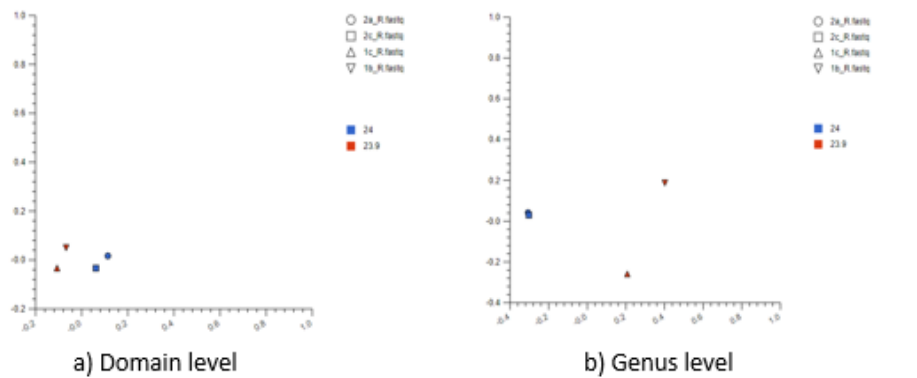

Figure 26: Principal coordinate analysis (PCoA) of four composite samples at a) Domain and b). Genus levels of 1. Oxidation-reduction potential (ORP), 2. Dissolved oxygen (DO), 3. Electrical Conductivity (EC), 4. pH, and 5. Temperature. PCoA as conducted using the Bray–Curtis distance). With x-axis representing PCoA 1 while y-axis representing PCoA 2.

4.3 Functional profiling of methanogenic microbial community

4.3.1 General functional profiles of the two lagoons

To explore the metabolic potential of the studied community, a detailed analysis of metagenomics sequences was performed against the KO and the SEED Subsystems within the MG-RAST pipeline. An average of 68363 functional hits were detected of all the annotated reads (Appendix 3). Genes annotated to metabolism were recorded the highest in the sludge samples (Fig.27). The functional categories were not significantly different ($F(3,48)=0.768$, $p=0.5176$) in the four samples even through samples 1b and 1c in lagoon one recorded a higher

functional abundance compared to samples 2a and 2c of lagoon 2 (table 11). This indicates that lagoon 1 was functionally active compared to lagoon two (Fig. 27).

Table 10: ANOVA test for the functional groups

Test for equal means	Sum of sqrs	Df	Mean square	F	p
Between groups:	410551	3	136850	0.768	0.5176
Within groups:	8.55E+06	48	178185		
Total:	8.96E+06	51	0.5524		

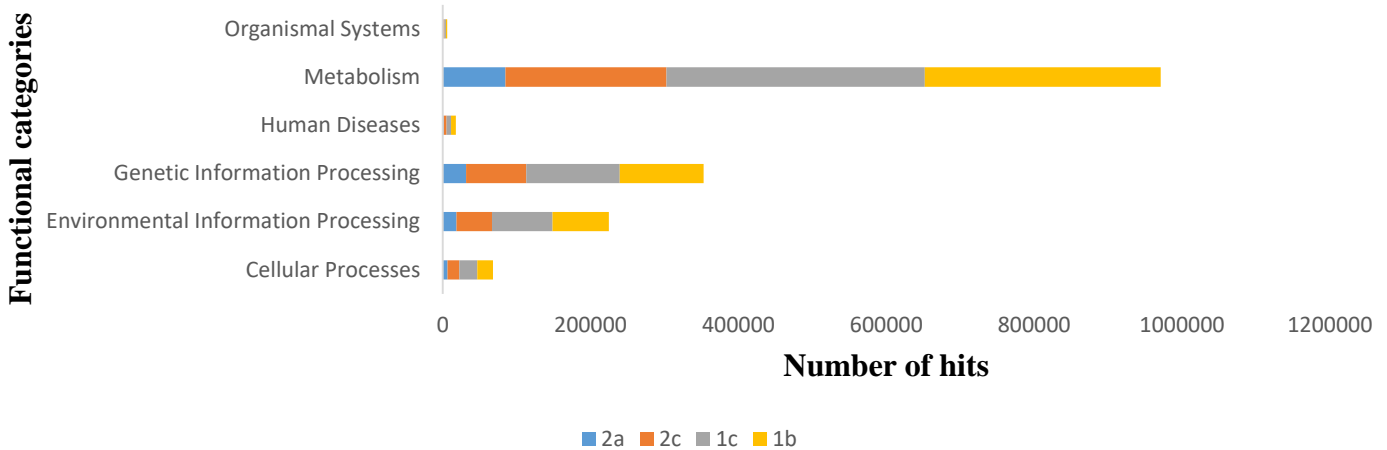

Figure 27: composition of the functional categories across the samples

Analysis of the commonly used diversity, evenness, and richness indices showed that all the samples were quite similar as far as the indices are concerned (see table 12). The most functionally diverse and even was sample 2a community (Shannon–Wiener index—1.117, Pielou index 0.5091) while the least one was sample 1b metagenome (Shannon–Wiener index—1.112, Pielou index 0.507) (Table 12). Even though samples in lagoon 1 had higher abundance of species with functional genes, lagoon 2 recorded a higher functionally diverse and evenly distributed species. Furthermore, similarly to RefSeq Bray–Curtis distances calculation, some samples similar to each other e.g., 1c and 1b (95%), 1b and 2c (81%) and sample 1c and 2c (77%). while samples 2a and 1c (39%) were the most different from majority of the analyzed metagenomes followed by samples 2a and 1b (42%). Even though samples 2a and 2c were collected from the same lagoon 2, they were relatively dissimilar to each other at 56% (Table 13).

Table 11: Common alpha diversity indices of the samples

	Sample 2a	Sample 2c	Sample 1c	Sample 1b
Individuals	143270	368760	591151	537534
Dominance_(D)	0.4172	0.4167	0.4169	0.4182
Simpson_1-D	0.5828	0.5833	0.5831	0.5818
Shannon_H	1.117	1.116	1.116	1.112
Evenness_e^H/S	0.5091	0.5087	0.5088	0.507
Equitability_J	0.6232	0.6227	0.6229	0.6209
Fisher_alpha	0.4756	0.4399	0.4241	0.4272

Table 12: Bray-Curtis's beta diversity of (dis)similarity

	2a	2c	1c	1b
2a	100%	56%	39%	42%
2c	56%	100%	77%	81%
1c	39%	77%	100%	95%
1b	42%	81%	95%	100%

4.3.2 Functional profiles of relevant metagenomics pathways[√]

The study focused on functional analysis relevant to the metagenomics pathways. The relative abundance of methanogenesis-related genes was presented from the functional annotations of SEED subsystems analyzed by MG-RAST server. Annotation were run against methanogenesis related enzymes namely; formylmethanofuran dehydrogenase (*fmd*); formylmethanofuran-H4MPT formyltransferase (*ftr*); methenyl-H4MPT cyclohydrolase (*mch*); methylene-5,6,7,8-H4MPT dehydrogenase (*mtd*); H₂-forming N₅,N₁₀-methylene-H4MPT dehydrogenase(*hmd*); 5,10-methylene-H4MPT reductase (*mer*); H4MPT-methyltransferase (*mtr*); acetate kinase (*ack*); phosphate acetyltransferase (*pta*); acetyl-CoA synthetase (*acs*); CO dehydrogenase/acetyl CoA synthase(*cdh*); methanol-specific methyltransferase complex (*mta*); methylamine-specific methyltransferase complex (*mtb*); the CoB-CoM heterodisulfide reductase (*hdr*); and the methyl CoM reductase (*mcr*) that participates in the final release of methane gas.

The hits relating to the methane production genes were not significantly different in the four composite samples with $p=0.2517$. Even though the highest number of hits were recorded in sample 1c (4037) and the least hits in 2a (1065), sample 2a community was the most functionally diverse and even with (Shannon–Wiener index—1.68, Pielou index 0.4167) while the least one was sample 1b metagenome (Shannon–Wiener index—1.112, Pielou index 0.507) (Table 14).

Table 13: Alpha diversity indices for the total methane functional categories

	Sample 2a	Sample 2c	Sample 1c	Sample 1b
Individuals	1065	2706	4037	3701
Dominance_D	0.2888	0.2932	0.306	0.295
Simpson_1-D	0.7112	0.7068	0.694	0.705
Shannon_H	1.69	1.662	1.605	1.653
Evenness_e^H/S	0.4167	0.4053	0.3831	0.4019
Equitability_J	0.6587	0.6479	0.6259	0.6446
Fisher_alpha	2.084	1.773	1.668	1.69

Bray–Curtis similarity calculation (Table 15) indicated a 93% similarity in the sequence profiles of the selected genes between samples 1b and 1c probably because they came from the same lagoon. Interestingly, sample 1b and 2b were 84% similar even though they belonged to different lagoons. Samples 1c and 2c were also considerably similar (80%). The lagoon two samples 2a and 2c were different from each other with similarity value of 56% (Table 15).

Table 14: Bray-Curtis similarity analysis of the samples

	Sample 2a	Sample 2c	Sample 1c	Sample 1b
2a2c	100%	56%	42%	45%
1c	56%	100%	80%	84%
1b	42%	80%	100%	93%
	45%	84%	93%	100%

Among the methane pathway selected genes, the *acs* genes were over-represented followed by the *ack* and the *pta* genes (see fig 28). Microbial consortia annotated to *cdh* genes were the most diverse and evenly distributed (Shannon–Wiener index—1.368, Pielou index 0.983). The least diverse consortia were annotated from *pta* genes (Shannon–Wiener index—1.149, Pielou index 0.7891). The microbial profiles consortia of the *mcr* gene responsible for the final release of methane recorded relatively moderate hits of 540 with a relatively diverse profiles (Shannon–Wiener index—1.317, Pielou index 0.9335) (Table 16).

Table 15: Alpha diversity of the methanogenesis related genes

	Acs	cdh	fmd	mtrB	ack	Hdr	mcr	Mer	mtb complex	mtd	mtdB	mtr	pta
Individuals	5518	138	391	35	2727	484	540	411	92	248	30	165	730
Dominance_D	0.2911	0.2591	0.2697	0.2756	0.2929	0.2719	0.2791	0.2992	0.3419	0.2668	0.308	0.2795	0.3577
Simpson_1-D	0.7089	0.7409	0.7303	0.7244	0.7071	0.7281	0.7209	0.7008	0.6581	0.7332	0.692	0.7205	0.6423
Shannon_H	1.291	1.368	1.341	1.322	1.286	1.335	1.317	1.272	1.192	1.347	1.231	1.317	1.149
Evenness_e^H/S	0.9095	0.982	0.9555	0.9381	0.9047	0.9497	0.9335	0.892	0.8232	0.9614	0.8559	0.9335	0.7891
Equitability_J	0.9315	0.9869	0.9671	0.9539	0.9277	0.9627	0.9503	0.9176	0.8597	0.9716	0.8878	0.9503	0.8291
Fisher_alpha	0.422	0.7701	0.6203	1.164	0.4605	0.5971	0.5859	0.6147	0.8528	0.6773	1.24	0.739	0.5572

Enzymes included; formylmethanofuran dehydrogenase (*fmd*); formylmethanofuran-H4MPT formyltransferase (*ftr*); methenyl-H4MPT cyclohydrolase (*mch*); methylene-5,6,7,8-H4MPT dehydrogenase (*mtd*); H2-forming N5,N10-methylene-H4MPT dehydrogenase(*hmd*); 5,10-methylene-H4MPT reductase (*mer*); H4MPT-methyltransferase (*mtr*); acetate kinase (*ack*); phosphate acetyltransferase (*pta*); acetyl-CoA synthetase (*acs*); CO dehydrogenase/acetyl CoA synthase(*cdh*); methanol-specific methyltransferase complex (*mta*); methylamine-specific methyltransferase complex (*mtb*); the CoB-CoM heterodisulfide reductase (*hdr*); and the methyl CoM reductase (*mcr*).

Among the samples, hits annotated to the *mcr* genes responsible in the final release of methane gas were significantly higher in composite sample 1c with 159 hits and 1b with 159 hits both in lagoon one. Sample 2c recorded 146 hits while the lowest abundance was recorded in sample 2a with only 56 hits (Fig. 28).

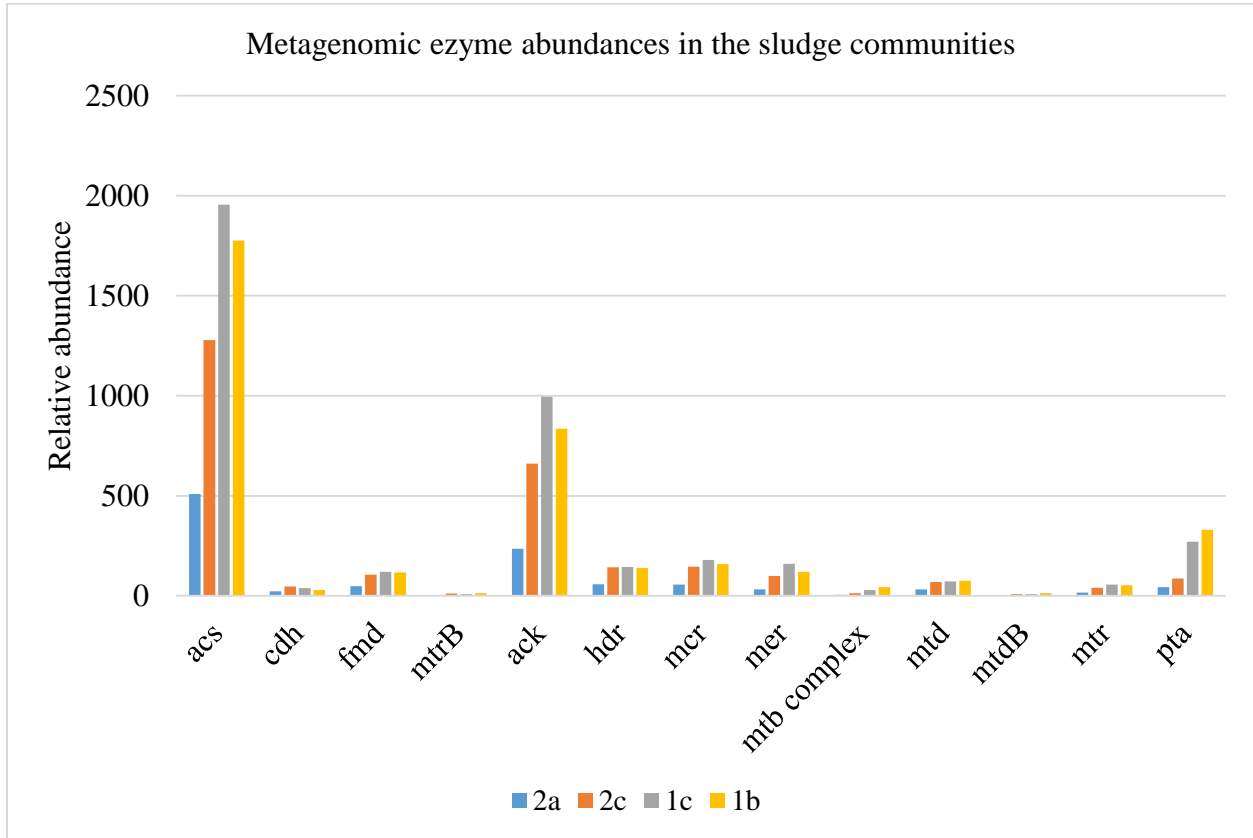

Figure 28: Relative abundance of hits annotated to the different methanogenesis related genes.

a. Organisms responsible for the last step of methanogenesis

This analysis revealed profiles annotated to the *mcr* (methyl CoM reductase) genes that participate in the final release of methane gas. These were found to be substantially different between the composite samples analyzed. The analysis of variance (ANOVA) to compare the means of the different samples revealed that there was significant difference in the abundance of the different samples ($F(3,112) = 2.779, p = 0.0436$) at $p < 0.05$ (Table 17).

Table 16: ANOVA analysis of the mcr profiles

Test for equal means					
	Sum of sqrs	df	Mean square	F	p
Between groups:	1867.03	3	622.345	2.779	0.04443
Within groups:	25078.1	112	223.912		
Total:	26945.2	115	0.0436		

The Dunn's post hoc test revealed no significance difference in all the samples except between sample 1c and 2a (Table 18).

Table 17: Dunn's Post Hoc test for mcr profiles

	Sample 2a	Sample 2c	Sample 1c	Sample 1b
2a		0.09728	0.02642	0.09338
2c	0.09728		0.5742	0.9843
1c	0.02642	0.5742		0.5877
1b	0.09338	0.9843	0.5877	

Among the mcr profiles, sample 1c recorded the highest hits while sample 2a recorded the lowest hits. Lagoon 1 samples recorded a relatively higher taxa score of 24 each while lagoon 2 samples recorded taxa score of 22 for sample 2 c and 21 for sample 2a. There was a generally low dominance among the lagoons ranging between D value of 0.07753 to 0.08682. Sample 2a was the most diverse and even (Shannon–Wiener index—2.743, Pielou index 0.7304) while sample 1b (Shannon–Wiener index—2.674, Pielou index 0.6042) was the least diverse and least even (Table 19)

Table 18: Diversity of species annotated to for the *mcr* genes

	Sample 2a	Sample 2c	Sample 1c	Sample 1b
Taxa_S	21	22	24	24
Individuals	148	364	460	388
Dominance_D	0.07979	0.07862	0.07753	0.08682
Simpson_1-D	0.9202	0.9214	0.9225	0.9132
Shannon_H	2.743	2.739	2.73	2.674
Evenness_e^H/S	0.7304	0.7029	0.6474	0.6042
Equitability_J	0.8968	0.886	0.8632	0.8415
Fisher_alpha	6.684	5.149	5.381	5.657

The composite sample 1b was dominated by the *Methanosarcina* (23%) which is known to produce methane using all the three metabolic pathways for methanogenesis (Gunsalus *et al.*, 2016). The thermophilic hydrogenotrophic *Methanothermobacter* (19%) and *Methanobrevibacter* (18%) were the subdominant groups in this sample (Fig.29). The *Methanosarcina barkeri* (15%) was most of the annotated species followed by *Methanothermobacter thermotrophicus* (14%) and *Methanobrevibacter smithii* (13%).

Genus composition of composite sample 1b

- Methanobrevibacter
- Methanococcoides
- Methanocorpusculum
- Methanohalophilus
- Methanopyrus
- Methanosaeta
- Methanosphaera
- Methanospirillum
- Methanocaldococcus
- Methanococcus
- Methanoculleus
- Methanoplanus
- Methanoregula
- Methanosarcina
- Methanosphaerula
- Methanothermobacter

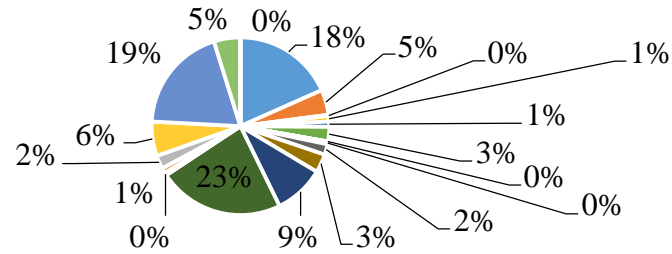

Figure 29: Genus level profiles of mcr genes annotated profiles in sample 1b

In sample 1c, *Methanothermobacter* (19%) was dominant while *Methanobrevibacter* (17%) and *Methanosarcina* (18%) were subdominant (Fig. 30). *Methanosarcina barkeri* (13%) and *Methanothermobacter thermoautotrophicus* (13%) formed the abundant species in this composite sample.

Genus composition of composite sample 1c

- Methanobrevibacter
- Methanococcoides
- Methanocorpusculum
- Methanohalophilus
- Methanopyrus
- Methanosaeta
- Methanosphaera
- Methanospirillum
- Methanothermus
- Methanocaldococcus
- Methanococcus
- Methanoculleus
- Methanoplanus
- Methanoregula
- Methanosarcina
- Methanosphaerula
- Methanothermobacter
- uncultured methanogenic archaeon RC-I

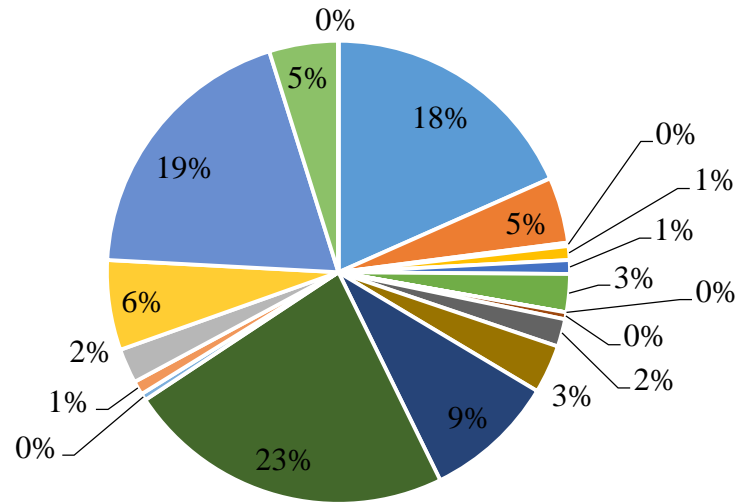

Figure 30: Genus level profiles of mcr genes annotated profiles in sample 1c

In sample 2c consortium, the dominant groups were the *Methanothermobacter* (13%), *Methanosaeta* (13%), *Methanoregula* (13%), and the *Methanosarcina* (12%) (Fig.31). At the species level, *mcr* gene hits annotated to *Methanosaeta thermophila* (14%) and *Methanoregula boonei* (13%) were found to be the most abundant in composite sample.

Genus composition of composite sample 2c

- Methanobrevibacter
- Methanococcoides
- Methanocorpusculum
- Methanohalophilus
- Methanopyrus
- Methanosaeta
- Methanosphaera
- Methanospirillum
- Methanothermobacter
- uncultured methanogenic archaeon RC-I
- Methanocaldococcus
- Methanococcus
- Methanoculleus
- Methanoplanus
- Methanoregula
- Methanosarcina
- Methanosphaerula
- Methanothermobacter
- Methanothermus

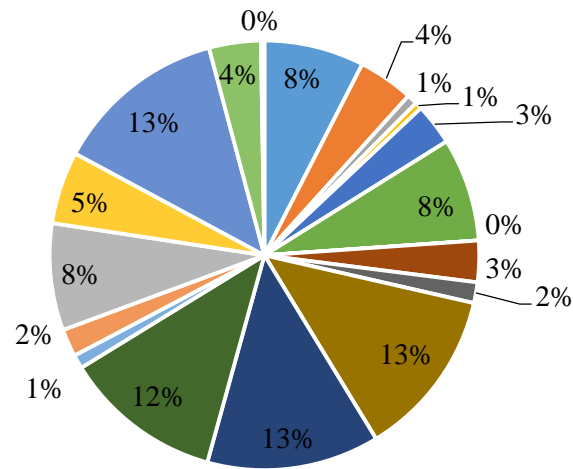

Figure 31: Genus level profiles of mcr genes annotated profiles in sample 2c

In sample 2a consortium, *Methanosaeta* (15%), *Methanothermobacter* (14%) and the *Methanosarcina* (13%) were the dominant genera (Fig. 32). The *Methanosaeta thermophila* (16%) and *Methanoregula boonei* (14%) were the abundant species in sample 2a. Fig. 32 indicates a cytoscape phylogenetic relationship between the mcr-annotated methanogens. Fig. 33 gives the abundance of the mcr-annotated methanogens in the different samples.

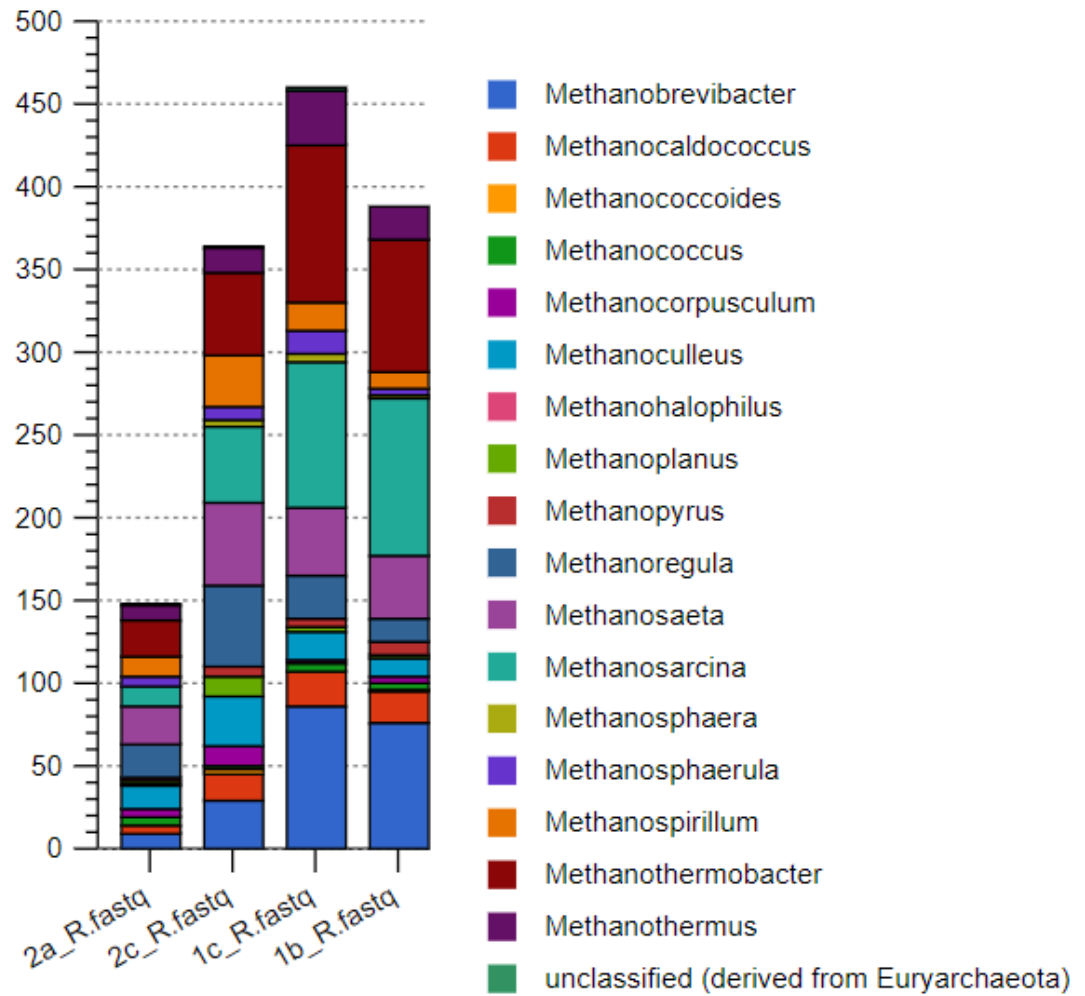

Figure 33: The abundance of the mcr-annotated methanogens in the different samples

The uncultured methanogenic archaeon RC-I was also recorded in all the samples except in sample 1b in low abundances indicating possible presence of lineages of uncultured archaea especially in lagoon 2.

Phylogenetic tree for archaea responsible for the final release of methane gas as annotated by mcr genes

In lagoon 1(samples 1c and 1b) the most parsimonious tree with length was 19285 as shown in link.

(<https://www.dropbox.com/s/kpnqvelf4mg3uvy/Lagoon%201%20mcr%20annotated%20genes%20phylogenetic%20tree.pdf?dl=0>). The consistency index was 0.042053 (0.041954), the retention index was 0.616841 (0.616841), and the composite index was 0.025940 (0.025879) for all sites and parsimony-informative sites. This analysis involved 467 nucleotide sequences. Codon positions included were 1st+2nd+3rd+Noncoding. There were a total of 282 positions in the final dataset.

Lagoon 2 (samples 2c and 2b) had parsimonious tree with length of 22947 as shown (<https://www.dropbox.com/s/zxkoehpkjf74xbf/Lagoon%20%20mcr%20annotated%20genes%20phylogenetic%20tree.pdf?dl=0>). The consistency index was 0.035647 (0.035647), the retention index was 0.628290 (0.628290), and the composite index was 0.022397 (0.022397) for all sites and parsimony-informative sites. This analysis involved 549 nucleotide sequences. Codon positions included were 1st+2nd+3rd+Noncoding. There were a total of 285 positions in the final dataset.

b. Organisms responsible for the hydrogenotrophic pathway

An analysis of profiles annotated to formylmethanofuran dehydrogenase subunits A, C and E (*fmdACE*) was done since *fmd* acts as an indicator of hydrogenotrophic pathway. There was no significance differences in the abundance of hits at $p < 0.05$ level for the four samples ($F(3, 364) = 1.393$, $p = 0.2447$). More hits were recorded in samples 1c (796) followed by sample 1b (793) drawn from lagoon 1. Lagoon 2 samples recorded lower hits: 2c (671) and 2a (329).

In accordance with taxa, sample 2c was richer with a score of 67, followed by 1c (65), 1b (59) and the lowest was sample 2a with a score of 44. Sample 2c consortium was the most diverse (Shannon–Wiener index—3.203) while sample 2a was the least diverse (Shannon–Wiener index—3.203). Nevertheless, the organisms recorded a lower evenness with sample 2a having a Pielou index 0.4431, 2c (0.3672), 1b (0.3578) and the lowest even was sample 1c (0.3047) as shown in Table 20.

Table 19: Diversity indices of profiles annotated to *fmd* gene

	Sample 2a	Sample 2c	Sample 1c	Sample 1b
Taxa_S	44	67	65	59
Hits	329	671	796	793
Dominance_D	0.08683	0.07	0.095	0.08378
Simpson_1-D	0.9132	142	77	0.9162
Shannon_H	2.97	0.92	0.904	3.05
Evenness_e^H/S	0.4431	86	2	0.3578
Fisher_alpha	13.65	3.20	2.986	14.74
Berger-Parker	0.2036	3	0.304	0.1866
		0.36	7	
		72	16.74	
		18.5	0.218	
		2	6	
		0.17		
		44		

Bray-Curtis similarity index recorded a higher similarity score of 91% between the microbial consortium of samples 1b and 1c probably because they belonged to the same lagoon. Sample 2a was 65% similar to sample 2c even though they came from the same lagoon. The lowest similarity score was between samples 2a and 1b at 49% (table 21)

Table 20: Bray-Curtis similarity index among the samples as annotated by *fmd*

Samples	2a	2c	1c	1b
2a	100%	65%	51%	49%
2c	65%	100%	59%	60%
1c	51%	59%	100%	91%
1b	49%	60%	91%	100%

The *fmd* profiles were mainly from the archaea (90.17%). Among the archaea, *Methanosarcina* (32%) and *Methanothermobacter* (27%) dominated sample 1b consortium. A similar scenario was observed in sample 1c with *Methanothermobacter* (31%) and *Methanosarcina* (29%). Sample 2c was dominated by *Methanobrevibacter* (20%) while *Methanoregula* (13%), *Methanosarcina* (12%) and the *Methanobrevibacter* (11%) were the subdominant genera. Sample 2a was similar to 2c with *Methanospirillum* (22%),

Methanosarcina (18%), *Methanoregula* (14%), and the *Methanothermobacter* (11%) as shown in fig. 34. Fig 35 gives a summary of abundance of hydrogenotrophic archaea community in the four samples.

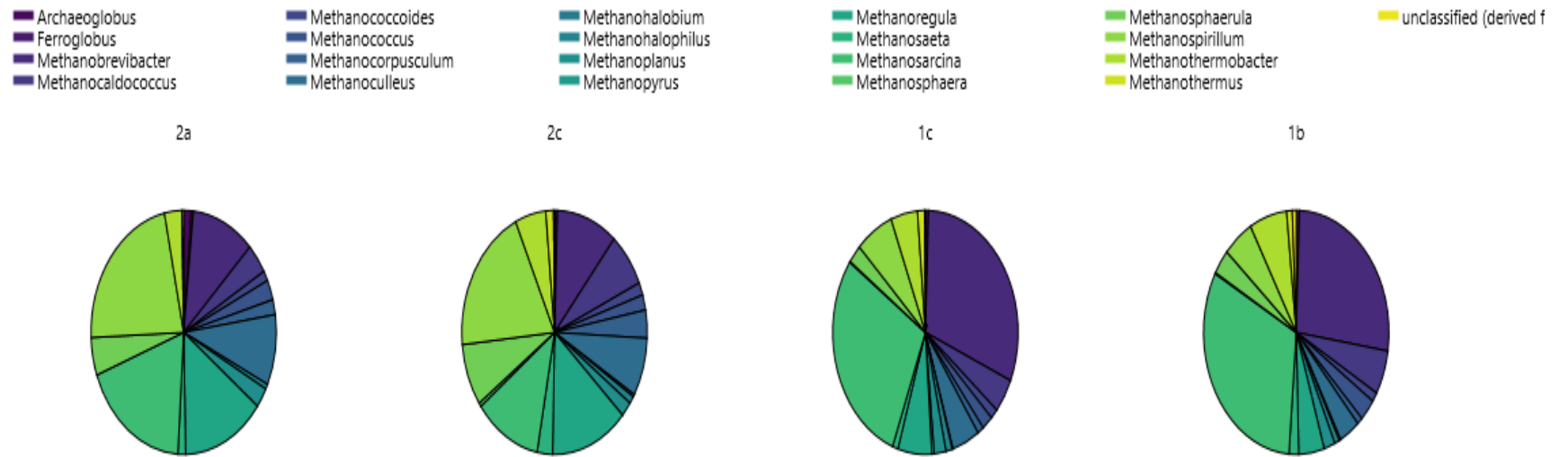

Figure 34: Genera composition of archaea profiles from fmd annotation

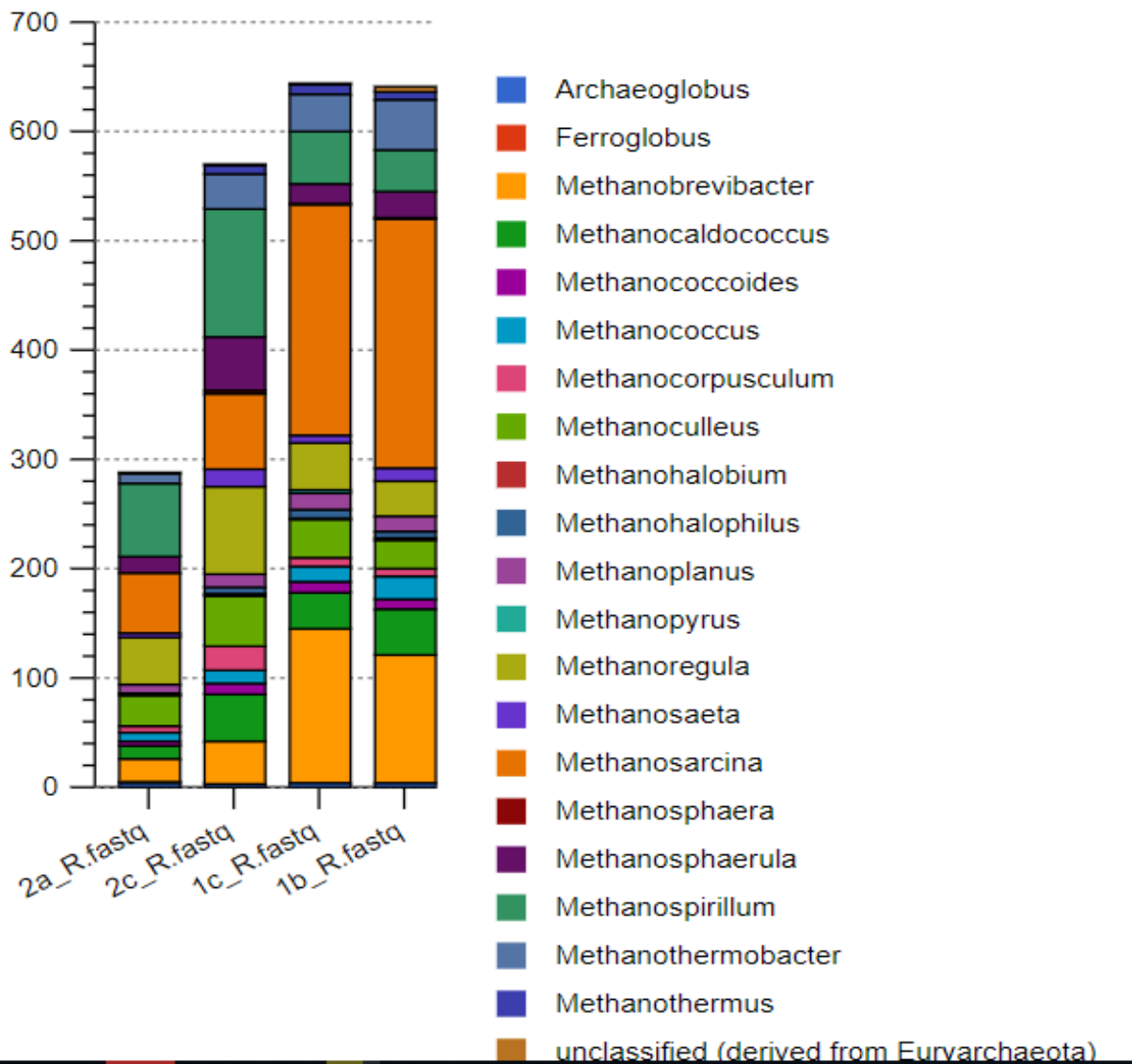

Figure 35: Abundance of the different genera of archaea in the hydrogenotrophic

Among the bacteria, the *Nitrosococcus* (22%) dominated sample 1b bacterial consortium. *Caldocellulosiruptor* (9%), *Methylococcus* (7%), *Methylocella* (7%) and *Methylobasillus* (6%) dominated sample 1c bacterial community. *Caldocellulosiruptor* (9%) and *Desulfurivibrio* (10%) were the dominant bacterial groups in sample 2c consortium. Halanaerobium (17%) was dominant in sample 2a while *Desulfovibrio* (14%) and *Desulfatibacillum* (10%) were the subdominant groups (Fig. 36). Fig. 37 summarizes all the hydrogenotrophic microbes as annotated by the fmdACE genes for the bacteria genera.

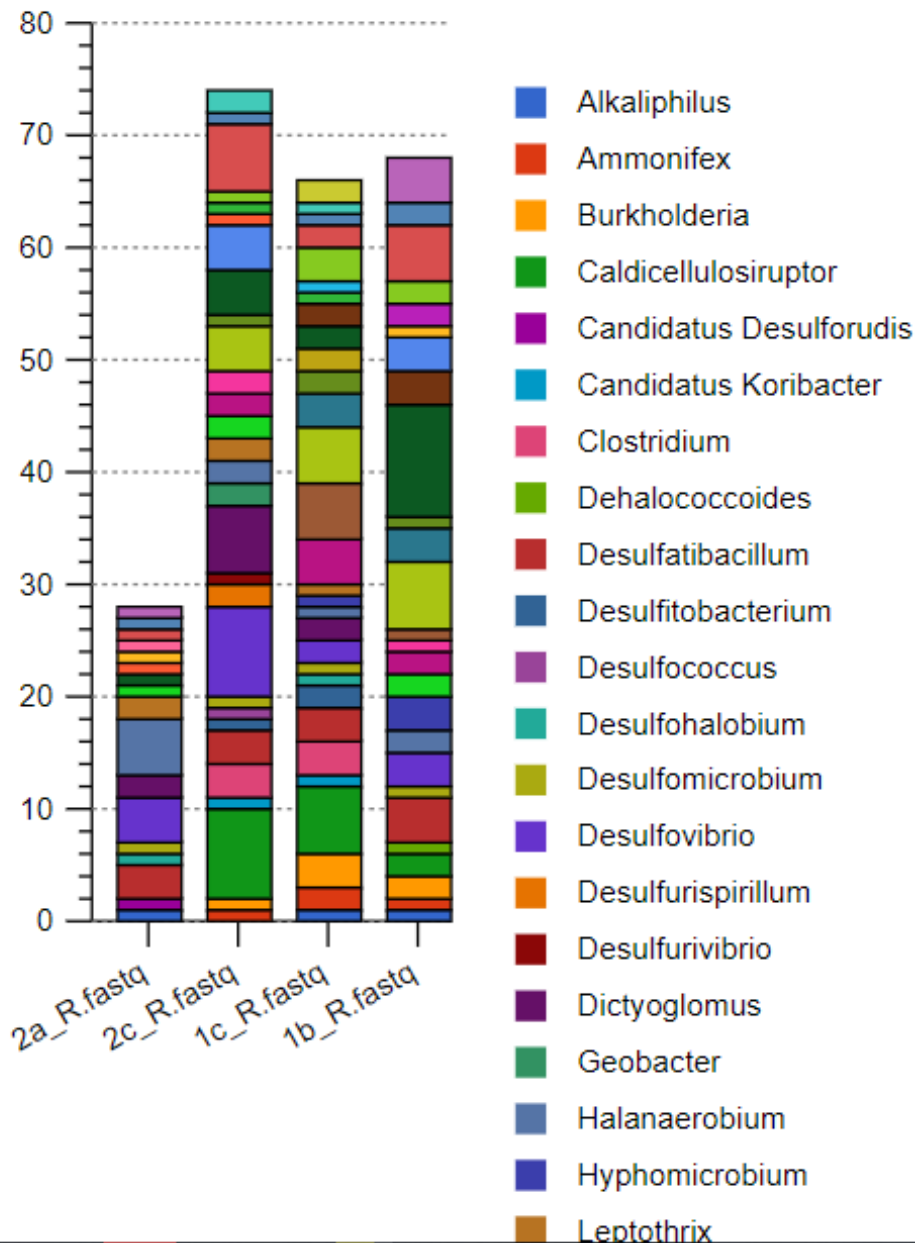

Figure 37: Abundance of the different genera of bacteria in the hydrogenotrophic pathway

The archaeal species dominated in all the samples with *Methanobrevibacter smithii* (19%, 22%) *Methanosarcina berkeri* (16%) in samples 1b and 1c respectively while *Methanospirillum hungatei* (17%, 20%) and *Methanoregula boonei* (12%, 13%) dominated in samples 2c and 2a respectively.

Phylogenetic tree for archaea and bacteria in the hydrogenotrophic pathways.

The Maximum Parsimony for lagoon 1 had parsimonious tree length of 38759 as shown

(<https://www.dropbox.com/s/jkmox3cw2nb2ccc/Lagoon%201%20hydrogenotrophic%20pathway%20phylogenetic%20tree.pdf?dl=0>). The consistency index was 0.021595 (0.021368),

the retention index of 0.519311 (0.519311), and the composite index of 0.011215 (0.011097) for all sites and parsimony-informative sites. This analysis involved 732 nucleotide sequences. Codon positions included were 1st+2nd+3rd+Noncoding. There were a total of 288 positions in the final dataset.

Lagoon 2 had parsimonious tree with length of 37141 as shown (<https://www.dropbox.com/s/3c553lksnij09d9/Lagoon%20%20hydrogenotrophic%20pathway%20phylogenetic%20tree.pdf?dl=0>). The consistency index was 0.022670 (0.022670), the retention index was 0.502958 (0.502958), and the composite index was 0.011402 (0.011402) for all sites and parsimony-informative sites. This analysis involved 654 nucleotide sequences. Codon positions included were 1st+2nd+3rd+Noncoding. There were a total of 288 positions in the final dataset.

c. Organisms responsible for the acetoclastic pathway

In order to identify microorganisms involved in the acetoclastic pathway, an analysis of phylogenetic assignments of the D subunit of Carbon monoxide dehydrogenase/acetyl-CoA synthase (*cdhD*) was done as it is directly involved in the transmission of a methyl group from acetate during acetoclastic methanogenesis (Thauer *et al.*, 2008).

When considering species dominance, the highest D value was recorded in sample 1c (0.7033) followed by 1b (0.5674), 2c (0.2471) and the lowest was sample 2a (0.1919). The trend in D values was the same as the total number of hits as lagoon 1 recorded higher values compared to lagoon 2. Nonetheless, sample 2a consortium was the most diverse and even (Shannon–Wiener index—2.142, Pielou index 0.5677), with 2c recording Shannon–Wiener index of 2.064 and Pielou index 0.3581). Samples 1b recorded Shannon–Wiener index of 1.268, and Pielou index 0.187. The trend here is that samples in lagoon 2 were the most diverse and even compared to samples in lagoon 1 (see Table 22).

Table 21: Diversity indices for cdh profiles

	Sample 2a	Sample 2c	Sample 1c	Sample 1b
Taxa_S	15	22	19	19
Hits	76	162	351	205
Dominance_D	0.1919	0.2471	0.7033	0.5674
Simpson_1-D	0.8081	0.7529	0.2967	0.4326
Shannon_H	2.142	2.064	0.8942	1.268
Evenness_e^H/S	0.5677	0.3581	0.1287	0.187

When considering taxa in the *cdh* profiles, sample 2c consortium recorded the highest richness with a score of 22, with the lowest recorded in sample 2a with a score of fifteen 15. Lagoon 1 samples recorded the same score of 19. Nevertheless, the highest number of total hits was recorded in samples from lagoon 1 with 1c recording 351 hits while 1b had 205 hits. Lagoon 2 samples had 162 hits (2c) while the lowest hits were recorded in 2a (76) as shown in Table 22. Test to compare the means of the abundance between the four samples revealed no significant difference between the samples ($F_{(3, 104)}=0.4574$, $p=0.7123$) as shown in Table 234.

Table 22: ANOVA test for the cdh profiles

Test for equal means

	Sum of sqrs	Df	Mean square	F	p (same)
Between groups:	1468.04	3	489.346	0.4579	0.7123
Within groups:	111153	104	1068.77		
Total:	112621	107	0.916		

Bray-Curtis similarity index recorded a higher similarity score between samples 1b and 1c. the profiles in lagoon 2a were 60% similar to that of 2c. The lowest similarity was recorded in between sample 2a and 1c at 28%. Sample 2c was 42% like sample 1c (Table 24).

Table 23: Bray-Curtis similarity index for *cdh* profiles in the different samples

	2a	2c	1c	1b	1b
2a	100%	60%	28%	43%	43%
2c	60%	100%	42%	59%	59%
1c	28%	42%	100%	70%	70%
1b	43%	59%	70%	100%	100%

The *cdh* consortium structure was made up of archaea (8.79%) and bacteria (91.21%). Only two genera of archaea were recorded in the *cdh*-annotated profiles with one *Methanocaldococcus* recorded sample 2c only. The *Methanoregula* dominated in all the samples 2a, 2c, 1c and 1b (Fig. 38). Fig. 39 summarizes the acetoclastic archaea in the samples.

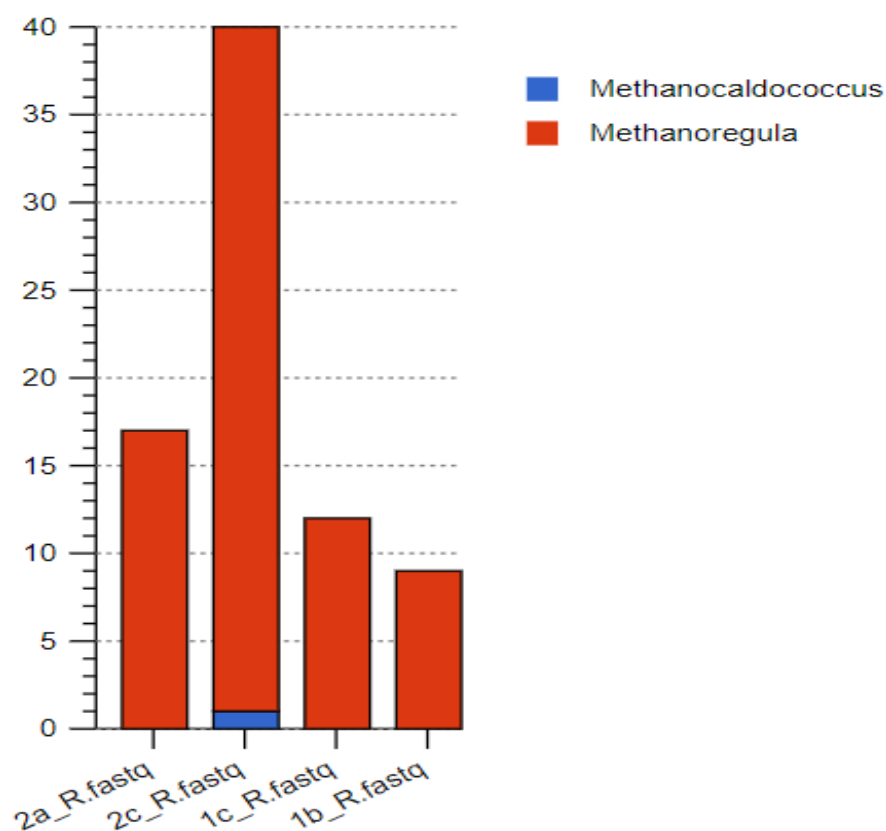

Figure 38: Abundance of the different genera of archaea in the acetoclastic pathway

■ Methanocaldococcus
■ Methanoregula

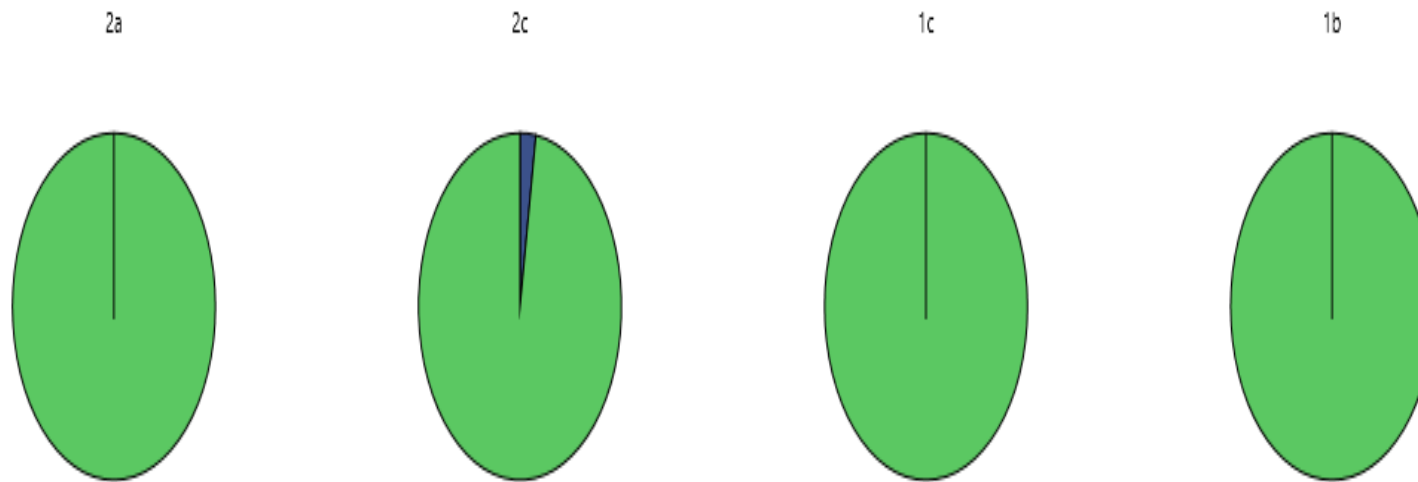

Figure 39: Composition of archaeal cdh-annotated profiles in the composite samples

Among the acetoclastic bacterial consortium, *Clostridium* dominated in the entire sample with 79%, 88%, 57% and 47% in samples 1b, 1c, 2c and 2a respectively (see Fig.40). Fig. 41 summarizes the acetoclastic bacteria in the sample.

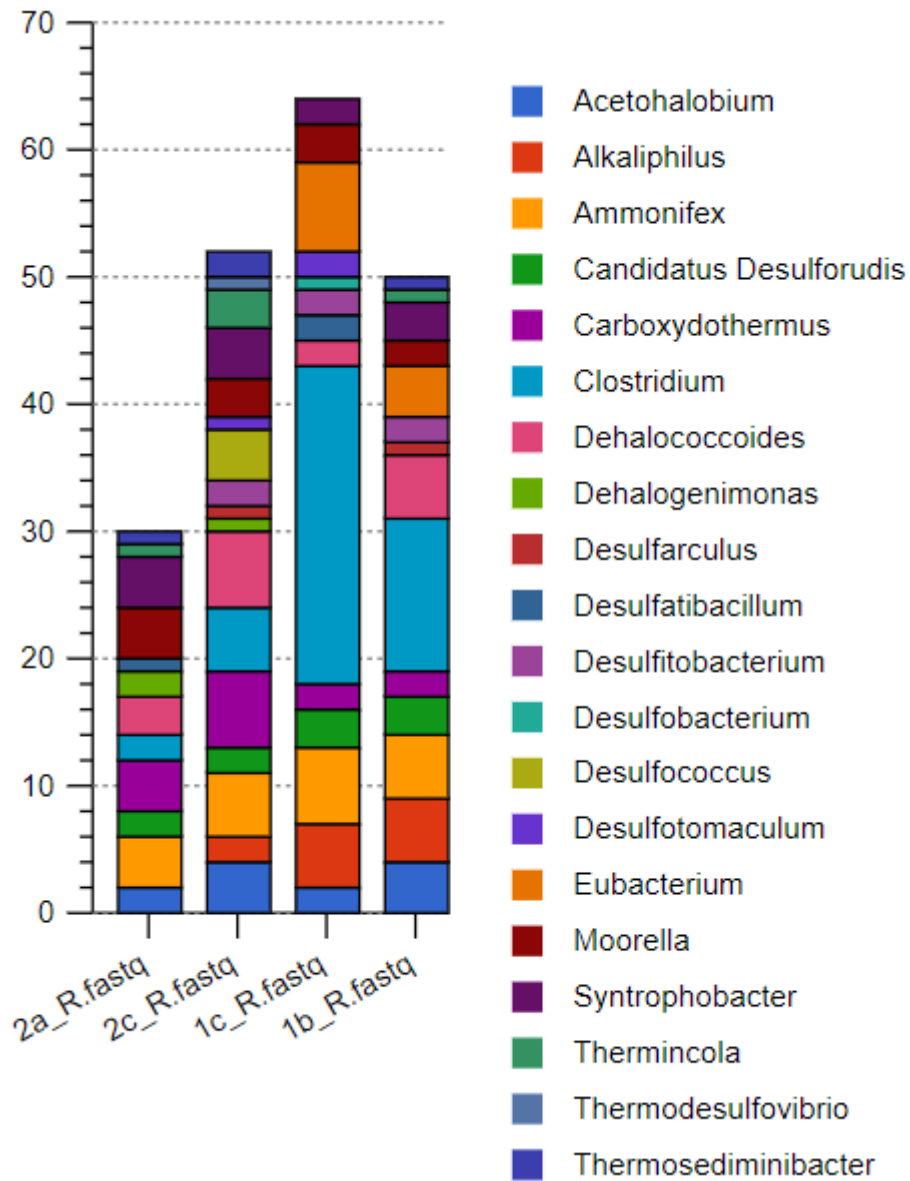

Figure 40: Abundance of the different genera of bacteria in the acetoclastic pathway

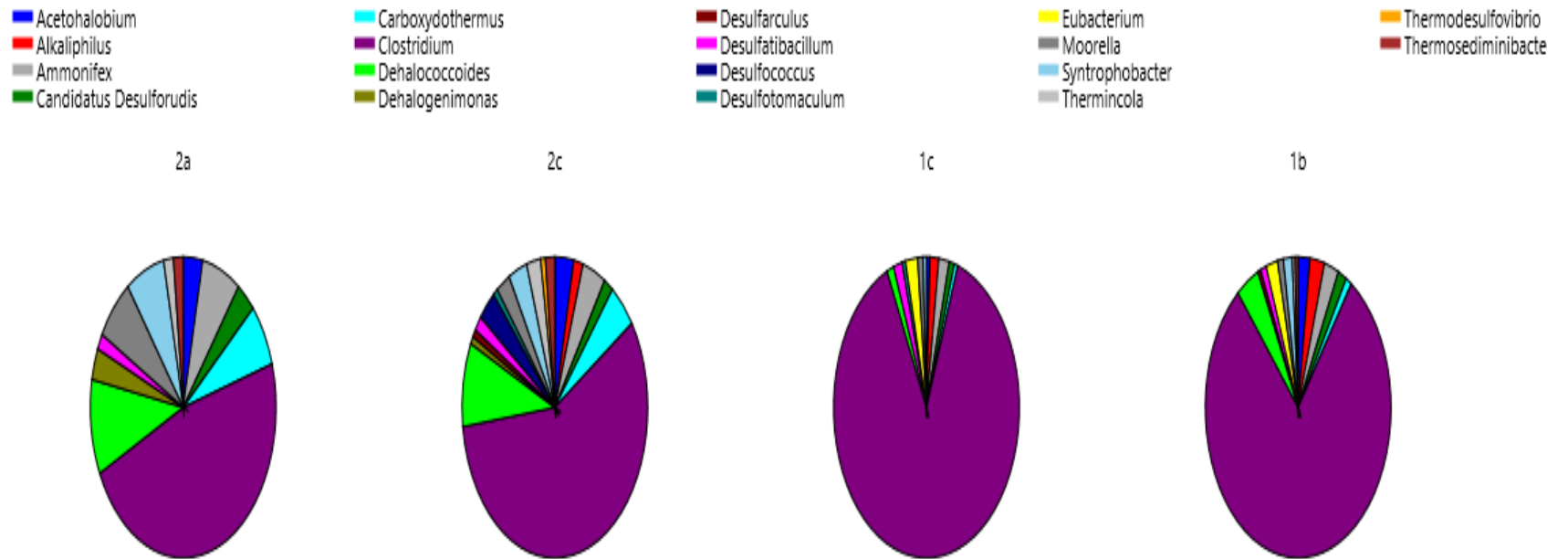

Figure 41: Composition of bacterial cdh-annotated profiles in the four samples

Species *Clostridium difficile* was the most abundant at 79% in sample 1b and 84% in sample 1c. *Clostridium difficile* also dominated in sample 2c (43%) and 2a (37%) with *Methanoregula boonei* forming the subdominant group at 24% in sample 2c and 22% in sample 2a.

Phylogenetic tree for archaea and bacteria in the acetoclastic pathways.

The evolutionary history was inferred using the Maximum Parsimony method. The most Lagoon 1 had a parsimonious tree with length 4352 as shown (<https://www.dropbox.com/s/bggb8k8trku2rh4/lagoon%201%20acetoclastic%20pathway%20phylogenetic%20tree.pdf?dl=0>). The consistency index was 0.170037 (0.168891), a retention index of 0.524549 (0.524549), and the composite index of 0.089193 (0.088592) for all sites and parsimony-informative sites. This analysis involved 82 nucleotide sequences. Codon positions included were 1st+2nd+3rd+Noncoding. There were a total of 276 positions in the final dataset.

Lagoon 2 on the other hand, had a parsimonious tree with length of 6532 as shown (<https://www.dropbox.com/s/da975hzbpj8tzhb/Lagoon%202%20acetoclastic%20pathway%20phylogenetic%20tree.pdf?dl=0>). The consistency index was 0.115279 (0.112834), the retention index was 0.474684 (0.474684), and the composite index was at 0.054721 (0.053560) for all sites and parsimony-informative. This analysis involved 105 nucleotide sequences. Codon positions included were 1st+2nd+3rd+Noncoding. There were a total of 285 positions in the final dataset.

d. Organisms responsible for the methylotrophic pathway

Utilization of methanol or methylamines is the third commonly recognized methanogenic pathway, which contains genes of methanol and mono-, di- and trimethylamine methyltransferases (*mta*, *mtm*, *mtb*, *mtt*, respectively). Comparison of the available domain profile sequences of *mtaB*, *mtmB*, *mtbB* and *mttB* showed that their abundances were high in sample 1c with 34% of the total hits followed by sample 1b (32%), 2c (25%) and the least in 2a (9%). The hits in this category were composed of bacteria (3%) and archaea (97%).

Analysis of variance (ANOVA) was carried out to compare the differences in the means of the abundances if profiles in the different sampling point and there was significant difference ($F(3, 208) = 3.3103$, $P = 0.02763$ between the samples at $p > 0.05$ (see Table 25).

Table 24: ANOVA analysis for methylotrophic pathway profiles

Test for equal means						
	Sum	Df	Mean	F	p	
	of sqrs	square				
Between	2247.4	3	749.13	3.10	0.0276	
groups:	1	20	7	3	3	
Within	50217.	8	241.43			
groups:	5	21	0.0251			
Total:	52464.	1	9			
	9					

A post hoc test was carried out to determine which samples were significantly different from each other and significant differences was noted between sample 2a and 2c, 2a and 1c, 2a and 1b while all the other samples reported no significant differences (see Table 26).

Table 25: Dunn's post hoc test for the *methylotrophic pathway*' profiles

	2a	2c	1c	1b
2a		0.04315	0.00407	0.006088
2c	0.04315		0.3951	0.471
1c	0.00407	0.3951		0.8968
1b	0.006088	0.471	0.8968	

Taxa richness was higher in sample 1c with a score of 43 and lowest in 2a with a score of 31. Generally, dominance was low across the samples with a D value ranging between 0.07018 to 0.07672 with the highest in 2c and lowest in sample 1b. The most diverse consortium was in sample 1b (Shannon–Wiener index—3.022) and 1c (Shannon–Wiener index—3.006). Despite sample 2a being the least diverse (Shannon–Wiener index—2.958), it was the most even consortium with Pielou index of 0.6215 while the least even was sample 1c with the Pielou index of 0.4697 (Table 27).

Table 26: Diversity indices for methylotrophic pathway' profiles

	Sample 2a	Sample 2c	Sample 1c	Sample 1b
Taxa_S	31	38	43	41
Individuals	166	439	601	575
Dominance_D	0.07579	0.07672	0.07115	0.07018
Simpson_1-D	0.9242	0.9233	0.9289	0.9298
Shannon_H	2.958	2.98	3.006	3.022
Evenness_e^H/S	0.6215	0.5179	0.4697	0.5008
Equitability_J	0.8615	0.8191	0.7991	0.8138
Fisher_alpha	11.24	9.984	10.6	10.1

Among the archaea, the most dominant group was the *Methanosarcina* (21%) while *Methanobrevibacter* (19%), *Methanothermobacter* (18%) and *Methanosaeta* (15%) were subdominant groups in sample 1b. the same trend is seen in sample 1c with *Methanosarcina* (29%), while *Methanobrevibacter* (15%), and *Methanothermobacter* (15%) forming the sub dominant groups. For the lagoon 2 samples, *Methanoregula* (18%), *Methanosarcina* (16%) and *Methanospirillum* (15%) dominated sample 2c consortium while *Methanosarcina* (22%), *Methanosaeta* (15%), *Methanoregula* (15%), and *Methanospirillum* (13%) were the domiant group in sample 2c archaeal community (Fig. 42). Fig. 43 summarizes the methylotrophic archaea in the samples.

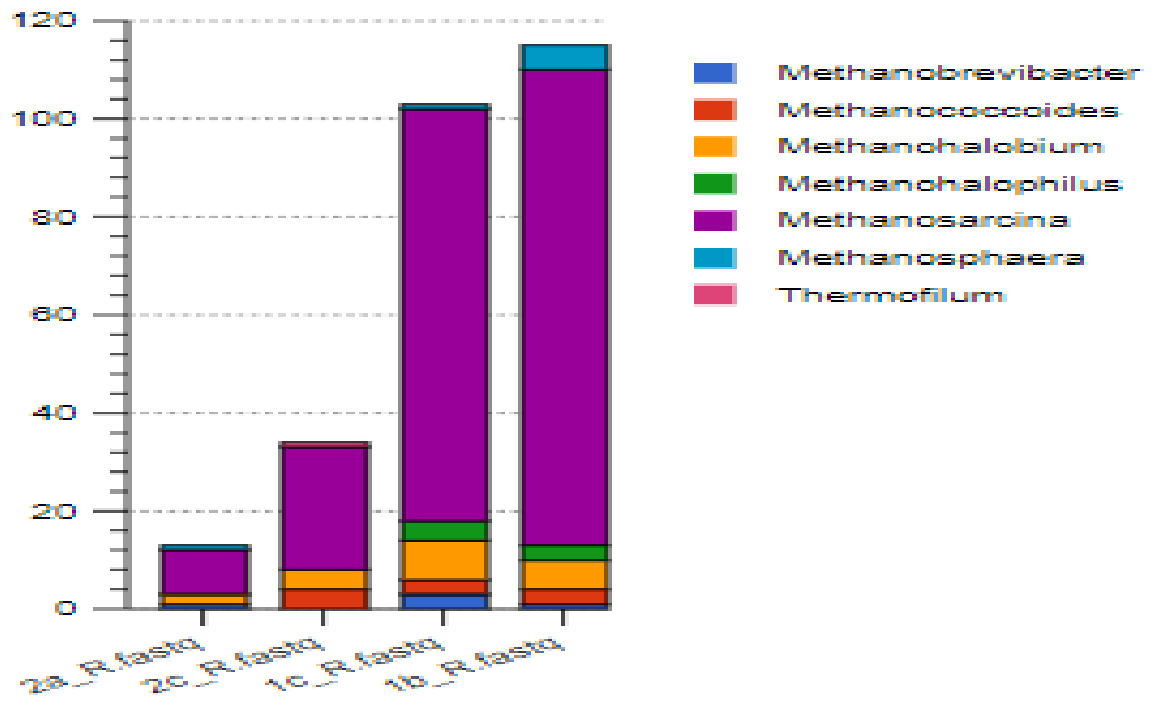

Figure 42: Abundance of the different genera of archaea in the methylotrophic pathway

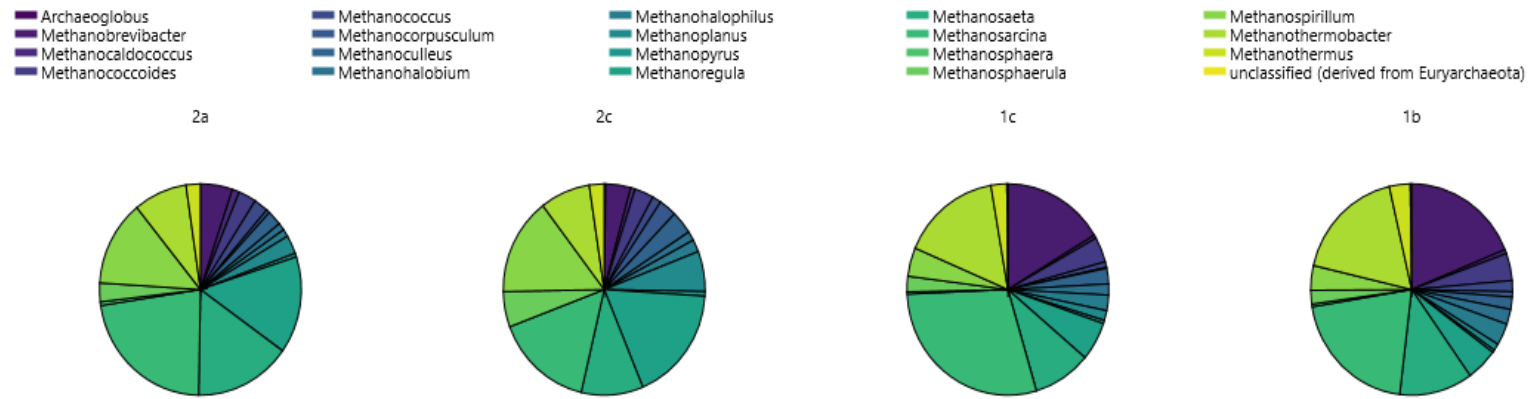

Figure 43: Composition of the archaea community in the methylotrophic pathway' profiles

The *Nitrosococcus* (33%) and the *Methylococcus* (33%) dominated the bacterial community in sample 1b. The *Methylococcus* (31%) and *Methylobacterium* (31%) dominated sample 1c consortium. In lagoon 2, *Thermincola* (25%), *Methylobacterium* (25%), *Burkholderia* (13%) and *Methylovorus* (13%) dominated in sample 2c. *Methylococcus* were the only group found in sample 2a (Fig. 44). Fig. 45 summarizes all the methylotrophic bacteria in the different samples.

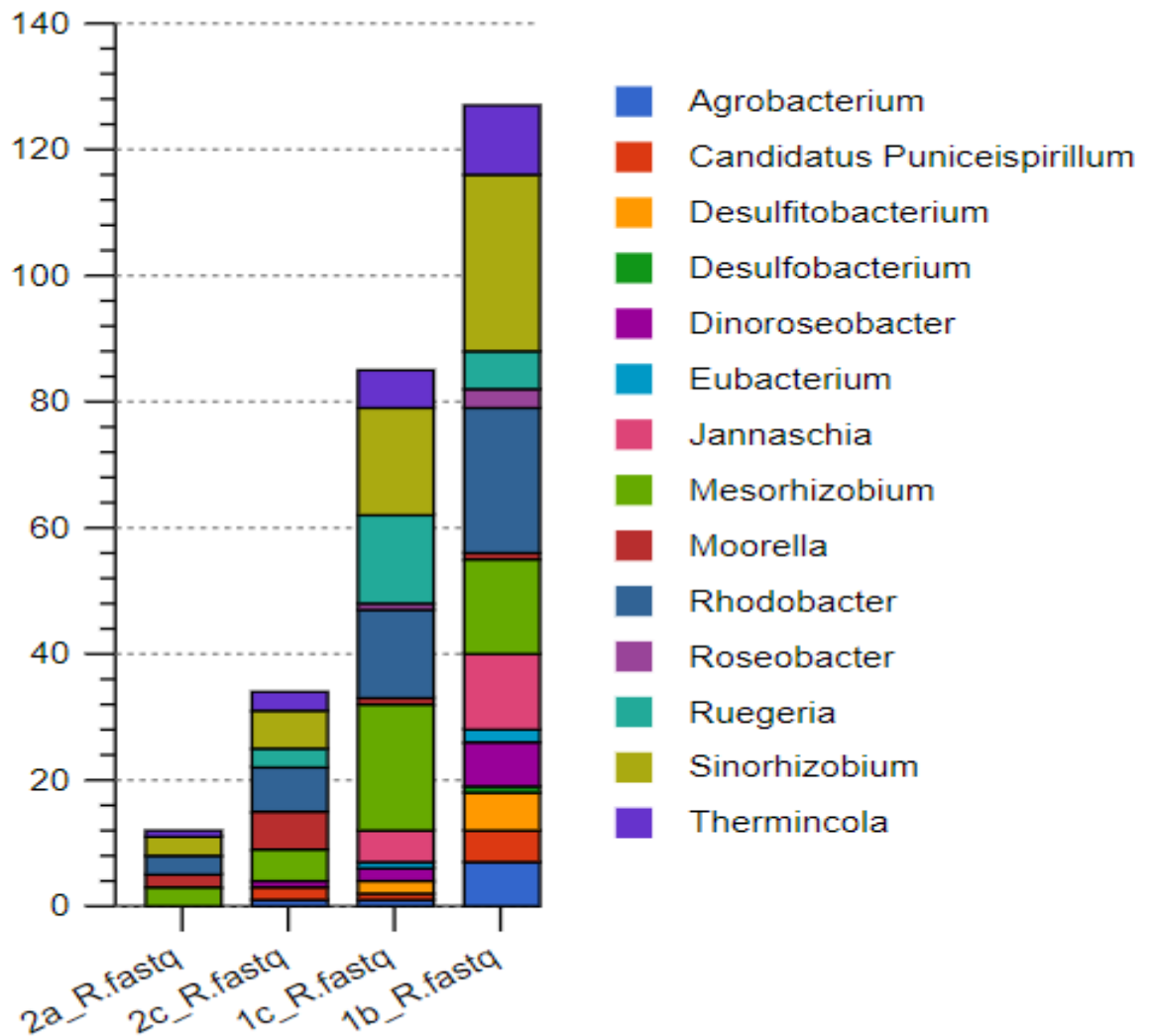

Figure 44: Abundance of the different genera of bacteria in the methylotrophic pathway

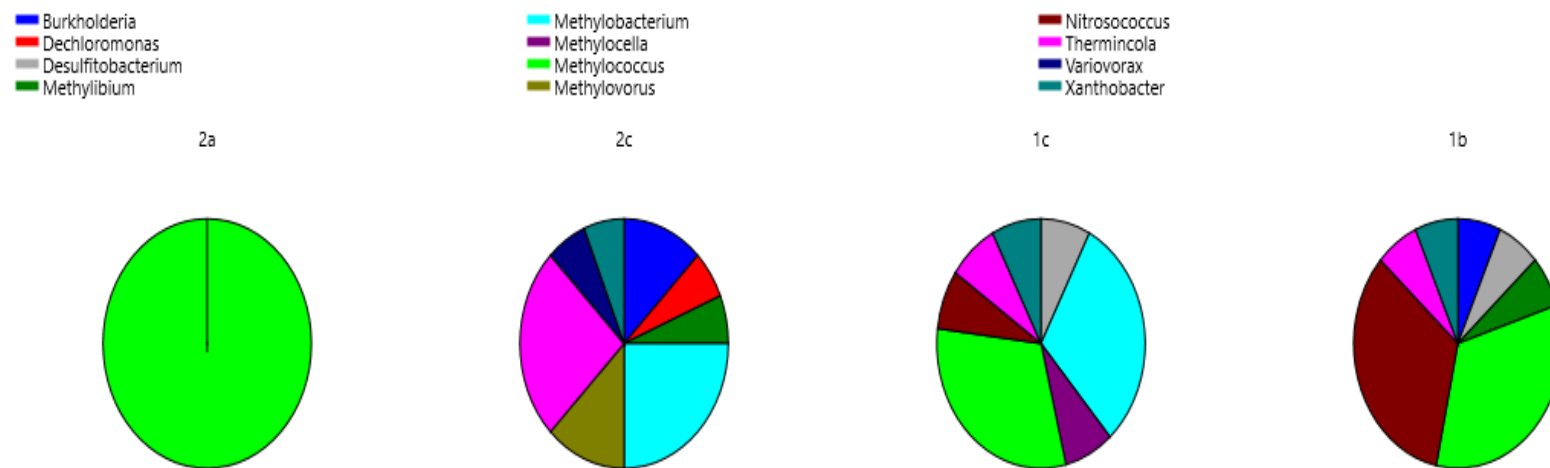

Figure 45: Composition of the bacterial community in the methylotrophic pathway' profiles

Methanosarcina barkeri (14%, 15%) and *Methernothermobacter themeratotropicus* (13%, 13%) were the most abundant in sample 1b and 1c respectively. *Methanoregula boonei* (15%, 16%) and *Methanospirillum hungatei* (14%, 14%) were the dominant groups in lagoon 2 (samples 2c and 2b respectively).

Phylogenetic tree for archaea and bacteria in the methylotrophic pathways.

Lagoon 1 had a parsimonious tree with length 17229 as shown in the link; (<https://www.dropbox.com/s/e34ne66m1bu00k9/Lagoon%201%20methylotrophic%20phylogenetic%20tree.pdf?dl=0>). The consistency index was 0.049103 (0.048827), the retention index was 0.452842 (0.452842), and the composite index was 0.022236 (0.022111) for all sites and parsimony-informative sites. This analysis involved 283 nucleotide sequences. Codon positions included were 1st+2nd+3rd+Noncoding. There were a total of 291 positions in the final dataset.

The evolutionary history was inferred using the Maximum Parsimony method. The most Lagoon 2 had parsimonious tree with length 4686 as shown in the link; (<https://www.dropbox.com/s/qwub3ub026g49nc/Lagoon%202%20methylotrophic%20pathway%20phylogenetic%20tree.pdf?dl=0>). The consistency index was 0.164319 (0.161277), the retention index was 0.440811 (0.440811), and the composite index was 0.072434 (0.071092) for all sites and parsimony-informative sites. This analysis involved 72 nucleotide sequences. Codon positions included were 1st+2nd+3rd+Noncoding. There were a total of 279 positions in the final dataset.

CHAPTER FIVE

DISCUSSION

5.1 Physicochemical properties of sewage sludge

The sludge in the Nyeri-Kangemi Wastewater treatment plant marked variations in the physicochemical parameters between the sludge tanks and the dry beds. Physicochemical parameters are important because they affect the suitability for beneficial use of sludge, especially in agriculture. These are assessed by measuring the organic content, toxic organics, metals, nutrients, and pathogens. The trace element concentrations and availability of N, P, and K nutrients influence the sludge applicability as a soil conditioner (Malack *et al.*, 2008).

In the Nyeri-Kangemi wastewater treatment plant, the temperature was relatively higher in the sludge tanks than in the dry beds but within the recommended limits by Environmental Management and Coordination (Water Quality) Regulations 2006. The significantly higher temperature ($23.13 \pm 0.15^{\circ}\text{C}$) compared to the dried product sludge used as fertilizer ($21.03 \pm 0.06^{\circ}\text{C}$). The relatively higher temperatures of the liquid raw sludge received at the sludges tank may be attributed to exothermic digestion processes as microorganisms present actively metabolize the biodegradable and readily available organic matter, releasing heat in the process (Sweeten, 2008). Dubey *et al.* (2021) report that sorption of some emerging contaminants (EC) such as 17- α ethinylestradiol (EE2) in activated sewage sludge is an exothermic process through both physisorption and chemisorption. This suggests that the sorption mechanism of substrates and ECs in the liquid raw sludge is the reason for the higher temperatures of the liquid sludge. Nevertheless, the temperature was within the standard limit for sludge discharge and agricultural use.

The particle density recorded in both the sludge tanks and the dry bed was ten (10) times more than the bulk density recorded in the raw sewage (Table 1). The lower bulk density values in the raw sludge could be attributed to water vapour, void volume, and some gases that significantly lower the density in the sludge tank (El-Nahhal *et al.*, 2014). Kelly (2005) recorded similar values when investigating the specific gravity of solids in digested sludge material, where the bulk density ranged between 1.55 g/cm^3 and 1.72 g/cm^3 . The density of the investigated sludge suggested that the samples contained very high fractions of solid materials, and the mechanical analysis of sludge texture suggested the solid materials were mainly sand, as shown in Table (3). The sandy nature indicates a high porosity of the sludge. This is similar to values reported by Ruan and Liu (2013), who found a high porosity (78%) in the structure of activated sludge. They attributed this to the fact that sludge may

comprise different layers with different sizes, spaces, and pores that enable a higher void volume.

The moisture content in the dry bed was low due to the loss of water through the dewatering processes involving evaporation into the atmosphere and infiltration through the spaces between the concrete slabs on the floor of the dry beds. These results are similar to those of Al-Malack *et al.* (2008) in their investigation of the Physico-chemical characteristics of municipal sludge produced in three major cities in the eastern province of Saudi Arabia. They found that the initial moisture contents of the sludges for the wastewater treatment plants were in the range of 95 - 97 % and 13 – 45 % for the dried sludge samples.

The total solids (TS) and the volatile solids (VS) significantly increased in the sludge tank and the dry bed, respectively ($12.66 \pm 0.48\%$ to $53.40 \pm 8.82\%$ for TS and $11.22 \pm 0.09\%$ to $29.79 \pm 9.94\%$ for VS). This increase in the values of TS and VS after dewatering agrees with the study by Douglas *et al.* (2021), where there was a significant increase of TS of sludge samples from pit latrine during the dry season. Al-Malack *et al.* (2008) also recorded an increase in the VS from 51%, 51%, and 53% to 65%, 62%, and 66% at the sludge tank, lagoons, and the dry beds, respectively. This can be attributed to infiltration evaporation, weathering effects and biodegradation activities that help in the dewatering processes and therefore increase the concentration of the remaining solids in sludge (Doglas *et al.*, 2021).

The pH of both the raw and dried sludge shifted towards neutrality, which was within the range of 5.5 to 9.5 recommended for agricultural land application (Badza *et al.*, 2020). This change in pH may be attributed to evaporation and weathering effects in the dry beds, increasing the sludge's ion concentration (Sweeten, 2008). The relatively low pH value in the sludge tank can be attributed to nitrate formation, leading to the release of hydrogen ions during the nitrification process (Cáceres *et al.*, 2018). The increase in pH in the dry sludge may also be attributed to a loss in concentration of the acetic acid and other acidic molecules during and after anaerobic processes, as observed in others in Schifman *et al.* (2018). Nevertheless, it is essential to note that even though the nitrate component was not analyzed in this study, generally, the nitrification process causes the oxidation of ammonia to nitrates, which lowers the pH of the raw sludge in the sludge tank (Bozym & Siemiatkowski, 2018).

Sludge from both the sludge tank and the dry beds had high electrical conductivity (EC) that indicated a high concentration of organic and inorganic ions in the sludge and, therefore, high salinity (Suanon *et al.*, 2016). Therefore, this high EC indicates that the sludge is not ideal for application to all crops unless with the addition of a neutralizer. In other studies, it was found that EC values of 2.5 – 3.0 mS/cm are harmful to fruit crops (Khadra *et*

al., 2019), and EC values of 4.5 – 5 mS/cm are harmful to stem crops as they lower their germination rates and causes plant withering (Suanon *et al.*, 2016). As such other alternative sludge products can be made.

The total organic carbon exhibited high values, which could be attributed to the fact that the total organic matter was significantly low ($4.27 \pm 0.05\%$ in the sludge well and $3.42 \pm 0.05\%$ in the dried sludge). Sewage sludge is considered a rich source of organic matter and is therefore considered a good soil conditioner (Badza *et al.*, 2020). Nevertheless; this is primarily true for sludge with an organic matter content of above 50%. The organic matter content of the investigated dry sludge was less than the optimal 5% to 6% used for agricultural soils, indicating that it is not very good for use as a soil ameliorant (Badza *et al.*, 2020).

According to Srinivasarao *et al.* (2015), the phosphorous level in the sludge between 0 - 20 mg/l is considered a phosphorus deficiency, while 20 – 80 mg/l phosphorus is sufficient and above 80 mg/l is a high phosphorus level. The sludge from Kangemi WWTP exhibited very high levels of total organic phosphorus at 91.67 ± 1.25 mg/l in the sludge well and 88 ± 1.63 mg/l in the dry bed. On the other hand, the total organic nitrogen level was significantly low and showed minimal variation between the sludge tank and the dry bed. These low values of total organic nitrogen may be due to the degradation of organic components in the anaerobic digestion process (Singh *et al.*, 2017). These results are similar to those of Badza *et al.* (2020). They investigated the sludge characteristics of anaerobic and aerobic digesters and found 1.4% and 4.1% total organic nitrogen, respectively, suggesting that the sludge was well nitrified.

The concentration of these essential metals in the sludge tank followed the following order from the highest to the lowest; Ca>Na>K>Mg>Fe>Mn>Zn>Cu, while in the dry bed samples, it was; Fe>Ca>Mg>Mn>K>Na>Zn>Cu which is similar to results reported by Jodral-Segado *et al.*, (2006). The high calcium concentration in the sludge was attributed to lower levels of pH in the sludge. Sodium, K, Mg, and Fe recorded in the dry sludge samples are readily available in sludge as exchangeable ions. Therefore, the lower acidity recorded in this study means only a few hydrogen ions are available, allowing more metal ions to occupy the remaining exchange sites in sludge (Chimdi *et al.*, 2012; Segado *et al.*, 2006). The low concentrations of Zn and Cu recorded in both the sludge tank and the dry beds samples may be due to high levels of carbonates in the sludge (Santos *et al.*, 2010). There were high metal concentration levels in the dry bed samples compared to the sludge tank samples. Barraoui *et al.* (2021) recorded a similar trend. They explained that this was possibly due to the anaerobic

digestion process between the two sites leading to more than tenfold increases in the concentration. Similar increases in the metal concentrations in the dry sludge were also reported by Shrivastava *et al.* (1998) and Ajeej *et al.* (2015). Iron, manganese, and total phosphorous in the dry sludge exceeded the standard limits for discharge into the environment.

5.2 Physicochemical parameters of the sludge digestion tanks

The anaerobic digestion tanks represented by lagoons 1 and 2 at different processing stages at the time of sampling were the leading sites for biochemical decomposition of the organic waste by various microbial activities in the absence of oxygen (Bano *et al.*, 2017). It is critical to note that the total dry matter content, also referred to as Total Solids (TS), is found in these lagoons. Only the organic biodegradable fraction, also known as Volatile Solids, contributes to biogas production (Nong *et al.*, 2020). The volatile solids are typically used to characterize organic waste for anaerobic digestion. The TS range of a suitable bio-waste substrate is 70% to 95% (Vögeli, 2014). Substrates with VS below 60% are rarely considered valuable substrates for anaerobic digestion. The TS and VS recorded in this study were way below 60%, and therefore the need to introduce thickening sludge techniques such as gravity thickening, centrifugal thickening, Flootation thickening, and belt-type thickening to effectively increase TS prior to anaerobic digestion in the lagoons as far as targeting biogas production in the plant is concerned (Mathimani & Mallick, 2018).

The temperatures in lagoons 1 and 2 were slightly above 24°C. Even though this favors the growth of most bacteria, there is a need to keep the temperature either in the mesophilic range (30°C to 40°C) for the effective functioning of mesophilic bacteria or in the thermophilic range (45°C to 60°C) for effectiveness thermophilic microorganisms with an optimum temperature of 37°C or 55°C respectively (Vögeli, 2014). This can be done by installing heating systems or insulation of the lagoons (Bano *et al.*, 2017). Stiborova *et al.* (2015) recorded temperature in mesophilic sludge conditions (24-46°C) compared to thermophilic temperatures of 46-60°C to be the effective temperatures for biogas production in wastewater treatment plants. The mesophilic range may be the suitable approach because it is more stable; therefore, most microorganisms can tolerate it, and the slightly lower temperatures compared to the thermophilic range reduces inhibition of methanogenesis by ammonium as there is lower content of free ammonia at lower temperatures (Ryue *et al.*, 2019).

The pH recorded in lagoons 1 and 2 is within the optimum values for a stable anaerobic digestion process ranging between 6.5 to 7.5. Even though it is also important to

note that hydrolysis and acidogenesis thrive at an acidic pH of 5.5 to 6.5, while the methanogenic phase is at a pH of 6.5 to 8.2 (Vögeli, 2014). The oxidation-reduction potential (ORP) for optimum methane production by methanogens is between -175 mV and -400mV (Environmental, 2008). Other studies, such as Vongvichiankul *et al.* (2020), recorded ORP of -100 mV and -300mV as the required values for anaerobic digestion systems. The ORPs in lagoons 1 and 2 are within -50 mV and -250mV mV, which is within the denitrification and sulfide (H₂S) formation process (Environmental, 2008). This is further evidenced by the low total nitrogen levels in both lagoons 1 and 2, as outlined in table 4. The optimum ORP for acidogenesis and methanogenesis have been recorded at -284 mV and -336 mV, respectively (Vongvichiankul *et al.*, 2020).

Objective one (1) of this study was to determine the Physico-chemical characteristics of the sludge processed at the Nyeri wastewater and treatment plant in Kangemi, Nyeri County. In *situ* measurement and laboratory analysis of temperature, PH, DO, EC, ORP, and TS achieved the objective. VS, TC, TN, TP, Calcium (Ca), Sodium (Na), Potassium (K), Magnesium (Mg), Manganese (Mn), Zinc (Zn), Iron (Fe), and Copper (Cu). The data obtained was then tested for normality. The significant difference was determined using the t-test and Mann-Whitney U test and visualized using graphs and tables. This study investigated the sludge from the inlet, the concentration point in the sludge tank, and at the end of the process in the dry bed where sludge is collected for agricultural application. The investigations showed that the sewage sludge produced is slightly acidic and has high salinity making it unsuitable for agricultural application in some crops.

Further processing to neutralize salinity may be suitable. The organic matter was relatively low, and therefore the sludge is not a good soil ameliorant. The sludge contained a high fraction of solid materials and, therefore, a high porosity, making it suitable for irrigated agricultural land due to its high water holding capacity. The metal concentrations significantly increased in the dry bed sludge. Generally, the land application of the sludge from the Kangemi WWTP may lead to secondary pollution of iron, manganese, and phosphorus elements in the environment and, therefore, a negative impact on the receiving water bodies and their associated organisms. Bulk density, particle density, porosity, PH, DO, EC, ORP, and moisture were not significantly different, and therefore we accept hypothesis 1 for these parameters. We reject hypothesis 1 for Temperature, TS. VS, TC, TN, and TP since they showed significant differences between the sampling points.

Table 27: Biochemical reactions and their corresponding ORP values in wastewater sludge (Environmental, 2008).

Biochemical Reactions and Corresponding ORP Values	
Biochemical Reaction	ORP, mV
Nitrification	+100 to +350
cBOD degradation with free molecular oxygen	+50 to +250
Biological phosphorus removal	+25 to +250
Denitrification	+50 to -50
Sulfide (H ₂ S) formation	-50 to -250
Biological phosphorus release	-100 to -250
Acid formation (fermentation)	-100 to -225
Methane production	-175 to -400

The optimal C:N ratio for anaerobic digestion is between 16 and 25. The TOC and TN for both the lagoons are very low and therefore the C:N ratio is below 16, this means higher accumulation of ammonia but the fact that the pH is at 7.3-7.4 range, suggests that the lagoon environments were not that toxic for methanogens (Osagie, 2019). The optimum: N ratio can be achieved by mixing the sewage waste with materials that contains high C:N ratios such as organic solid wastes (Vögeli, 2014).

5.3 The sludge microbial communities

This study presents whole-genome shotgun metagenomic profiling of sewage sludge communities in the two lagoons at different sludge treatment stages. Lagoon 1 was at the initial stages of sludge digestion, while lagoon 2 had just completed the 4 months' digestion period and was set to be released into the drying beds. Our analysis demonstrated that some dominant groups were shared by the four composite samples but presented different abundances in lagoons 1 and 2. The analysis based on the RefSeq database further demonstrated that the abundance of different groups of microbes was significantly different between lagoons 1 and 2.

The MG-RAST pipeline to visualize the taxonomic richness and evenness of the composite samples collected did the rank abundance. Lagoon 1 was represented by composite samples 1b and 1c, while lagoon two was represented by composite samples 2a and 2c. In the rank abundance chart (see figures 18,19,20 and 21), the x-axis gives the abundance rank where the most abundant species is given rank 1, the second most abundant is 2, and so on. The y- axis represents the relative abundance; measured on a log scale, this is a measure of species abundance (e.g., the number of individuals) relative to the abundance of other

species. A steep gradient indicates low evenness as the high-ranking species have much higher abundances than the low-ranking species. A shallow gradient indicates high evenness, as the abundances of different taxa are similar taxa richness can be viewed as the number of different taxa on the chart (Saeedghalati *et al.*, 2017).

The results revealed that the sludge communities in the two lagoons are dominated by the bacteria domain, which is involved in organic matter degradation by organisms such as *Bacteroides* and *Clostridium*. Other studies (He *et al.*, 2017; Lim *et al.*, 2018; Liu *et al.*, 2016; Pyzik *et al.*, 2018; Sotto *et al.*, 2018; Stiborova *et al.*, 2015) recorded similar findings. Their abundance can be attributed to the fact that they are ubiquitous and are resistant to extreme environmental factors (Niestępski *et al.*, 2020). The higher dominance of bacteria can also be attributed to the complexity of the feed domestic wastewater sludge containing a broad spectrum of substances (Liu *et al.*, 2016). Despite the importance of the organic matter degraders in this system, the key players in biogas production are usually the methanogenic archaea. They often contribute to a small fraction of the total microbial communities in sewage sludge (Pyzik *et al.*, 2018) and are recorded in this study. Lagoon 1 (fresh sludge) was dominated by the *Methanosarcina*, while lagoon two (aged sludge) was dominated by the *Methanospirillum*. The predominance of syntrophic propionate oxidizers *Candidatus cloamonas* in lagoon 2 has been linked to propionate oxidation to acetate and hydrogen with energy generated through substrate-level phosphorylation on the propionyl-CoA (Lovely, 2008; Metcalf, 2016; Stems & Plugge (2009). This suggests a possible syntrophic relationship between the bacteria and the methanogenic archaea in this lagoon.

The dominant phyla identified in the fresh and aged lagoons were similar to those detected in other studies but in varying proportions (Little *et al.*, 2020; Pyzik *et al.*, 2018; Yergeau *et al.*, 2016). Pyzik *et al.* (2018) demonstrated that aged sludge was dominant with *Bacteroides*, *Clostridium*, and *Candidatus cloamonas* but a comparatively lower diversity and abundance of the same organisms in the fresh sludge. The predominance of these genera can be attributed to their ability to resist heat, desiccation, toxic chemicals, and detergents (Todar, 2006). Yergeau *et al.* (2016) found that in dewatered sludge, the dominant phyla were *Bacteroidetes*, *Proteobacteria*, and *Firmicutes*. However, a comparatively lower abundance of *Actinobacteria* (Little *et al.*, 2020) demonstrated that in biosolids stored in windrows, the abundance of *Firmicutes* decreased significantly, with *Proteobacteria* becoming the dominant phyla. Among the communities analyzed in this study, lagoon 2 (aged sludge) was the most enriched with archaea, with sample 2a having the highest abundance. Kanokratana *et al.* (2011), in metagenomics investigations of anaerobic sludge communities, recorded

bacterial phyla annotated to *Proteobacteria*, *Acidobacteria* together with *Firmicutes*, *Bacteroidetes*, *Chlamydiae/Verrucomicrobia*, and *Actinobacteria*, suggesting the critical role of these microbes in plant biomass degradation.

Most of the studies on the microbial composition of sludge communities in developing countries have focused on traditional molecular procedures such as the polymerase chain reaction (PCR) and sequencing, where 454 pyrosequencing analyses such as 16S and 18S rRNA targeting specific genes in studying microbial sludge composition (Osunmakind *et al.*, 2018). To the best of our knowledge, this is the first, if not the only, study in Kenya where Next-generation sequencing and whole-genome shotgun metagenomics technique provide a comprehensive understanding of the microbial composition of sewage sludge microbial communities.

Our findings demonstrate that the annotated metagenomics samples had significantly distinct dominant groups of microorganisms in lagoons 1 and 2. The four composite samples indicated different alpha species diversity, with composite sample 2c (779 species) of lagoon 2 having the highest alpha diversity while sample 1b (747 species) of lagoon 1 portraying the lowest diversity. The Bray-Curtis measure of beta diversity by the PCoA analysis method demonstrated similarities in the community structure between samples 1b and 1c of lagoon one and dissimilarities between samples 2a and 2c of lagoon 2 at the genera level. The findings also indicate that the aging factor of the two lagoons contributed to the overall community structure similarity. It also suggests that environmental parameters such as oxidation-reduction potential (ORP), dissolved oxygen (DO), electrical conductivity (EC), pH, and temperature significantly played a role in shaping the similarity and the dissimilarity of the genera structure observed. However, it is not easy to establish if the observed community structure affects the different environmental parameters. More studies focusing on the significant effect of the environmental factors on the community structure dynamics of lagoon 1 and lagoon 2 will be prudent for gaining a better insight.

Objective two (2) was achieved by shotgun whole-genome metagenomics. The FASTQ data produced was run in MG-RAST bioinformatics software, where the generated sequences were run against the NCBI gene bank. Taxonomic profiles were then generated and analyzed using the MG-RAST analysis platform and R vegan software. Samples from aged lagoon 2 showed a significantly higher microbial community alpha diversity than lagoon 1. The Bray-Curtis similarity index showed some similarities between samples of lagoon 1 and that of lagoon 2. This is a possible indication of a correlation relationship between the microbial structure of the two digestion lagoons and the environmental

parameters. Because of the significant difference in the general composition of the microbial consortium, we, therefore, reject the second hypothesis of this study.

5.4 The methane producing communities

The whole-genome metagenomic analysis is a useful approach for comprehensively describing complex microbial communities (Pyzik *et al.*, 2018). A variety of tools are available for metagenomic analysis to enable different insights into the environmental community function and performance. This study applied a commonly used metagenomic analytical tool (MG-RAST) to describe and compare four composite samples sequence through deep shotgun metagenomics. The MG-RAST pipeline features made it possible to get the functional structure of the representative samples' phylogenetic placement of methanogenesis-related genes.

The metagenomic analysis with the MG-RAST pipeline offered an insight into the metagenomic community structure and the abundance of genes involved in methanogenesis. However, it should be noted that this is a general approach and, therefore, challenging to determine interactions between microorganisms involved in each pathway (Pyzik *et al.*, 2018). MG-RAST provides an analysis platform where KO, SEED subsystems, and the RefSeq databases are explored to allow for a more detailed view and identify a specific function with the simultaneous assignment to a taxonomic group.

The abundance of archaea corresponded well with the proportions of the different samples' functional annotations related to methanogenesis. Even though higher hits were recorded in lagoon one compared to the aged lagoon 2 for all the genes responsible for the different methanogenesis pathways, this is probably attributed to the fact that the sludge has stabilized over time and, therefore, more microbes can now thrive. Lagoon 2 recorded a higher diversity of the profiles except in the methylotrophic pathway, where lagoon 1 recorded both higher numbers of hits and diversity of organisms (Fig. 26). This can be attributed to the presence of more algal blooms on the liquid surface of lagoon 1 because some of the one-carbon compounds used by methylotrophs, such as [methanol](#) and [TMAO](#), are produced by phytoplankton (Dinasquet *et al.*, 2018).

All the pathways recorded higher diversity with Shannon Wiener indices above 2.5 except for the hydrogenotrophic pathway, which had a lower diversity of organisms but recorded the highest hits compared to the other pathways. Similar results were recorded by Pyzik *et al.* (2018). The metagenome had a relatively high abundance of genes of the hydrogenotrophic pathway despite a low abundance of *Archaea* in the samples analyzed. The

results revealed *Methanosarcina* as the most abundant archaea in the fresh lagoon 1, while *Methanospirillum* was abundant in the aged lagoon 2. Similar trends are recorded in other studies (Diaz *et al.*, 2002, Li *et al.*, 2021). Diaz *et al.* (2002) reported the *Firmicutes* and *Nitrospira* genera as the predominant bacteria while the archaea were dominated by *Methanosaeta*, *Methanosarcina*, and the *Methanospirillum*. On the other hand, Li *et al.* (2021) recorded a shift in the composition of archaea from *Methanosaeta* to *Mycobacterium*.

The majority of the annotated *mcr* sequences were assigned taxonomically to the genera *Methanoregula* and *Methanospirillum* in both lagoons suggesting these genera play a dominant role in the last step of methane production in the sludge. There is no information linking the acidophilic *Methanoregula* with the *MCR* genes as encountered in this study. Other studies suggest *Methanospirillum* (Gunsalus *et al.*, 2016); *Methanocorpusculum*, *Methanobacterium* (Keerthana *et al.*, 2019); and *Methanosaeta* (Ellis *et al.*, 2012) as the major taxonomic groups assigned to the *mcr* genes sequences. The *Methanospirillum* identified in this study is well adapted with a large genome suggesting the presence of unrecognized biochemical/physiological properties that likely extend to the other *Methanospirillaceae* and include the ability to form the unusual sheath-like structure and to successfully interact with syntrophic bacteria (Gunsalus *et al.*, 2016).

The phylogenetic placement of hydrogenotrophic pathway organisms were annotated to *Methanobrevibacter* and *Methanosarcina* genera in lagoon one, while in lagoon 2, the *Methanoregula* and *Methanospirillum* were the dominant hydrogenotrophic genera. Pyzik *et al.* (2018) reported *Methanobrevibacter*, *Methanomassiliicoccales*, *Methanoregula*, and *Methanoculleus* as the major contributors to methane production in sewage sludge. The study proved that the *hdr* genes are found in the methanogenic archaea and acid and thiosulphate reducing bacteria such as *Halanaerobium*, sulfate-reducing *Desulfovibrio*, and the alkene degrading *Desulfatibaculum*. Other studies (Kaster *et al.*, 2011; Strittmatter *et al.*, 2009) have supported this finding where "methanogenic" genes are also present in other archaea and bacteria. Kaster *et al.* (2011) reported the sulfate-reducing *Archaeoglobus fulgidus* using many enzymes and coenzymes in anaerobic lactic acid oxidation to produce CO₂, also used by methanogenic archaea in the reduction of CO₂ to methane. *Desulfobacterium autotrophicum* contains gene clusters for the heterodisulfide reductase HdrABC (Strittmatter *et al.*, 2009).

The acetoclastic pathway is the most active and essential methanogenesis pathway, especially in sludge anaerobic digesters where acetate contributes two-thirds of the total methane production (St-Pierre *et al.*, 2013). The *Methanosarcina* and *Methanosaeta* have

been described as the genera where acetoclastic methanogenesis occurs (Fenchel *et al.*, 2012; Vincent *et al.*, 2021). The phylogenetic placement of the *cdr* genes was assigned to *Clostridium* and *Methanoregula* as the major taxonomic groups in this category in lagoon 1 and the aged lagoon 2, respectively. The abundance of *Clostridium* in lagoon 1 acetoclastic pathway consortium compared to methanogens is an exciting phenomenon suggesting the possibility that they play a role in the production of acetate. Dyksama *et al.* (2020) support the involvement of some bacteria, such as clostridia, when studying metabolic reconstruction of metagenome-assembled genomes (MAGs) from a thermophilic sewage waste biowaste digester covering the essential functions of the biogas microbial community; consistently identified the uncultured *Dethiobacteraceae* together with *Syntrophaceticus*, *Tepidanaerobacter*, and unclassified *Clostridia* as members of a potential acetate-oxidizing core community in nine full-scale digesters, whereas acetoclastic methanogens were barely detected. This may be annotated to the fact that acetoclastic methanogens and syntrophic acetate-oxidizing bacteria (SAOB) compete for acetate, a central intermediate in the mineralization of organic matter. The results presented in this study may provide new insights into a remarkable anaerobic digestion ecosystem where members of the Bacteria domain possibly realize acetate catabolism. Dyksama *et al.* (2020) further demonstrated this by metagenomics and enrichment cultivation, revealing a core community of diverse and novel uncultured acetate-oxidizing bacteria and concluding that their genomic repertoire suggests metabolic plasticity besides the potential for syntrophic acetate oxidation. Gou *et al.* (2020) found that contaminants such as antibiotics limit acetoclastic methanogens, and the resistant syntrophic acetate bacterial oxidants take over from the methanogens. A suggestion has been given that there might be a shift where syntrophic acetate oxidation replaces acetoclastic methanogenesis during thermophilic digestion of bio-waste (Campanaro *et al.*, 2020). Nevertheless, there is a need for more studies to quantify syntrophic acetate oxidation versus acetoclastic methanogenesis.

The methylotrophic pathway was dominated by *Methanosaeta* and *Methanothermobacter* genera in the lagoons 1. *Methanoregula* and *Methanospirillum* were the dominant methylotrophic methane producers in the aged lagoons. Buan (2018) reported a similar result in anaerobic digesters with *Methanomassiliicoccus*, *Methanosarcina*, *methanospirillum*, and *methanosaeta* in the list of organisms representing the methylotrophic pathway. *Nitrosococcus*, *Methylococcus*, and *Methylobacterium* were the abundant bacteria in this freshly prepared lagoon 1, while the *Thermincola*, *Mycobacterium*, and *Methylococcus* were abundant bacteria in the methylotrophic annotated consortium. Kaster *et al.* (2011)

suggest the existence of the methylotrophic bacteria that use methanogenic enzymes and coenzymes in their energy metabolism. According to Gilmore *et al.* (2017), *Methanobacterium*, *Methanosarcina*, *Methanosphaera*, and *Methanocorpusculum* are suggested to be capable of methylotrophic, acetoclastic, and hydrogenotrophic methanogenesis. In this study, *Methanoregula* seemed to be dominating all the three methanogenesis pathways. This is probably because they have an ability that trends towards energy conservation in genome composition (Kaster *et al.*, 2011).

Objective three (3) was achieved by the best hit search of the microbes responsible for the different stages of methane formation. The approach presented in this study allowed exploration in detail of complex microbial communities coming from methane-producing environments. Microbial communities in methane-producing sludge environments would be expected to contain a high abundance of genes of different steps of hydrogenotrophic, acetoclastic, and methylotrophic pathways, which optimally are encoded by a few microbes. This view was accurate for the two lagoons under investigation, especially in the freshly created lagoon 1. Nevertheless, we observed different levels of methanogenesis genes and their dispersion amongst various microorganisms. This was especially apparent for the acetoclastic pathway suggesting that the syntrophic acetate oxidation bacteria are reservoirs of metagenomic genes that contribute to the methane cycle. There was no significant difference in the diversity of acetoclastic and the hydrogenotrophic pathways. However, the methylotrophic pathways were significantly different between the lagoons. The organisms responsible for the last step release of methane gas were significantly different among the four samples, and therefore we reject hypothesis 3.

CHAPTER SIX

CONCLUSIONS AND RECOMENDATIONS

6.1 Conclusions

- i. Very high concentrations of Calcium (Ca), Sodium (Na), Potassium (K), Magnesium (Mg), Manganese (Mn), Zinc (Zn), Iron (Fe), and Copper (Cu) in the dry beds compared to the sludge tank. In the lagoons, bulk density, particle density, porosity, PH, DO, EC, ORP, and moisture were not significantly different, and therefore we accept hypothesis 1 for these parameters. We reject hypothesis 1 for Temperature, TS, VS, TC, TN, and TP since they showed significant differences between the sampling points.
- ii. Samples from aged lagoon 2 showed a significantly higher microbial community alpha diversity than lagoon 1. The Bray-Curtis similarity index showed some similarities between samples of lagoon 1 and that of lagoon 2. Because of the significant difference in the general composition of the microbial consortium, we, therefore, reject the second hypothesis of this study.
- iii. There was no significant difference in the diversity of acetoclastic and the hydrogenotrophic pathways. However, the methylotrophic pathways were significantly different between the lagoons. The organisms responsible for the last step release of methane gas were significantly different among the four samples, and therefore we reject hypothesis 3.

6.2 Recommendations

- i. Based on the findings of this study, there is a need to do more research on how to improve and stabilize the Physico-chemical parameters in the sludge treatment before agricultural use. In addition, more research should be done to investigate the suitability of the sludge as a substrate for different crops grown in the region around Nyeri County. The utilization of this sewage sludge to manufacture other products in line with tenets of the circular economy is also an option that can be explored in due course. There is also a need to improve the TS, VS, ORP, and Temperature to levels that favour biogas production in the two lagoons as far as improvising the plant for biogas production is concerned.
- ii. There is a need to quantify the methane produced by the different pathways of methanogenesis. An investigation of the effect of factors such as heavy metals and

antibiotics on microbes responsible for the different stages of methane production at the plant will also be prudent.

- iii. Proceed to pilot experiment on the efficiency of the main methanogens identified in this study to produce biogas, individually and as a consortium.

REFERENCES

- Agnew, J. M., & Leonard, J. J. (2003). The physical properties of compost. *Compost Science & Utilization*, 11(3), 238-264.
<https://www.tandfonline.com/doi/abs/10.1080/1065657X.2003.10702132>
- Ajeej, A.J., Thanikal, J. V., Narayanan, C. M., & Kumar, R. S. (2015). An overview of bio augmentation of methane by anaerobic co-digestion of municipal sludge along with microalgae and waste paper. *Renewable and Sustainable Energy Reviews*, 50, 270-276. <https://ideas.repec.org/a/eee/rensus/v50y2015icp270-276.html>
- Al-Malack, M. H., Abuzaid, N. S., & Bukhari, A. A. (2008). Physico-chemical characteristics of municipal sludge produced at three major cities of the eastern province of Saudi Arabia. *Journal of King Saud University-Engineering Sciences*, 20 (1), 15-26.
<http://masder.kfnl.gov.sa/bitstream/123456789/13859/2/U01M02V20I01A05.pdf?locale=ar>
- Alvarez, V.M, Teal, T. K., & Schmidt, T. M. (2009). Systematic artifacts in metagenomes from complex microbial communities. *The ISME Journal*, 3(11), 1314-1317.
<https://www.nature.com/articles/ismej200972>
- American Public Health Association (1998). Standard methods for the examination of water and wastewater, 21st Edition. *American Water Works Association and Water Control Federation*. Washington DC, USA.
[https://www.scirp.org/\(S\(lz5mqp453edsnp55rrgict55\)\)/reference/ReferencesPapers.aspx?ReferenceID=1909322](https://www.scirp.org/(S(lz5mqp453edsnp55rrgict55))/reference/ReferencesPapers.aspx?ReferenceID=1909322)
- Andreoli, C. V., Von Sperling, M., & Fernandes, F. (2007). *Sludge treatment and disposal*. IWA publishing, 6, 278-294.
- Angelidaki, I., Karakashev, D., Batstone, D. J., Plugge, C. M., & Stams, A. J. (2011). Biomethanation and its potential. *Methods in Enzymology*, 494, 327-351. Academic Press. <https://pubmed.ncbi.nlm.nih.gov/21402222/>
- Badza, T., Tesfamariam, E. H., & Cogger, C. G. (2020). Agricultural use suitability assessment and characterization of municipal liquid sludge: based on South Africa survey. *Science of the Total Environment*, 721, 137- 658.
<https://www.sciencedirect.com/science/article/abs/pii/S0048969720311694>

- Bano, K., Kuddus, M., R Zaheer, M., Zia, Q., F Khan, M., Gupta, A., & Aliev, G. (2017). Microbial enzymatic degradation of biodegradable plastics. *Current Pharmaceutical Biotechnology*, 18(5), 429-440. <https://pubmed.ncbi.nlm.nih.gov/28545359/>
- Barraoui, D., Blais, J. F., & Labrecque, M. (2021). Cleanup of sewage sludge spiked with Cd, Cu, and Zn: Sludge quality and distribution of metals in the “soil-plant-water” system. *Chemosphere*, 26 (7), 129-223. https://www.sciencedirect.com/science/article/pii/S0045653520334202?dgcid=rss_sd_all
- Bartee, L., Shriner, W., & Creech, C. (2017). Organizing Life on Earth. *Principles of Biology*, 21 (5), 138-164. <https://openoregon.pressbooks.pub/mhccmajorsbio/>
- Bauters, T. W., Steenhuis, T. S., Parlange, J. Y., & Carlo, D. A. (1998). Preferential flow in water repellent sands. *Soil Science Society of America Journal*, 62 (5), 1185-1190. <https://www.scirp.org/%28S%28vtj3fa45qm1ean45vffcz55%29%29/reference/referencespapers.aspx?referenceid=1174630>
- Bedaiwy, M. N. A. (2012). A simplified approach for determining the hydrometer's dynamic settling depth in particle-size analysis. *Catena*, 9 (7), 95-103. https://www.researchgate.net/publication/257169477_A_simplified_approach_for_determining_the_hydrometer's_dynamic_settling_depth_in_particle-size_analysis
- Beer, M., Stratton, H. M., Griffiths, P. C., & Seviour, R. J. (2006). Which are the polyphosphate accumulating organisms in full-scale activated sludge enhanced biological phosphate removal systems in Australia? *Journal of Applied Microbiology*, 100 (2), 233-243. <https://sfamjournals.onlinelibrary.wiley.com/doi/abs/10.1111/j.1365-2672.2005.02784.x>
- Blasco, R., Batlle P, Villano, M., Balaguer, M., Colprim, J., & Puig, S. (2017). On the edge of research and technological application: a critical review of electromethanogenesis. *International Journal of Molecular Sciences*, 18(4), 68-74. <https://www.ncbi.nlm.nih.gov/pmc/articles/PMC5412455/>
- Bora, R.R., Richardson R.E., & You, F. (2020) Resource recovery and waste-to-energy from wastewater sludge via thermochemical conversion technologies in support of circular economy: a comprehensive review, Bora et al. *BMC Chemical Engineering*, 47, 777-780. <https://doi.org/10.1186/s42480-020-00031-3>

- Bożym, M., & Siemiątkowski, G. (2018). Characterization of composted sewage sludge during the maturation process: a pilot scale study. *Environmental Science and Pollution Research*, 25(34), 34332-34342.
- Brdanovic, D. (1998). *Modeling Biological Phosphorus Removal in Activated Sludge Systems* (Doctoral dissertation, UNESCO-IHE, Institute for Water Education). <https://ocw.un-ihe.org/mod/resource/view.php?id=848>
- Bretz, K. A., & Whalen, S. C. (2014). Methane cycling dynamics in sediments of Alaskan Arctic Foothill lakes. *Inland Waters*, 4(1), 65-78.
<https://www.tandfonline.com/doi/pdf/10.5268/IW-4.1.637>
- Buan, N. R. (2018). Methanogens: pushing the boundaries of biology. *Emerging Topics in Life Sciences*, 2(4), 629-646.
<https://portlandpress.com/emergtoplifesci/article/2/4/629/77362/Methanogens-pushing-the-boundaries-of-biology>
- Cáceres, R., Malińska, K., & Marfà, O. (2018). Nitrification within composting: a review. *Waste Management*, 72, 119-137. <https://pubmed.ncbi.nlm.nih.gov/29153903/>
- Camargo, F. P., Tonello, P. S., dos Santos, A. C. A., and Duarte, I. C. S. (2016). Removal of toxic metals from sewage sludge through chemical, physical, and biological treatments: a review. *Water, Air, & Soil Pollution*, 227(12), 1-11.
<https://repositorio.unesp.br/bitstream/handle/11449/169109/2-s2.0-84994509825.pdf?sequence=1>
- Campanaro, S., Treu, L., Kougias, P. G., De Francisci, D., Valle, G., & Angelidaki, I. (2016). Metagenomic analysis and functional characterization of the biogas microbiome using high throughput shotgun sequencing and a novel binning strategy. *Biotechnology for Biofuels*, 9(1), 1-17.
<https://biotechnologyforbiofuels.biomedcentral.com/articles/10.1186/s13068-016-0441-1>
- Campanaro, S., Treu, L., Rodriguez-R, L. M., Kovalovszki, A., Ziels, R. M., Maus, I., & Angelidaki, I. (2020). New insights from the biogas microbiome by comprehensive genome-resolved metagenomics of nearly 1600 species originating from multiple anaerobic digesters. *Biotechnology For Biofuels*, 13(1), 1-18.
<https://biotechnologyforbiofuels.biomedcentral.com/articles/10.1186/s13068-016-0441-1>
- Chan, O. C., Claus, P., Casper, P., Ulrich, A., Lueders, T., & Conrad, R. (2005). Vertical distribution of structure and function of the methanogenic archaeal community in

- Lake Dagow sediment. *Environmental Microbiology*, 7(8), 1139-1149.
<https://biotechnologyforbiofuels.biomedcentral.com/articles/10.1186/s13068-016-0441-1>
- Chen, H., Zhu, T., Li, B., Fang, C., and Nie, M. (2020). The thermal response of soil microbial methanogenesis decreases in magnitude with changing temperature. *Nature Communications*, 11(1), 1-7. <https://www.nature.com/articles/s41467-020-19549-4>
- Chibani, S., Sidoti, J., Bruttin, A., Kutter, E., Sarker, S., & Brüssow, H. (2004). In vitro and in vivo bacteriolytic activities of *Escherichia coli* phages: implications for phage therapy. *Antimicrobial Agents and Chemotherapy*, 48(7), 2558-2569.
<https://www.ncbi.nlm.nih.gov/pmc/articles/PMC434175/>
- Chimdi, A., Gebrekidan, H., Kibret, K., & Tadesse, A. (2012). Status of selected physicochemical properties of soils under different land use systems of Western Oromia, Ethiopia. *Journal of Biodiversity and Environmental Sciences*, 2(3), 57-71.
<https://www.iiste.org/Journals/index.php/JBAH/article/download/57007/58870>
- Chistoserdova, L. (2011). Modularity of methylotrophy, revisited. *Environmental microbiology*, 13(10), 2603-2622. <https://pubmed.ncbi.nlm.nih.gov/21443740/>
- Cieślak, B. M., Namieśnik, J., & Konieczka, P. (2015). Review of sewage sludge management: standards, regulations and analytical methods. *Journal of Cleaner Production*, 90, 1-15.
<https://www.sciencedirect.com/science/article/pii/S0959652614012116>
- Cohen, G. N. (2014). Methanogens & methylotrophs. In *Microbial Biochemistry* (pp. 153-177). Dordrecht: Springer.
<https://link.springer.com/book/10.1007/978-94-017-8908-0>
- Cramer, B., & Franke, D. (2005). Indications for an active petroleum system in the Laptev Sea, NE Siberia. *Journal of Petroleum Geology*, 28(4), 369-384.
<https://onlinelibrary.wiley.com/doi/abs/10.1111/j.1747-5457.2005.tb00088.x>
- Deppenmeier, U., Müller, V., & Gottschalk, G. (1996). Pathways of energy conservation in methanogenic archaea. *Archives of Microbiology*, 165(3), 149-163.
<https://link.springer.com/article/10.1007/BF01692856>
- Dhoble, A. S., Bekal, S., Dolatowski, W., Yanz, C., Lambert, K. N., & Bhalerao, K. D. (2016). A novel high-throughput multi-parameter flow cytometry based method for monitoring and rapid characterization of microbiome dynamics in anaerobic systems. *Bioresource Technology*, 220, 566-571. <https://pubmed.ncbi.nlm.nih.gov/27614579/>

- Díaz, E. E., Stams, A. J., Amils, R., & Sanz, J. L. (2006). Phenotypic properties and microbial diversity of methanogenic granules from a full-scale upflow anaerobic sludge bed reactor treating brewery wastewater. *Applied and Environmental Microbiology*, 72(7), 4942-4949. <https://www.ncbi.nlm.nih.gov/pmc/articles/PMC1489364/>
- Dinasquet, J., Tirola, M., & Azam, F. (2018). Enrichment of bacterioplankton able to utilize one-carbon and methylated compounds in the coastal Pacific Ocean. *Frontiers in Marine Science*, 5 (7), 307-320. <https://www.frontiersin.org/articles/10.3389/fmars.2018.00307/full>
- Dobbernack, E., Schoberth, S. M., & Sahn, H. (1988). Relationship of intracellular coenzyme F420 content to growth and metabolic activity of *Methanobacterium bryantii* and *Methanosarcina barkeri*. *Applied and Environmental Microbiology*, 54(2), 454-459. <https://www.ncbi.nlm.nih.gov/pmc/articles/PMC202472/>
- Douglas, B., Kimwaga, R., & Mayo, A. (2021). Variability of faecal sludge characteristics and its implication for dewaterability across different onsite sanitation containments in unplanned settlements in Dar es Salaam, Tanzania. *Water Practice and Technology*, 34 (7), 127-137.. <https://pubmed.ncbi.nlm.nih.gov/34147994/>
- Dubey, M., Mohapatra, S., Tyagi, V. K., Suthar, S., & Kazmi, A. A. (2021). Occurrence, fate, and persistence of emerging micropollutants in sewage sludge treatment. *Environmental Pollution*, 273, 116-515. <https://pubmed.ncbi.nlm.nih.gov/33493756/>
- Dyksma, S., Jansen, L., & Gallert, C. (2020). Syntrophic acetate oxidation replaces acetoclastic methanogenesis during thermophilic digestion of biowaste. *Microbiome*, 8(1), 1-14. <https://microbiomejournal.biomedcentral.com/articles/10.1186/s40168-020-00862-5>
- Ellis, J. T., Tramp, C., Sims, R. C., & Miller, C. D. (2012). Characterization of a methanogenic community within an algal fed anaerobic digester. *International Scholarly Research Notices*, 12, 133-145. <https://www.hindawi.com/journals/isrn/2012/753892/>
- Environmental, Y. S. I. (2008). ORP Management in wastewater as an indicator of process efficiency. *YSI, Yellow Springs, OH. Management-in-Wastewater-as-an-Indicator-of-Process-Efficiency*. pdf (accessed on 15.08. 21). <https://www.ysi.com/file%20library/documents/application%20notes/a567-orp-management-in-wastewater-as-an-indicator-of-process-efficiency.pdf>

- Enzmann, F., Mayer, F., Rother, M., & Holtmann, D. (2018). Methanogens: biochemical background and biotechnological applications. *Amb Express*, 8(1), 1-22. <https://amb-express.springeropen.com/articles/10.1186/s13568-017-0531-x>
- Fayer, R., & Xiao, L. (Eds.). (2007). *Cryptosporidium and Cryptosporidiosis*. CRC press. <https://www.routledge.com/Cryptosporidium-and-Cryptosporidiosis/Fayer-Xiao/p/book/9781420052268>
- Fenchel, T., & Finlay, B. J. (2010). Free-living protozoa with endosymbiotic methanogens. (*Endo*) *Symbiotic Methanogenic Archaea*, 1-11. https://www.researchgate.net/publication/225995759_Free_Living_Protozoa_with_Endosymbiotic_Methanogens
- Fenchel, T., King, G. M., & Blackburn, T. H. (2012). *Bacterial biogeochemistry: the ecophysiology of mineral cycling*. *Bacterial Biogeochemistry*, 121-142. <https://www.elsevier.com/books/bacterial-biogeochemistry/fenchel/978-0-12-415836-8>
- Ferry, J. G. (1992). Biochemistry of methanogenesis. *Critical Reviews in Biochemistry and Molecular Biology*, 27(6), 473-503. <https://www.tandfonline.com/doi/abs/10.3109/10409239209082570>
- Finazzo, C., Harmer, J., Bauer, C., Jaun, B., Duin, E. C., Mahlert, F., and Schweiger, A. (2003). Coenzyme B induced coordination of coenzyme M via its thiol group to Ni (I) of F430 in active methyl-coenzyme M reductase. *Journal of the American Chemical Society*, 125(17), 4988-4989. <https://pubmed.ncbi.nlm.nih.gov/12708843/>
- Foissner, W., & Berger, H. (1996). A user-friendly guide to the ciliates (Protozoa, Ciliophora) commonly used by hydrobiologists as bioindicators in rivers, lakes, and waste waters, with notes on their ecology. *Freshwater Biology*, 35(2), 375-482. <https://onlinelibrary.wiley.com/doi/abs/10.1111/j.1365-2427.1996.tb01775.x>
- Galagan, J. E., Nusbaum, C., Roy, A., Endrizzi, M. G., Macdonald, P., FitzHugh, W., & Birren, B. (2002). The genome of *M. acetivorans* reveals extensive metabolic and physiological diversity. *Genome Research*, 12(4), 532-542. <https://pubmed.ncbi.nlm.nih.gov/11932238/>
- Garcia J., Patel, B. K., & Ollivier B. (2000). Taxonomic, phylogenetic, and ecological diversity of methanogenic Archaea, *Anaerobe*. 6:205–226. <https://pubmed.ncbi.nlm.nih.gov/16887666/>
- Ge, H., Batstone, D. J., Mouiche, M., Hu, S., & Keller, J. (2017). Nutrient removal and energy recovery from high-rate activated sludge processes—Impact of sludge age.

<https://pubmed.ncbi.nlm.nih.gov/28863992/>

Ge, X., Yang, L., Sheets, J. P., Yu, Z., & Li, Y. (2014). Biological conversion of methane to liquid fuels: status and opportunities. *Biotechnology Advances*, 32(8), 1460-1475.

<https://www.sciencedirect.com/science/article/pii/S0734975014001499>

Gilbride, K. A., Lee, D. Y., & Beaudette, L. A. (2005). Molecular techniques in wastewater: understanding microbial communities, detecting pathogens, and real-time process control. *Journal of Microbiological Methods*, 66(1), 1-20.

<https://pubmed.ncbi.nlm.nih.gov/16635533/>

Gilmore, S. P., Henske, J. K., Sexton, J. A., Solomon, K. V., Seppälä, S., Yoo, J. I., & O'Malley, M. A. (2017). Genomic analysis of methanogenic archaea reveals a shift towards energy conservation. *BMC Genomics*, 18(1), 1-14.

Ginige, M. P., Hugenholtz, P., Daims, H., Wagner, M., Keller, J., & Blackall, L. L. (2004). Use of stable-isotope probing, full-cycle rRNA analysis, and fluorescence in situ hybridization-microautoradiography to study a methanol-fed denitrifying microbial community. *Applied and Environmental Microbiology*, 70(1), 588-596.

<https://www.ncbi.nlm.nih.gov/pmc/articles/PMC321253/>

Giwa, A. S., Ali, N., Athar, M. A., & Wang, K. (2019). Dissecting microbial community structure in sewage treatment plant for pathogens' detection using metagenomic sequencing technology. *Archives of Microbiology*, 19 (8).265-276.

<https://pubmed.ncbi.nlm.nih.gov/31848653/>

Gold, M., Ddiba, D. I. W., Seck, A., Sekigongo, P., Diene, A., Diaw, S., & Strande, L. (2017). Faecal sludge as a solid industrial fuel: a pilot-scale study. *Journal of Water, Sanitation and Hygiene for Development*, 7(2), 243-251.

<https://iwaponline.com/washdev/article/7/2/243/30234/Faecal-sludge-as-a-solid-industrial-fuel-a-pilot>

Gou, M., Wang, H., Li, J., Sun, Z., Nie, Y., Nobu, M. K., & Tang, Y. (2020). Different inhibitory mechanisms of chlortetracycline and enrofloxacin on mesophilic anaerobic degradation of propionate. *Environmental Science and Pollution Research*, 27(2), 1406-1416. <https://pubmed.ncbi.nlm.nih.gov/31745805/>

Gray, N. D., Miskin, I. P., Kornilova, O., Curtis, T. P., & Head, I. M. (2002). Occurrence and activity of Archaea in aerated activated sludge wastewater treatment plants.

Environmental Microbiology, 4(3), 158-168.

<https://pubmed.ncbi.nlm.nih.gov/12000316/>

- Groenendyk, D. G., Ferré, T. P., Thorp, K. R., & Rice, A. K. (2015). Hydrologic-process-based soil texture classifications for improved visualization of landscape function. *PloS One*, *10*(6), 131-199.
<https://journals.plos.org/plosone/article?id=10.1371/journal.pone.0131299>
- Grotenhuis, J. T., Smit, M., Plugge, C. M., Xu, Y. S., Van Lammeren, A. A., Stams, A. J., & Zehnder, A. J. (1991). Bacteriological composition and structure of granular sludge adapted to different substrates. *Applied and Environmental Microbiology*, *57*(7), 942-949. <https://www.ncbi.nlm.nih.gov/pmc/articles/PMC183503/>
- Gudda, F. O., Moturi, W. N., Omondi, S. O., & Muchiri, E. W. (2017). Analysis of physiochemical characteristics influencing disposal of pit latrine sludge in Nakuru Municipality, Kenya. *African Journal of Environmental Science and Technology*, *11* (3), 139-145. <https://academicjournals.org/journal/AJEST/article-full-text-pdf/787C3FA62909>
- Gunsalus, R. P., Cook, L. E., Crable, B., Rohlin, L., McDonald, E., Mouttaki, H., & McInerney, M. J. (2016). Complete genome sequence of *Methanospirillum hungatei* type strain JF1. *Standards In Genomic Sciences*, *11*(1), 1-10.
<https://www.ncbi.nlm.nih.gov/pmc/articles/PMC4704411/>
- Harold, J. (2002). Antibiotic Sensitivity Testing. *Microbial Applications: Lab Manual in General Microbiology*. 8th Ed. McGraw Hill, 118 (27), 331-347.
<https://www.amazon.com/Microbiological-Applications-Laboratory-Microbiology-Complete/dp/0072318880>
- Heyer, R., Kohrs, F., Reichl, U., & Benndorf, D. (2015). Metaproteomics of complex microbial communities in biogas plants. *Microbial Biotechnology*, *8*(5), 749-763.
<https://www.ncbi.nlm.nih.gov/pmc/articles/PMC4554464/>
- Hirakata, Y., Hatamoto, M., Oshiki, M., Watari, T., Araki, N., and Yamaguchi, T. (2020). Food selectivity of anaerobic protists and direct evidence for methane production using carbon from prey bacteria by endosymbiotic methanogen. *The ISME Journal*, *14*(7), 1873-1885. <https://www.ncbi.nlm.nih.gov/pmc/articles/PMC7305177/>
- Hirakata, Y., Oshiki, M., Kuroda, K., Hatamoto, M., Kubota, K., Yamaguchi, T., & Araki, N. (2015). Identification and detection of prokaryotic symbionts in the ciliate *Metopus* from anaerobic granular sludge. *Microbes and Environments*, *30*(4), 335-338.
<https://www.ncbi.nlm.nih.gov/pmc/articles/PMC4676557/>
- Hirakata, Y., Oshiki, M., Kuroda, K., Hatamoto, M., Kubota, K., Yamaguchi, T., & Araki, N. (2016). Effects of predation by protists on prokaryotic community function, structure,

- and diversity in anaerobic granular sludge. *Microbes and Environments*, 1,60-67.
<https://www.ncbi.nlm.nih.gov/pmc/articles/PMC5017804/>
- Hoehler, T., Losey, N. A., Gunsalus, R. P., & McInerney, M. J. (2018). *Environmental Constraints that Limit Methanogenesis*. Univ. of Oklahoma, Norman, OK (United States). <https://www.osti.gov/biblio/1604967-environmental-constraints-limit-methanogenesis-reference-work-chapter>
<https://bmcgenomics.biomedcentral.com/articles/10.1186/s12864-017-4036-4>
<https://link.springer.com/article/10.1007/s11356-018-3335-x>
<https://www.iwapublishing.com/sites/default/files/ebooks/9781780402130.pdf>
- Huse, S. M., Huber, J. A., Morrison, H. G., Sogin, M. L., & Welch, D. M. (2007). Accuracy and quality of massively parallel DNA pyrosequencing. *Genome Biology*, 8(7), 1-9.
<https://genomebiology.biomedcentral.com/articles/10.1186/gb-2007-8-7-r143>
- Jenkins, T. C., Wallace, R. J., Moate, P. J., and Mosley, E. E. (2004). Board-invited review: Recent advances in biohydrogenation of unsaturated fatty acids within the rumen microbial ecosystem. *Journal of Animal Science*, 86(2), 397-412.
<https://pubmed.ncbi.nlm.nih.gov/18042812/>
- Johnke, J., Cohen, Y., de Leeuw, M., Kushmaro, A., Jurkevitch, E., & Chatzinotas, A. (2014). Multiple micro-predators controlling bacterial communities in the environment. *Current Opinion in Biotechnology*, 27, 185-190.
<https://www.sciencedirect.com/science/article/abs/pii/S0958166914000342>
- Kambura, A. K., Mwirichia, R. K., Kasili, R. W., Karanja, E. N., Makonde, H. M., & Boga, H. I. (2016). Bacteria and Archaea diversity within the hot springs of Lake Magadi and Little Magadi in Kenya. *BMC Microbiology*, 16(1), 136-139.
<https://bmcmicrobiol.biomedcentral.com/articles/10.1186/s12866-016-0748-x>
- Kanokratana, P., Uengwetwanit, T., Rattanachomsri, U., Bunternngsook, B., Nimchua, T., Tangphatsornruang, S., & Eurwilaichitr, L. (2011). Insights into the phylogeny and metabolic potential of a primary tropical peat swamp forest microbial community by metagenomic analysis. *Microbial Ecology*, 61(3), 518-528.
<https://pubmed.ncbi.nlm.nih.gov/21057783/>
- Kariunga, S., Kitaka, N., & Muia, W. (2018, July). Performance evaluation of Kangemi Sewage Plant in nutrients and organic matter removal, Nyeri Kenya. In *Transformation Towards Sustain-able and Resilient WASH Services: Proceedings of the 41st WEDC International Conference, Nakuru, Kenya*, (pp. 9-13). cc WEDC, Loughborough University.

https://repository.lboro.ac.uk/articles/conference_contribution/Performance_evaluation_of_Kangemi_Sewage_Plant_in_nutrients_and_organic_matter_removal_Nyeri_kenya/9592553/1

Kaster, A. K. (2011). More than 200 genes required for methane formation from H₂ and CO₂ and energy conservation are present in *Methanothermobacter marburgensis* and *Methanothermobacter thermoautotrophicus*. *Archaea*, 3 (1) 50-62.

<https://www.ncbi.nlm.nih.gov/pmc/articles/PMC3087415/>

Kasza, G., Bódi, B., Sárközi, E., Mázsa, Á., & Kardos, L. (2015). Vermicomposting of Sewage Sludge—Experiences of A Laboratory Study. *International Journal of Bioscience, Biochemistry and Bioinformatics*, 5(1), 127-137.

<http://www.ijbbb.org/vol5/389-E2003.pdf>

Katz, B. J. (2011). Microbial processes and natural gas accumulations. *The Open Geology Journal*, 5(1) 134-142.

https://www.researchgate.net/publication/258540632_Microbial_Processes_and_Natural_Gas_Accumulations

Keerthana, K. P., Krishnan, S. R., Sengali, S. R., Srinivasan, R., Prabhakaran, N., Balaji, G., & Latha, K. (2019). Microbiome digital signature of MCR genes—an in silico approach to study the diversity of methanogenic population in laboratory-developed and pilot-scale anaerobic digesters. *Access Microbiology*, 1(5) 142-150.

<https://pubmed.ncbi.nlm.nih.gov/32974529/>

Keffala, C., Harerimana, C., & Vasel, J. L. (2013). A review of the sustainable value and disposal techniques, wastewater stabilisation ponds sludge characteristics and accumulation. *Environmental Monitoring and Assessment*, 185(1), 45-58.

<https://link.springer.com/article/10.1007/s10661-012-2532-1>

Kelly Kambura, A.K., Mwirichia, R.K., Kasili, R.W., Karanja E.N., Makonde, H.M., & Boga, H.I (2016). Diversity of fungi in sediments and water sampled from the hot springs of Lake Magadi and Little Magadi in Kenya, *African Journal of Microbiology Research* 10(10), 330-338. <https://academicjournals.org/journal/AJMR/how-to-cite-article/128717757661>

<https://academicjournals.org/journal/AJMR/how-to-cite-article/128717757661>

Kelly, B. C. (2005). Mechanical properties of dewatered sewage sludge. *Waste Management*, 25 (1), 47-52.

https://www.researchgate.net/publication/8051301_Mechanical_properties_of_dewatered_sewage_sludge

- Khadra, A., Pinelli, E., Ezzariai, A., Mohamed, O., Merlina, G., Lyamlouli, K. & Hafidi, M. (2019). Assessment of the genotoxicity of antibiotics and chromium in primary sludge and compost using *Vicia faba* micronucleus test. *Ecotoxicology and Environmental Safety*, 185 (10), 93-96. <https://ur.booksc.me/book/77035543/b97c76>
- Kietäväinen, R., & Purkamo, L. (2015). The origin, source, and cycling of methane in deep crystalline rock biosphere. *Frontiers In Microbiology*, 6, 725-739. <https://www.frontiersin.org/articles/10.3389/fmicb.2015.00725/full>
- Klappenbach, J. A., Saxman, P. R., Cole, J. R., & Schmidt, T. M. (2001). The ribosomal RNA operon copy number database. *Nucleic Acids Research*, 29(1), 181-184. <https://www.ncbi.nlm.nih.gov/pmc/articles/PMC29826/>
- Kominko, H., Gorazda, K., Wzorek, Z., & Wojtas, K. (2018). Sustainable management of sewage sludge for the production of organo-mineral fertilizers. *Waste and Biomass Valorization*, 9(10), 1817-1826. <https://link.springer.com/article/10.1007/s12649-017-9942-9>
- Kong, Y., Xia, Y., Seviour, R., Forster, R., & McAllister, T. A. (2013). Biodiversity and composition of methanogenic populations in the rumen of cows fed alfalfa hay or triticale straw. *FEMS Microbiology Ecology*, 84(2), 302–315. <https://academic.oup.com/femsec/article-pdf/84/2/302/19534605/84-2-302.pdf>
- Kröber, M., Bekel, T., Diaz, N. N., Goesmann, A., Jaenicke, S., Krause, L., & Schlüter, A. (2009). Phylogenetic characterization of a biogas plant microbial community integrating clone library 16S-rDNA sequences and metagenome sequence data obtained by 454-pyrosequencing. *Journal of Biotechnology*, 142(1), 38-49. <https://pubmed.ncbi.nlm.nih.gov/19480946/>
- Kuffour, R. A. (2010). Improving faecal sludge dewatering efficiency of unplanted drying bed. *Kumasi, Ghana: Kwame Nkurumah Univ. of Science and Technology*, 81 (7), 182-197. https://ocw.un-ihc.org/pluginfile.php/4126/mod_resource/content/1/Kuffour_Improvement%20Unplanted%20Drying%20Beds.pdf
- Kumar, S., Mitnik, C., Valente, G., & Floyd-Smith, G. (2000). Expansion and molecular evolution of the interferon-induced 2'–5' oligoadenylate synthetase gene family. *Molecular Biology and Evolution*, 17(5), 738-750. <https://academic.oup.com/mbe/article/17/5/738/981019>

- Kurth, J. M., Op den Camp, H. J., & Welte, C. U. (2020). Several ways one goal—methanogenesis from unconventional substrates. *Applied Microbiology and Biotechnology*, 104(16), 6839-6854. <https://pubmed.ncbi.nlm.nih.gov/32542472/>
- Langmead, B., Trapnell, C., Pop, M., & Salzberg, S. L. (2009). Ultrafast and memory-efficient alignment of short DNA sequences to the human genome. *Genome Biology*, 10(3), 1-10. <https://genomebiology.biomedcentral.com/articles/10.1186/gb-2009-10-3-r25>
- Laura, F., Tamara, A., Müller, A., Hiroshan, H., Christina, D., & Serena, C. (2020). Selecting sustainable sewage sludge reuse options through a systematic assessment framework: Methodology and case study in Latin America. *Journal of Cleaner Production*, 242, 118-129. <http://www.diva-portal.org/smash/record.jsf?pid=diva2:1355903>
- Li, F.T., Wang, H.T., & Mafuta, C., (2011). Current status and technology demands for water resources and water environment in Africa. *Research on Water Resources of African Typical Areas* (Ed.: L.F. Ting), Science Press, Beijing 2011. <https://onlinelibrary.wiley.com/doi/10.1002/clen.201300208>
- Li, J. X., Wang, L. A., Wang, L., Zhan, X. Y., & Huang, C. (2021). Exploring the biogas production and microbial community from co-digestion of sewage sludge with municipal solid waste incineration fresh leachate. *International Journal of Environmental Science and Technology*, 18(4), 901-912. <https://pubag.nal.usda.gov/catalog/7312113>
- Lim, F., Fang, H. H., & Zhang, T. (2015). Application of metagenomics in environmental anaerobic technology. *Anaerobic Biotechnology: Environmental Protection and Resource Recovery*, 108, 68-74. https://www.worldscientific.com/doi/abs/10.1142/9781783267910_0005
- Lim, J. W., Ge, T., & Tong, Y. W. (2018). Monitoring of microbial communities in anaerobic digestion sludge for biogas optimisation. *Waste Management*, 71, 334-341. <https://scholarbank.nus.edu.sg/handle/10635/155048?mode=full>
- Little, K. R., Gan, H. M., Surapaneni, A., Schmidt, J., & Patti, A. F. (2020). Characterisation of bacterial diversity in fresh and aged sewage sludge biosolids using next generation sequencing. *Detritus*, 10, 82-91. <https://research.monash.edu/en/publications/characterisation-of-bacterial-diversity-in-fresh-and-aged-sewage->

- Liu, Y., & Tay, J. H. (2002). The essential role of hydrodynamic shear force in the formation of biofilm and granular sludge. *Water Research*, 36 (7), 1653-1665.
<https://pubmed.ncbi.nlm.nih.gov/12044065/>
- Lovley, D. R. (2008). The microbe electric: conversion of organic matter to electricity. *Current opinion in Biotechnology*, 19(6), 564-571.
<https://pubmed.ncbi.nlm.nih.gov/19000760/>
- Lu, S., Park, M., Ro, H. S., Lee, D. S., Park, W., & Jeon, C. O. (2006). Analysis of microbial communities using culture-dependent and culture-independent approaches in an anaerobic/aerobic SBR reactor. *The Journal of Microbiology*, 44(2), 155-161.
https://www.researchgate.net/publication/7053635_Analysis_of_microbial_communities_using_culture-dependent_and_culture-independent_approaches_in_an_anaerobicaerobic_SBR_reactor
- Luo, Y., Guo, W., Ngo, H. H., Nghiem, L. D., Hai, F. I., Zhang, J., & Wang, X. C. (2014). A review on the occurrence of micropollutants in the aquatic environment and their fate and removal during wastewater treatment. *Science of the Total Environment*, 473, 619-641. <https://pubmed.ncbi.nlm.nih.gov/24394371/>
- Luostarinen, S., Luste, S., & Sillanpää, M. (2009). Increased biogas production at wastewater treatment plants through co-digestion of sewage sludge with grease trap sludge from a meat processing plant. *Bioresource Technology*, 100(1), 79-85.
<https://pubmed.ncbi.nlm.nih.gov/18707877/>
- Makinia, J. (2010). Mathematical Modelling & Computer Simulation of Activated Sludge Systems. *Water Intelligence Online*, 9 (33), 334-347.
<https://iwaponline.com/ebooks/book/10.2166/9781780401683/Mathematical-Modelling-and-Computer-Simulation-of>
- Manh, L. D. (2008). Bioremediation of vegetable oil and grease from polluted wastewater in dairy factory. *Journal of Nature Science and Sustainable Technology*, 24, 56-62.
<https://www.semanticscholar.org/paper/Bioremediation-of-vegetable-oil-and-grease-from-in-Manh/f12c55e60664e6e828378d21aacbc95f6b0e87f2>
- Mannoubi, I. (2021). Tunisian *Opuntia stricta* Seed Oil: Extraction, Characterization, and Prediction of Fatty Acid Methyl Ester Properties as Biodiesel Fuel. *Chemistry of Natural Compounds*, 57(4), 614-619. <https://pubag.nal.usda.gov/catalog/7459355>
- Manu, K. J., Mohana, V. S., & Ganeshiah, K. N. (2011). Effluent generation by the dairy units: characterization and amelioration for irrigation. *International Journal of*

- Research in Chemistry and Environment* 1(2), 173-182.
<https://www.cabdirect.org/cabdirect/abstract/20123317776>
- Mara, D. (2004) Domestic Wastewater Treatment in Developing Countries. *Earth Scan*, London, Sterling Va.
[https://www.scirp.org/\(S\(i43dyn45teexjx455qlt3d2q\)\)/reference/ReferencesPapers.aspx?ReferenceID=2006666](https://www.scirp.org/(S(i43dyn45teexjx455qlt3d2q))/reference/ReferencesPapers.aspx?ReferenceID=2006666)
- Mathimani, T., & Mallick, N. (2018). A comprehensive review on harvesting of microalgae for biodiesel—key challenges and future directions. *Renewable and Sustainable Energy Reviews*, 91, 1103-1120.
<https://ideas.repec.org/a/eee/rensus/v91y2018icp1103-1120.html>
- Meerburg, F. A., Vlaeminck, S. E., Roume, H., Seuntjens, D., Pieper, D. H., Jauregui, R., & Boon, N. (2016). High-rate activated sludge communities have a distinctly different structure compared to low-rate sludge communities, and are less sensitive towards environmental and operational variables. *Water Research*, 100, 137-145.
<https://europepmc.org/article/med/27183209>
- Metcalf, W. W. (2016). Classic spotlight: electron bifurcation, a unifying concept for energy conservation in anaerobes. *Journal of Bacteriology*, 198(9), 1358-1364.
<https://pubmed.ncbi.nlm.nih.gov/27080054/>
- Meyer, F., Paarmann, D., D'Souza, M., Olson, R., Glass, E. M., Kubal, M., & Edwards, R. A. (2008). The metagenomics RAST server—a public resource for the automatic phylogenetic and functional analysis of metagenomes. *BMC Bioinformatics*, 9(1), 1-8.
<https://bmcbioinformatics.biomedcentral.com/articles/10.1186/1471-2105-9-386>
- Mitchell, A. L., Scheremetjew, M., Denise, H., Potter, S., Tarkowska, A., Qureshi, M., & Finn, R. D. (2018). EBI Metagenomics in 2017: enriching the analysis of microbial communities, from sequence reads to assemblies. *Nucleic Acids Research*, 46(D1), D726-D735. <https://pubmed.ncbi.nlm.nih.gov/29069476/>
- Morgan, F., Nielsen, J. L., & Nielsen, P. H. (2008). Substrate-dependent denitrification of abundant probe-defined denitrifying bacteria in activated sludge. *FEMS Microbiology Ecology*, 66(2), 447-461. <https://academic.oup.com/femsec/article/66/2/447/573469>
- Mtshali, J.S., Tiruneh, A.T., Fadiran, A. O., (2014). Characterization of Sewage Sludge Generated from Wastewater Treatment Plants in Swaziland in Relation to Agricultural Uses, *Resources and Environment*, 4(4), 190-199.
<http://article.sapub.org/10.5923.j.re.20140404.02.html>

- Muia, A.W., Kimisto, A., & Donde O.O. (2021) *Sludge Management Technologies for Sustainable Development: An Overview*. A paper presented at Machakos University, 3rd Annual International Conference on 22nd to 25th June 2021 in Machakos, Kenya. <https://www.mksu.ac.ke/others/3rd-annual-international-conference/>
- Müller, J. (2000). Disintegration as a key-step in sewage sludge treatment. *Water Science and Technology*, 41(8), 123-130. <https://iwaponline.com/wst/article/41/8/123/8801/Disintegration-as-a-key-step-in-sewage-sludge>
- Murunga, S. I., Mbugu, D. O., Gitau, A. N., Mutwiwa, U. N., & Wekesa, I. N. (2016). Isolation and characterization of methanogenic bacteria from brewery wastewater in Kenya. *African Journal of Biotechnology*, 15(47), 2687-2697. <https://www.ajol.info/index.php/ajb/article/view/149579>
- Nahhal, I. Y., Najjar, H. M., & Nahhal, Y. (2014). Physicochemical properties of sewage sludge from Gaza. *International Journal of Geosciences*, 5 (06), 612-618. https://file.scirp.org/Html/3-2800750_45708.htm
- Nakasaki, K., Hirai, H., Mimoto, H., Quyen, T. N. M., Koyama, M., & Takeda, K. (2019). Succession of microbial community during vigorous organic matter degradation in the primary fermentation stage of food waste composting. *Science of The Total Environment*, 67(1), 1237-1244. <https://agris.fao.org/agris-search/search.do?recordID=US201900220518>
- Neto, M. M., Chaves, S., & Nicolau, A. (2010). Interactions between eukaryotic and prokaryotic microorganisms in activated sludge: a molecular approach to improve wastewater treatment. *Applied and Environmental Microbiology*, 87(3), 274-288. https://repositorium.sdum.uminho.pt/bitstream/1822/33121/1/document_19775_1.pdf
- Nettmann, E., Bergmann, I., Pramschüfer, S., Mundt, K., Plogsties, V., Herrmann, C., & Klocke, M. (2010). Polyphasic analyses of methanogenic archaeal communities in agricultural biogas plants. *Applied and Environmental Microbiology*, 76(8), 2540-2548. <https://www.ncbi.nlm.nih.gov/pmc/articles/PMC3019726/>
- Nguyen, L. N., Commault, A. S., Johir, M. A. H., Bustamante, H., Aurisch, R., Lowrie, R., & Nghiem, L. D. (2019). Application of a novel molecular technique to characterise the effect of settling on microbial community composition of activated sludge. *Journal of Environmental Management*, 251, 109-594. <https://pubmed.ncbi.nlm.nih.gov/31557668/>

- Nielsen, B., Seadi, T., & Oleskowicz, P. (2009). The future of anaerobic digestion and biogas utilization. *Bioresource Technology*, 100(22), 5478-5484.
<https://www.sciencedirect.com/science/article/abs/pii/S0960852408011012>
- Niestępski, S., Harnisz, M., Ciesielski, S., Korzeniewska, E., & Osińska, A. (2020). Environmental fate of Bacteroidetes, with particular emphasis on *Bacteroides fragilis* group bacteria and their specific antibiotic resistance genes, in activated sludge wastewater treatment plants. *Journal of Hazardous Materials*, 394, 122-144.
<https://www.sciencedirect.com/science/article/pii/S0304389420305331>
- Nikiema, J., Cofie, O., Impraim, R., & Adamtey, N. (2013). Processing of fecal sludge to fertilizer pellets using a low-cost technology in Ghana. *Environment and Pollution*, 2(4), 70-87.
https://www.researchgate.net/publication/292235964_Processing_of_Fecal_Sludge_to_Fertilizer_Pellets_Using_a_Low-Cost_Technology_in_Ghana
- Nong, H. T. T., Unpaprom, Y., Whangchai, K., & Ramaraj, R. (2020). Sustainable valorization of water primrose with cow dung for enhanced biogas production. *Biomass Conversion and Biorefinery*, 19(7), 234-250.
https://www.researchgate.net/publication/344553533_Sustainable_valorization_of_water_primrose_with_cow_dung_for_enhanced_biogas_production
- NYEWASCO, (2007). Nyeri Water and Sewerage Company Website. www.nyewasco.co.ke, Retrieved (online) February 2020. <http://www.nyewasco.co.ke/>
- Okalebo, J. R., Gathua, K. W., & Woome, P. L. (2002). Laboratory methods of soil and plant analysis: a working manual second edition. *Sacred Africa, Nairobi*, 21.
<https://www.researchgate.net/file.PostFileLoader.html?id=5882f0c8ed99e15dce797d03&assetKey=AS%3A452837697167361%401484976328229>
- Okoh, A. I., Sibanda, T., & Gusha, S. S. (2010). Inadequately treated wastewater as a source of human enteric viruses in the environment. *International Journal of Environmental Research and Public Health*, 7(6), 2620-2637.
<https://pubmed.ncbi.nlm.nih.gov/20644692/>
- Orodho, A. (2001). KARI Regional Research Centre, ~~PO box 169~~, Swiftkisumu. com. In *Proceedings of the International Grassland Congress*, Vol. 19, Issue 3, p. 415.
- Osagie, I. (2019). *A study of biogas generation from poultry litter and its impurity removal* (Doctoral dissertation).
https://openscholar.dut.ac.za/bitstream/10321/3537/3/Thesis%20Mine_Final_ThesisFi

[nal%20lazarus%2018TH%20%20Finalxxies%20for%20last%20graduation_Redacted.pdf](#)

- Otawa, K., Lee, S. H., Yamazoe, A., Onuki, M., Satoh, H., & Mino, T. (2007). Abundance, diversity, and dynamics of viruses on microorganisms in activated sludge processes. *Microbial Mycology*, 53(1), 143-152. <https://www.phageguard.com/wp-content/uploads/2016/12/Otawa-K-Lee-SH-Yamazoe-A-Onuki-M-Satoh-H-Mino-T.-2007-Abundance-diversity-and-dynamics-of-viruses-on-microorganisms-in-activated-sl.pdf>
- Pandur, Ž. &, & Stopar, D. (2021). *Evolution of mechanical stability from lipid layers to complex bacterial envelope structures*. (Vol. 33). London: Academic Press. Retrieved september 22, 2022, from <https://ouci.dntb.gov.ua/en/works/7B0wOL6l/>
- Papadopoulos, A., Parisopoulos, G., Papadopoulos, F., & Karteris, A. (2003). Sludge accumulation pattern in an anaerobic pond under Mediterranean climatic conditions. *Water Research*, 37(3), 634-644. <https://pubmed.ncbi.nlm.nih.gov/12688698/>
- Park, H. D., Wells, G. F., Bae, H., Criddle, C. S., & Francis, C. A. (2006). Occurrence of ammonia-oxidizing archaea in wastewater treatment plant bioreactors. *Applied and Environmental Microbiology*, 72(8), 5643-5647. <https://pubmed.ncbi.nlm.nih.gov/16885322/>
- Phan, H. V., Wickham, R., Xie, S., McDonald, J. A., Khan, S. J., Ngo, H. H., & Nghiem, L. D. (2018). The fate of trace organic contaminants during anaerobic digestion of primary sludge: A pilot scale study. *Bioresource Technology*, 256, 384-390. <https://ro.uow.edu.au/cgi/viewcontent.cgi?article=2118&context=eispapers1>
- Pierre, B., & Wright, A. D. G. (2013). Metagenomic analysis of methanogen populations in three full-scale mesophilic anaerobic manure digesters operated on dairy farms in Vermont, USA. *Bioresource Technology*, 138, 277-284. <https://pubmed.ncbi.nlm.nih.gov/23624045/>
- Poquet, V., Papirio, S., Steyer, J. P., Trably, E., Escudié, R., & Esposito, G. (2018). High-solids anaerobic digestion model for homogenized reactors. *Water research*, 142, 501-511. https://www.researchgate.net/publication/325762505_High-solids_anaerobic_digestion_model_for_homogenized_reactors
- Pyzik, A., Cieczkowska, M., Krawczyk, S., Sobczak, A., Drewniak, L., Dziembowski, A., & Lipinski, L. (2018). Comparative analysis of deep sequenced methanogenic

- communities: identification of microorganisms responsible for methane production. *Microbial cell factories*, 17(1), 1-16.
<https://microbialcellfactories.biomedcentral.com/articles/10.1186/s12934-018-1043-3>
- Rajta, A., Bhatia, R., Setia, H., & Pathania, P. (2020). Role of heterotrophic aerobic denitrifying bacteria in nitrate removal from wastewater. *Journal of Applied Microbiology*, 128(5), 1261-1278.
<https://sfamjournals.onlinelibrary.wiley.com/doi/10.1111/jam.14476>
- Ramirez, K. G., Possan, E., Bittencourt, P. R. S., Carneiro, C., & Colombo, M. (2018). Physico-chemical characterization of centrifuged sludge from the Tamanduá water treatment plant (Foz do Iguaçu, PR). *Matéria (Rio de Janeiro)*, 23(3).
- Raschid, L., & Jayakody, P. (2008). Drivers and characteristics of wastewater agriculture in developing countries: *Results From a Global Assessment* (Vol. 127). IWMI.
https://www.researchgate.net/publication/242230848_Drivers_and_Characteristics_of_Wastewater_Agriculture_in_Developing_Countries_Results_from_a_Global_Assessment
- Raschid, L., Carr, R., & Buechler, S. (2005). Managing wastewater agriculture to improve livelihoods and environmental quality in poor countries. *Irrigation and Drainage: The journal of the International Commission on Irrigation and Drainage*, 54(S1), S11-S22. <https://onlinelibrary.wiley.com/doi/abs/10.1002/ird.182>
- Reeve, J. N. (1992). Molecular biology of methanogens. *Annual Review of Microbiology*, 46(1), 165-191.
<https://www.annualreviews.org/doi/abs/10.1146/annurev.mi.46.100192.001121>
- Rehman, M. S. U., Rashid, N., Ashfaq, M., Saif, A., Ahmad, N., & Han, J. I. (2015). Global risk of pharmaceutical contamination from highly populated developing countries. *Chemosphere*, 138, 1045-1055. <https://pubmed.ncbi.nlm.nih.gov/23535471/>
- Ren, T., Patel, M. K., & Blok, K. (2008). Steam cracking and methane to olefins: Energy use, CO₂ emissions and production costs. *Energy*, 33(5), 817-833.
<https://econpapers.repec.org/RePEc:eee:energy:v:33:y:2008:i:5:p:817-833>
- Roopnarain, A., Mukhuba, M., Adeleke, R., & Moeletsi, M. (2017). Biases during DNA extraction affect bacterial and archaeal community profile of anaerobic digestion samples. *3 Biotech*, 7(6), 1-12.
<https://www.ncbi.nlm.nih.gov/pmc/articles/PMC5653670/>

- Rorat, A., Courtois, P., Vandenbulcke, F., & Lemiere, S. (2019) Sanitary and environmental aspects of sewage sludge management, *Industrial and Municipal Sludge*.19: 155–180
<https://www.ncbi.nlm.nih.gov/pmc/articles/PMC7149543/>
- Ruan, X. D., & Liu, J. X. (2013). Analysis of the fractal structure of activated sludge flocs. *Huan jing ke xue= Huanjing kexue*, 34(4), 1457-1463.
<https://www.witpress.com/Secure/elibrary/papers/DN04/DN04034FU.pdf>
- Ryue, J., Lin, L., Liu, Y., Lu, W., McCartney, D., & Dhar, B. R. (2019). Comparative effects of GAC addition on methane productivity and microbial community in mesophilic and thermophilic anaerobic digestion of food waste. *Biochemical Engineering Journal*, 146, 79-87. <https://era.library.ualberta.ca/items/906a6776-37d6-4a42-9a2c-b9bf462da81a/download/e2e3b552-b59b-473f-817a-4ae907496ea8>
- Salvadó, H., Mas, M., Menendez, S., & Gracia, M. P. (2001). Effects of shock loads of salt on protozoan communities of activated sludge. *Acta Protozoologica*, 40(3), 177-186.
<http://citeseerx.ist.psu.edu/viewdoc/download?doi=10.1.1.1079.1030&rep=rep1&type=pdf>
- Samolada, M. C., & Zabaniotou, A. A. (2014). Comparative assessment of municipal sewage sludge incineration, gasification and pyrolysis for a sustainable sludge-to-energy management in Greece. *Waste Management*, 34(2), 411-420.
<https://pubmed.ncbi.nlm.nih.gov/24290971/>
- Santos, S., Costa, C. A., Duarte, A. C., Scherer, H. W., Schneider, R. J., Esteves, V. I., & Santos, E. B. (2010). Influence of different organic amendments on the potential availability of metals from soil: A study on metal fractionation and extraction kinetics by EDTA. *Chemosphere*, 78(4), 389-396. <https://pubmed.ncbi.nlm.nih.gov/19962175/>
- Sartorius, C. (2011). Technology foresight and future opportunities through the development of phosphorus recycling technologies in Germany. In Pinnekamp (Ed.), *Circular economy for plant nutrients*. 14, pp. 12-20. Munich: Austin Macauley publishers. Retrieved from <https://phosphorusplatform.eu/events/75-news-archive/enews/1511-enews14>
- Schifman, L. A., Tryby, M. E., Berner, J., & Shuster, W. D. (2018). Managing uncertainty in runoff estimation with the US Environmental Protection Agency national stormwater calculator. *JAWRA Journal of the American Water Resources Association*, 54(1), 148-159. <https://onlinelibrary.wiley.com/doi/abs/10.1111/1752-1688.12599>
- Segado, A. M., Alarcon, M., Serrana, H. L. G., & Martinez, M. C. (2006). Calcium and magnesium levels in agricultural soil and sewage sludge in an industrial area from

- Southeastern Spain: relationship with plant (*Saccharum officinarum*) disposition. *Soil and Sediment Contamination: An International Journal*, 15(4), 367-377.
<https://www.tandfonline.com/doi/abs/10.1080/15320380600751736>
- Senesi, N., Sposito, G., Holtzclaw, K. M., & Bradford, G. R. (1989). Chemical Properties of Metal-Humic Acid Fractions of a Sewage Sludge-Amended Aridisol. *American Society of Agronomy, Crop Science Society of America, and Soil Science Society of America*. 18 (2)186-194.
<https://access.onlinelibrary.wiley.com/doi/abs/10.2134/jeq1989.00472425001800020010x>
- Seong, C. Y., Yaqub, M., & Lee, S. H. (2020). Cost analysis and effects of various coagulants used for sludge treatment at the full-scale wastewater treatment plant. *Desalination and Water Treatment*, 201, 139-149.
https://www.researchgate.net/publication/344947424_Cost_analysis_and_effects_of_various_coagulants_used_for_sludge_treatment_at_the_full-scale_wastewater_treatment_plant/download
- Seviour, R. J., & Nielsen, P. H. (2010). Microbial communities in activated sludge plants. *Microbial Ecology of Activated Sludge*, 4 (1), 95-126.
<https://vbn.aau.dk/en/publications/microbial-communities-in-activated-sludge-plants>
- Shannon, C. E. (1948). A mathematical theory of communication. *The Bell system Technical Journal*, 27(3), 379-423. <https://onlinelibrary.wiley.com/doi/10.1002/j.1538-7305.1948.tb01338.x>
- Shivsharan, V. S., Kulkarni, S. W., & Wani, M. (2013). Physicochemical characterization of dairy effluents. *International Journal of Life Science and Pharma Research*, 2(2), 182-191.
<http://www.ijlbpr.com/index.php?m=content&c=index&a=show&catid=119&id=288>
- Shrivastava, S. K., & Banerjee, D. K. (1998). Operationally determined speciation of copper and zinc in sewage sludge. *Chemical Speciation & Bioavailability*, 10(4), 137-143.
https://www.researchgate.net/publication/233505283_Operationally_determined_speciation_of_copper_and_zinc_in_sewage_sludge
- Siles, J. A., & Margesin, R. (2016). Abundance and diversity of bacterial, archaeal, and fungal communities along an altitudinal gradient in alpine forest soils: what are the driving factors? *Microbial Ecology*, 72(15), 207-220.
<https://pubmed.ncbi.nlm.nih.gov/26961712/>

- Simpson, E. H. (1949). Measurement of diversity. *Nature*, 163(4148), 688-688.
<https://www.nature.com/articles/163688a0>
- Sims, J. T. (2000). Soil test phosphorus: Olsen P. *Methods Of Phosphorus Analysis For Soils, Sediments, Residuals, and Waters*, 20 (5), 13-23.
<https://sera17dotorg.files.wordpress.com/2015/02/sera-17-methods-for-p-2000.pdf>
- Singh, V., Phuleria, H. C., & Chandel, M. K. (2017). Unlocking the Nutrient Value of Sewage Sludge. *Water and Environment Journal*, 52 (16), 101-115.
<https://onlinelibrary.wiley.com/doi/abs/10.1111/wej.12739>
- Sinha, R. K., Herat, S., Bharambe, G., & Brahmabhatt, A. (2010). Vermistabilization of sewage sludge (biosolids) by earthworms: converting a potential biohazard destined for landfill disposal into a pathogen-free, nutritive and safe biofertilizer for farms. *Waste Management & Research*, 28(10), 872-881.
<https://journals.sagepub.com/doi/10.1177/0734242X09342147>
- Śliz, M., & Wilk, M. (2020). A comprehensive investigation of hydrothermal carbonization: Energy potential of hydrochar derived from Virginia mallow. *Renewable Energy*, 156, 942-950. <https://www.sciencedirect.com/science/article/pii/S0960148120306625>
- Soddell, J. A., & Seviour, R. J. (1990). Microbiology of foaming in activated sludge plants. *Journal of Applied Bacteriology*, 69(2), 145-176.
<https://sfamjournals.onlinelibrary.wiley.com/doi/abs/10.1111/j.1365-2672.1990.tb01506.x>
- Song, C., Li, R., Zhao, Y., Li, R., Ma, D., & Kansha, Y. (2019). Assessment of four sewage sludge treatment routes with efficient biogas utilization and heat integration. *Process Safety and Environmental Protection*, 126, 205-213.
<https://www.sciencedirect.com/science/article/abs/pii/S0957582019306299>
- Spring, S., Jäckel, U., Wagner, M., & Kämpfer, P. (2004). *Ottowia thiooxydans* gen. nov., sp. nov., a novel facultatively anaerobic, N₂O-producing bacterium isolated from activated sludge, and transfer of *Aquaspirillum gracile* to *Hylemonella gracilis*. *International Journal of Systematic and Evolutionary Microbiology*, 54(1), 99-106.
<https://pubmed.ncbi.nlm.nih.gov/14742465/>
- Srinivasarao, C., Veni, V. G., Sharma, K. L., Raju, B. M. K., Pasricha, N. S., & Singh, R. (2015). Phosphorus fertility status and strategies to improve its use efficiency in Indian soils. *Indian Journal of Fertilisers*, 11(3), 22-36.
<https://www.intechopen.com/chapters/76985>

- Stams, A. J., & Plugge, C. M. (2009). Electron transfer in syntrophic communities of anaerobic bacteria and archaea. *Nature Reviews Microbiology*, 7(8), 568-577.
<https://pubmed.ncbi.nlm.nih.gov/19609258/>
- St-Pierre, B., & Wright, A. D. G. (2013). Metagenomic analysis of methanogen populations in three full-scale mesophilic anaerobic manure digesters operated on dairy farms in Vermont, USA. *Bioresource Technology*, 138, 277-284.
<https://pubmed.ncbi.nlm.nih.gov/23624045/>
- Strande, L., & Brdjanovic, D. (Eds.). (2014). Faecal sludge management: Systems Approach For Implementation and Operation. *IWA publishing*, 23 (7), 189-197.
https://www.un-ihe.org/sites/default/files/fsm_book_lr.pdf
- Strittmatter, A. W., Liesegang, H., Rabus, R., Decker, I., Amann, J., Andres, S., & Amann, R. (2009). Genome sequence of *Desulfobacterium autotrophicum* HRM2, a marine sulfate reducer oxidizing organic carbon completely to carbon dioxide. *Environmental Microbiology*, 11(5), 1038-1055. <https://pubmed.ncbi.nlm.nih.gov/19187283/>
- Strong, P. J., Xie, S., & Clarke, W. P. (2015). Methane as a resource: can the methanotrophs add value? *Environmental Science & Technology*, 49(7), 4001-4018.
<https://pubmed.ncbi.nlm.nih.gov/25723373/>
- Suanon, F., Sun, Q., Mama, D., Li, J., Dimon, B., & Yu, C. P. (2016). Effect of nanoscale zero-valent iron and magnetite (Fe₃O₄) on the fate of metals during anaerobic digestion of sludge. *Water Research*, 88, 897-903.
<https://pubmed.ncbi.nlm.nih.gov/26613183/>
- Sun, Y., Li, L., Wang, Y., Xing, T., & Hu, K. (2018). 7 Microbial for Methane Production. *Microbial Energy Conversion*, 3,36.
<https://www.sciencedirect.com/science/article/pii/S2589004220309913>
- Sweeten, J. M. (2008). Composting manure and sludge. *Texas FARMER Collection*.
https://www.researchgate.net/publication/291318954_Composting_manure_and_sludge
- Tafarel, F., Macioski, G., Carvalho, D., Nagalli, A., Freitas, D. C. D., & Passig, F. H. (2016). Evaluation of Concrete Properties due to the Incorporation of Sludge from a Water Treatment Plant. *Matéria (Rio de Janeiro)*, 21 (4), 974-986.
<https://opus.lib.uts.edu.au/bitstream/10453/132819/3/2-s2.0-85062244828.pdf>
- Tafarel, F., Macioski, G., Carvalho, D., Nagalli, A., Freitas, D., & Passig, H. (2016). Evaluation of concrete properties due to the incorporation of sludge from a water

- treatment plant. *Matéria (Rio de Janeiro)* [online]. 2016, vol.21, n.4, pp.974-986. ISSN 1517-7076. <https://doi.org/10.1590/s1517-707620160004.0090>.
- Tamura, K., Glen, S., & Sudhir, K. (2021). MEGA11: molecular evolutionary genetics analysis version 11. *Molecular Biology and Evolution*, 38 (7), 3022-3027. <https://www.ncbi.nlm.nih.gov/pmc/articles/PMC8625754/>
- Tandukar, M., Ohashi, A., & Harada, H. (2007). Performance comparison of a pilot-scale UASB and DHS system and activated sludge process for the treatment of municipal wastewater. *Water Research*, 41(12), 2697-2705. <https://pubmed.ncbi.nlm.nih.gov/17418365/>
- Tandukar, M., Uemura, S., Ohashi, A., & Harada, H. (2006). Combining UASB and the “fourth generation” down-flow hanging sponge reactor for municipal wastewater treatment. *Water Science and Technology*, 53(3), 209-218. <https://europepmc.org/article/med/16605034>
- Thauer, R. K. (1998). *Biochemistry of Methanogenesis: a tribute to Marjory Stephenson: 1998 Marjory Stephenson prize lecture. Microbiology*, 144(9), 2377-2406. <https://pubmed.ncbi.nlm.nih.gov/9782487/>
- Thauer, R. K., Kaster, A. K., Seedorf, H., Buckel, W., & Hedderich, R. (2008). Methanogenic archaea: ecologically relevant differences in energy conservation. *Nature Reviews Microbiology*, 6(8), 579-591. <https://www.nature.com/articles/nrmicro1931>
- Tuomisto, H. (2010). A consistent terminology for quantifying species diversity? Yes, it does exist. *Oecologia*, 164(4), 853-860. <https://pubmed.ncbi.nlm.nih.gov/20978798/>
- Ujang, Z., & Buckley, C. (2002). Water and wastewater in developing countries: present reality and strategy for the future. *Water Science and Technology*, 46 (9), 1-9. <https://iwaponline.com/wst/article/46/9/1/8100/Water-and-wastewater-in-developing-countries>
- United States Environmental Protection Agency (EPA), (2012). *Dissolved Oxygen and Biochemical Oxygen Demand, Water Monitoring & Assessment*. Retrieved from <http://water.epa.gov/type/rsl/monitoring/vms52.cfm>. <https://archive.epa.gov/water/archive/web/html/vms52.html>
- United States Environmental Protection Agency (EPA), (2015). IEEE 802.15.4 Based Water Quality Monitoring System. *International Journal of Advance Research and Innovative Ideas in Education*, 2, 110-116.

http://ijariie.com/AdminUploadPdf/IEEE_802_15_4_based_Water_Quality_Monitoring_System_IJARIIE1149_volume_1_11_page_110_116.pdf

- Vanwongerghem, I., Evans, P. N., Parks, D. H., Jensen, P. D., Woodcroft, B. J., Hugenholtz, P., & Tyson, W. (2016). Methylophilic methanogenesis discovered in the archaeal phylum Verstraetearchaeota. *Nature Microbiology*, 1(12), 1-9.
<https://www.nature.com/articles/nmicrobiol2016170>
- Verheijen, F. G., Zhuravel, A., Silva, F. C., Amaro, A., Ben-Hur, M., & Keizer, J. J. (2019). The influence of biochar particle size and concentration on bulk density and maximum water holding capacity of sandy vs sandy loam soil in a column experiment. *Geoderma*, 347, 194-202. <https://agris.fao.org/agris-search/search.do?recordID=US201900220232>
- Vesilind, P. A. (1994). The role of water in sludge dewatering. *Water Environment Research*, 66(1), 4-11. <https://www.jstor.org/stable/25044401>
- Vincent, S. G. T., Jennerjahn, T. C., & Ramasamy, K. (2021). *Microbial Communities in Coastal Sediments: Structure and Functions*. Elsevier.
<https://www.amazon.com/Microbial-Communities-Coastal-Sediments-Structure/dp/012815165X>
- Vögeli, Y., Riu, C., Gallardo, A., Diener, S., & Zurbrügg, C. (2014). Anaerobic Digestion of Biowaste in Developing Countries: Practical Information and Case Studies. *EAWAG-Sandec: Department of Water and Sanitation in Developing Countries*.
<https://www.dora.lib4ri.ch/eawag/islandora/object/eawag%3A10842>
- von Sperling M(2007) WasteWater characteristics and Disposal, Vol 1, *IWA Publishing*, Alliance House, London
<https://www.iwapublishing.com/sites/default/files/ebooks/9781780402086.pdf>
- Vongvichiankul, C., Deebao, J., & Khongnakorn, W. (2017). Relationship between pH, oxidation reduction potential (ORP) and biogas production in mesophilic screw anaerobic digester. *Energy Procedia*, 138, 877-882.
<https://www.sciencedirect.com/science/article/pii/S1876610217350543>
- Wang, C., Hu, X., Chen, M. L., & Wu, Y. H. (2005). Total concentrations and fractions of Cd, Cr, Pb, Cu, Ni and Zn in sewage sludge from municipal and industrial wastewater treatment plants. *Journal of Hazardous Materials*, 119(1-3), 245-249.
<https://pubmed.ncbi.nlm.nih.gov/15752872/>
- Wang, H., Wang, T., Zhang, B., Li, F., Toure, B., Omosa, I.B., Chiramba, T., Abdel-Monem, M & Pradhan, M. (2014). Water and Wastewater Treatment in Africa Current

- Practices and Challenges, *Clean Soil Air Water*, 42 (8), 1029–1035
<https://onlinelibrary.wiley.com/doi/abs/10.1002/clen.201300208>
- Watanabe, F. S., & Olsen, S. R. (1965). Test of an ascorbic acid method for determining phosphorus in water and NaHCO₃ extracts from soil. *Soil Science Society of America Journal*, 29(6), 677-678.
<https://access.onlinelibrary.wiley.com/doi/10.2136/sssaj1965.03615995002900060025x>
- Water Environment Federation, (2011). Water Environment Federation. Nutrient Removal, *Manual of Practice No. 34*; McGraw-Hill: Alexandria, Virginia.
<https://www.accessengineeringlibrary.com/content/book/9780071737098>
- Weiland, P. (2010). Biogas production: current state and perspectives. *Applied Microbiology and Biotechnology*, 85(4), 849-860. <https://link.springer.com/article/10.1007/s00253-009-2246-7>
- Wilke, B. M. (2005). Determination of chemical and physical soil properties. In *Monitoring and Assessing Soil Bioremediation* (pp. 47-95). Springer, Berlin, Heidelberg.
https://link.springer.com/chapter/10.1007/3-540-28904-6_2
- Wilmes, P., & Bond, P. L. (2006). Metaproteomics: studying functional gene expression in microbial ecosystems. *Trends in Microbiology*, 14(2), 92-97.
<https://pubmed.ncbi.nlm.nih.gov/16406790/>
- World Health Organization. (2006). *The world health report 2006: Working Together for Health*. World Health Organization.
http://whqlibdoc.who.int/publications/2006/9241563176_eng.pdf
- World Health Organization. (2008). *Good Laboratory Practice Training Manual: For the Trainee: A Tool for Training and Promoting Good Laboratory Practice (GLP) Concepts in Disease Endemic Countries*. World Health Organization.
<https://apps.who.int/iris/handle/10665/70191>
- World Health Organization. (2010). *Good Laboratory Practice Training Manual: For the Trainee: A Tool for Training and Promoting Good Laboratory Practice (GLP) Concepts in Disease Endemic Countries*. World Health Organization.
<https://apps.who.int/iris/handle/10665/70191>
- Xu, Z., Hansen, M. A., Hansen, L. H., Jacquiod, S., & Sørensen, S. J. (2014). Bioinformatic approaches reveal metagenomic characterization of soil microbial community. *PLoS*

One, 9(4), e93445.

<https://journals.plos.org/plosone/article?id=10.1371/journal.pone.0093445>

Yang, N., Zhan, G., Li, D., Wang, X., He, X., & Liu, H. (2019). Complete nitrogen removal and electricity production in Thauera-dominated air-cathode single chambered microbial fuel cell. *Chemical Engineering Journal*, 356, 506-515.

<https://www.cabdirect.org/cabdirect/abstract/20193242447>

Yang, X., Zhang, Q., Li, X., Jia, X., Wei, X., & Shao, M. A. (2015). Determination of soil texture by laser diffraction method. *Soil Science Society of America Journal*, 79(6), 1556-1566. <https://access.onlinelibrary.wiley.com/doi/abs/10.2136/sssaj2015.04.0164>

Yergeau, E., Masson, L., Elias, M., Xiang, S., Madey, E., Huang, H., & Beaudette, L. A. (2016). Comparison of methods to identify pathogens and associated virulence functional genes in biosolids from two different wastewater treatment facilities in Canada. *PloS One*, 11(4), e0153554.

<https://journals.plos.org/plosone/article?id=10.1371/journal.pone.0153554>

Zakkour, P. D., Gaterell, M. R., Griffin, P., Gochin, R. J., & Lester, J. N. (2001). Anaerobic treatment of domestic wastewater in temperate climates: treatment plant modelling with economic considerations. *Water Research*, 35(17), 4137-4149.

<https://www.sciencedirect.com/science/article/abs/pii/S0043135401001452>

Zhang, Q., Hu, J., & Lee, D. J. (2016). Biogas from anaerobic digestion processes: Research updates. *Renewable Energy*, 98, 108-119.

<https://ideas.repec.org/a/eee/renene/v98y2016icp108-119.html>

Zhen, G., Lu, X., Kato, H., Zhao, Y., & Li, Y. Y. (2017). Overview of pre-treatment strategies for enhancing sewage sludge disintegration and subsequent anaerobic digestion: current advances, full-scale application and future perspectives. *Renewable and Sustainable Energy Reviews*, 69, 559-577.

<https://www.sciencedirect.com/science/article/abs/pii/S1364032116309352>.

Ziganshin, A. M., Ziganshina, E. E., Kleinstaub, S., & Nikolausz, M. (2016). Comparative analysis of methanogenic communities in different laboratory-scale anaerobic digesters. *Archaea*, 16, 77-80.

<https://www.hindawi.com/journals/archaea/2016/3401272/>

Zorpas, A., Coumi, C., Drtil, M., & Voukalli, I. (2011). Municipal sewage sludge characteristics and waste water treatment plant effectiveness under warm climate

conditions. *Desalination and Water Treatment*, 36(1-3), 319-333.

<https://www.tandfonline.com/doi/abs/10.5004/dwt.2011.2773>

Zorpas, A., Voukkali, I., & Loizia, P. (2013). Proposed treatment applicable scenario for the treatment of domestic sewage sludge which is produced from a sewage treatment plant under warm climates conditions. *Desalination and Water Treatment*, 51(13-15), 3081-3089. <https://ur.booksc.me/book/41641384/8b0f82>

APPENDICES

Appendix A: Statistical analyses for the physico-chemical parameters comparing the raw and the dry beds sludge

No.	Parameters	Shapiro-Wilk normality test	Mann-Whitney U test (p=0.05)	T-test (P=0.05)
1	Bulk density	Passed	N/A	0.004615
2	total carbon	failed	0.0722	N/A
3	EC	passed	N/A	0.0002
4	Moisture	passed	N/A	1
5	particle density	passed	N/A	0.6164
6	PH	passed	N/A	0.000222
7	Porosity	failed	0.0722	N/A
8	Temperature	failed	0.07652	N/A
9	Total Nitrogen	failed	0.184	N/A
10	Texture	failed	0.6193	N/A
11	Total Phosphorous	passed	N/A	0.9653
12	Total solids	passed	N/A	0.05197
13	Volatile solids	failed	0.1	N/A
14	Calcium	failed	0.33333	N/A
15	Copper	failed	0.7366	N/A
16	Iron	failed	0.9997	N/A
17	Potassium	failed	0.9506	N/A
18	Magnesium	failed	0.2593	N/A
19	Sodium	failed	0.2343	N/A
20	Phosphorous	failed	0.1678	N/A
21	Zinc	failed	0.0733	N/A
22	Manganese	failed	0.0986	N/A

Appendix B: PCoA clustering of the composite samples

Sub-groups	Samples	Lagoon
I	2a and 2c	2
II	1b	1
III	1c	1

Appendix C: Composition of top 20 functional categories for all sample(s)

Function	Sample 2a	Sample 2c	Sample 1c	Sample 1b
Cellular Processes	6321	16287	24185	21088
Environmental Information	18745	47756	82072	76063
Processing	31421	81787	126389	113514
Genetic Information Processing	1345	3712	6360	6234
Human Diseases	84748	217758	349788	318862
Metabolism	690	1460	2357	1773
Organismal Systems				

Appendix D: Database sources for the hits distribution

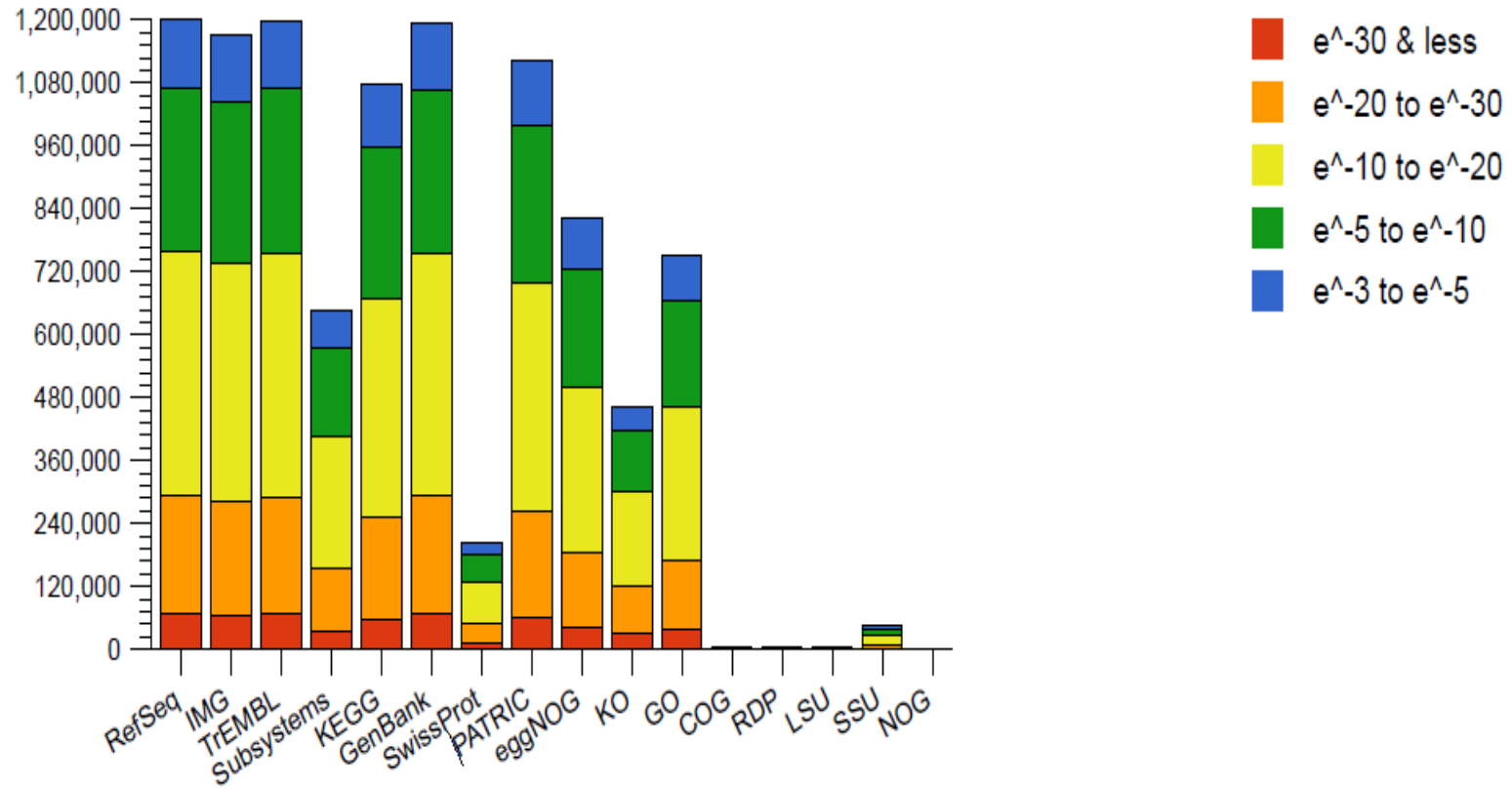

Appendix F: NYEWASCO research permit



Nyeri Water & Sanitation Company Limited (NYEWASCO)
Off Kenyatta Road, Behind Nyeri County Fire Office, P.O. Box 1520-10100 Nyeri, Kenya Tel: 061-2084540/4834620/4817 0928-
401398/0704-788481; Fax: 2082704 Email: info@nyewasco.co.ke Website www.nyewasco.co.ke

Ref: NWSC/IND/II/162/109

Date: 16th June, 2021

Allan Kimisto
Egerton University
P.O Box 536-20115
EGERTON, NAKURU.

0705231583.

Dear Sir,

PERMISSION TO CONDUCT RESEARCH AT NYEWASCO - KANGEMI

Reference is made to your letter dated 16th June 2021 on the above captioned subject.

I am pleased to inform you that your request is granted. You will be required to work with our Technician Incharge Kangemi Treatment works Mr. George Thuita (0726766294).

We look forward to the reviewing the findings on this research engagement.

CHRP. JOYCE MUNIRA
SENIOR HR & ADMIN OFFICER



Chairman – Patrick K. Munube
Board of Directors: Patrick M. Stom, Angela W. Kimaru,
Paul M. Wambugi, Pauline W. Ndegwa,
Veronica W. Maina, Mary W. Mutonyi



Appendix G: Molecular characterisation paper

Heliyon 9 (2023) e15715



Contents lists available at ScienceDirect

Heliyon

journal homepage: www.cell.com/heliyon



Research article

Molecular characterization of microorganisms with industrial potential for methane production in sludge from Kangemi sewage treatment plant, Nyeri county–Kenya



Allan.K. Kimisto^{a,*}, Anastasia W. Muia^a, Geoffrey O. Ong'ondo^a,
Kimani.C. Ndung'u^b

^a Department of Biological Sciences, Egerton University, P.O Box 536- 20115 Egerton, Kenya

^b Kenya Agricultural and Livestock Research Organisation (KALRO), Njoro Station, Private Bag 20107 Njoro, Kenya

ARTICLE INFO

Keywords:

Sewage sludge
Methanogens
Hydrogenotrophic
Acetoclastic
Methylotrophic

ABSTRACT

Microbial consortia under anaerobic conditions are involved in oxidizing organic matter in the sludge to produce methane gas. However, in developing countries like Kenya, these microbes have not been fully identified to target them for the efficient harnessing of biofuel. This study collected wet sludge from two anaerobic digestion lagoons 1 and 2 that were operational during sampling at Kangemi Sewage Treatment Plant, in Nyeri County, Kenya. DNA was extracted from samples using commercially available ZymoBIOMICS™ DNA Miniprep Kit and sequenced using Shotgun metagenomics. Samples were analyzed using MG-RAST software (Project ID: mgp100988), which allowed for identifying microorganisms directly involved in various stages of methanogenesis pathways. The study found hydrogenotrophic methanogens, such as *Methanospirillum* (32%), *Methanobacterium* (27%), *Methanobrevibacter* (27%), and *Methanosarcina* (32%), being predominant in the lagoon communities, whereas acetoclastic microorganisms such as the *Methanoregula* (22%) and the acetate oxidizing bacteria such as *Clostridia* (68%) were the key microbes for that pathway in the sewage digester sludge. Furthermore, *Methanothermobacter* (18%), *Methanosarcina* (21%), *Methanosaeta* (15%), and *Methanospirillum* (13%) carried out the methylotrophic pathway. In contrast, *Methanosarcina* (23%), *Methanoregula* (14%), *Methanosaeta* (13%), and *Methanobrevibacter* (13%) seemed to play an important role in the final step of methane release. This study concluded that the sludge produced from the Nyeri-Kangemi WWTP harbors microbes with significant potential for biogas production. The study recommends a pilot study to investigate the efficiency of the identified microbes for biogas production.

THE PHYSICO-CHEMICAL PROPERTIES OF SEWAGE SLUDGE PROCESSED FOR AGRICULTURAL USE FROM THE NYERI-KANGEMI WASTEWATER TREATMENT PLANT, NYERI COUNTY, KENYA

Authors

Allan Kiptanui Kimisto⁽¹⁾; Geoffrey Odhiambo Ong'ondo⁽²⁾; Anastasia Wairimu Muia⁽³⁾

Main author email: akimisto@gmail.com

(1.2.3) Egerton University, Kenya.

Cite this article in APA

Kimisto, A. K., Ong'ondo, G. O., & Muia, A. W. (2022). The physico-chemical properties of sewage sludge processed for agricultural use from the Nyeri-Kangemi wastewater treatment plant, Nyeri county, Kenya. *Journal of environmental science and technology* 1(1), 37-47. <https://doi.org/10.51317/jest.v1i1.251>



A publication of Editon Consortium Publishing (online)

Article history

Received: 01.06.2022

Accepted: 02.08.2022

Published: 20.09.2022

Scan this QR to read the paper online



Copyright: ©2022 by the author(s). This article is an open access article distributed under the license of the Creative Commons Attribution (CC BY) and their terms and conditions.



Abstract

This study was conducted to assess the physico-chemical properties and changes that occur in the composting process between raw sewage sludge inflow at the sludge tank and the composted end product in the dry beds used for agricultural application at the Nyeri-Kangemi wastewater treatment plant in Nyeri County, Kenya. Sludge samples were collected between June and October in different stages of the sludge treatment process; the sludge tank received from the primary and secondary wastewater treatment processes and the composted sludge from the dry beds. Results showed the final composted dry sludge had a pH ranging from 5.53 to 6.52. The mean values were; EC was 3.77 ± 0.05 mS/cm, TOC of 2.03 ± 0.05 per cent, ON of 0.19 ± 0.01 per cent, TOP 88 ± 1.6 mg/L, Temperature 21.03 ± 0.06 °C, particle density of 2.30 ± 0.02 g/cm³, Bulk density of 0.24 ± 0.02 g/cm³, 90.7 ± 0.01 per cent pore space, moisture content of 11.3 ± 0.70 per cent, TS of 53.40 ± 8.82 per cent and VS of 29.79 ± 9.94 per cent. The concentrations of Fe, Ca, Mg, Mn, K, Na, Zn and Cu were 1896.15 ± 106.2 mg/l, 266.42 ± 27.55 mg/l, 190.52 ± 4.82 mg/l, 139.3 ± 0.29 mg/l, 114.38 ± 4.81 mg/l, 84.61 ± 0.71 mg/l, 39.18 ± 0.36 mg/l and 5.65 ± 0.12 mg/l respectively. This study recommends the need to do more research on how to improve and stabilise the physico-chemical parameters in the sludge treatment before agricultural use.

Key terms: Composted, particle size, sewage sludge, sludge density, total organic carbon.