

**CONSTRUCTION OF GENETIC LINKAGE MAP OF CASSAVA FROM
NACHINYAYA × AR37-80 MAPPING POPULATION USING DNA MARKERS**

BERNADETHA PONDAMALI KIMATA

**A Thesis Submitted to the Graduate School in Partial Fulfillment for the Requirements
of the Degree of Masters of Science in Plant Breeding of Egerton University**

EGERTONUNIVERSITY

Nov, 2012

DECLARATION AND RECOMMENDATION

Declaration

I declare that the research thesis is my original work and not been submitted wholly or in part for any award in any other institution of learning to the best of my knowledge.

Bernadetha Pondamali Kimata

KM12/2806/10

Signature

Date

Recommendation

We wish to confirm that this was done under our supervision and has our approval to be presented for examination as per the Egerton University regulations.

Dr. James Owuoche

Signature.....

Date.....

Department of Crops, Horticulture and Soils Egerton University, Njoro

Dr. Paul Kimurto

Signature.....

Date

Department of Crops, Horticulture and Soils, Egerton University, Njoro

Dr. Geoffrey Mkamilo

Signature.....

Date

Agricultural Research Institute Naliendele, Mtwara, Tanzania

COPYRIGHT

Copy ©2012 Bernadetha P. Kimata

All rights reserved. No part of this work may be reproduced or utilized, in any form or by any means, electronic or mechanical, including photocopying, recording or by any information storage or retrieval system without prior written permission of the author or Egerton University.

ABSTRACT

Cassava brown streak disease (CBSD) is the major constraint in Cassava (*Manihot esculenta*) production in Eastern Africa including Tanzania. Genetic linkage map is a prerequisite for QTL analysis; marker assisted breeding and map-based gene cloning. It is also a prerequisite for the study of inheritance of qualitative and quantitative traits and the molecular information can be applied in marker-assisted selection (MAS). Objectives of this study were to (I) determine heterozygosity of an F₁ population from a cross between Nachinyaya (CBSD tolerant) and AR37-80 (CBSD susceptible) using DNA markers and (ii) develop a SNP-based genetic linkage map of F₁ hybrid derived from a cross between Nachinyaya and AR37-80 to be used in marker-assisted selection (MAS). The leaf samples were obtained from 271 F₁ genotypes planted at Makutupora, Tanzania. Genotyping was done at Biosciences Eastern and Central Africa (BecA) laboratory, Nairobi, by screening 26 SSR markers to identify polymorphic markers against the parental genotypes. The F₁ hybrid integrity was verified to eliminate selfs and off-types using ABI 3730 sequencer and the data analyzed using GeneMapper 4.0 software. Fifteen SSR markers were polymorphic and more informative; however, only 14 markers were used to screen the F₁ genotypes. After ABI 3730 sequencing, 257 F₁ genotypes were found to be true crosses from the two parents. DNA from the 257 F₁ genotypes and the two parents were genotyped at KBioscience using 514 SNP markers. The SNP based genotypic data were used to develop genetic linkage maps using JoinMap[®] 4.1 computer software. Twenty linkage groups that spanned 1697cM with an average distance between the markers of 3.98cM were developed. A total of 217 new SNP markers were mapped for the first time; the markers were not evenly distributed across the linkage groups. However, the number of markers ranged from one (LG20) to 26 (LG8). The results obtained in this research could be useful to identify QTL in Nachinyaya that is associated with CBSD resistance.

Key words: Cassava brown streak disease, Simple sequence repeats, Single nucleotide polymorphism and linkage map.

ACKNOWLEDGEMENT

I wish to appreciate the guidance, encouragement and sacrifice of my supervisors, Dr. James Owuoche, Dr. Paul Kimurto and Dr. Geoffrey Mkamilo and the financial support given by the Generation Challenge Program (GCP) which facilitated the study. The author wishes to appreciate valuable guidance and much sacrifice given by Dr. Morag Ferguson from IITA during molecular analysis and linkage mapping work at Bioscience in Eastern and Central Africa (BecA), Nairobi, Kenya. Appreciation to the Laboratory staffs from IITA and BecA, Arther Karugu and Innosters Nzuki for their technical back-stopping during my training on molecular technique and analysis. The good working environment and valuable cooperation of BecA office is greatly appreciated. Appreciation also goes to KBioscience England for the assistance on SNP genotyping work which facilitated successful completion of the analysis and construction of linkage map. The contribution of the Ministry of Agriculture and Sugarcane Research Institute in Tanzania is appreciated by granting permission to undertake the studies, and also the development of mapping population. The collaboration with the Zonal Director Makutupora Research Institute in Dodoma Tanzania is appreciated for the provision of land for mapping population establishment. Appreciation also goes to Egerton University.

DEDICATION

This thesis is dedicated to my lovely mother Maulicia Malolagi, my husband Seleman Rashid Mnunduma, my children Nurdin Rashid, Awesa Rashid, Naira Rashid, Imonjela Rashid and Zanda Nurdin for their encouragement and patience during my studies. Deus Kimata for taking care of our mother during my absence.

TABLE OF CONTENTS

DECLARATION AND RECOMMENDATION	ii
COPYRIGHT	iii
ABSTRACT.....	iv
ACKNOWLEDGEMENT.....	v
DEDICATION	vi
TABLE OF CONTENTS	vii
LIST OF FIGURES	xi
LIST OF PLATES	xii
LIST OF APPENDICES	xiii
CHAPTER ONE	
INTRODUCTION	1
1.1 Background information	1
1.2 Statement of the Problem.....	2
1.3 Justification.....	2
1.4 Objectives	3
1.4.1 Broad Objective.....	3
1.4.2 Specific Objectives.....	3
1.5 Hypotheses.....	4
1.6 References.....	5
CHAPTER TWO	
LITERATURE REVIEW	7
2.1 Origin of Cassava.....	7
2.2 Economic Importance of cassava	7
2.3 Production Constraints of Cassava	7
2.3.1 Major Diseases of Cassava.....	8
2.3.2 Epidemiology and control of CBSD	8
2.3.3 Feasibility of Virulence Management	10
2.4 Molecular Markers.....	10
2.4.1 The role of molecular markers in cassava breeding	10
2.4.2 Simple Sequence Repeats (Microsatellites) markers	12
2.4.3 Single-Nucleotide Polymorphism (SNP)	12
2.4.4 Expressed Sequence Tag (EST)	13

2.4.5 Restriction Fragment Length Polymorphism (RFLP).....	13
2.4.6 Randomly-Amplified Polymorphic DNA Markers (RAPD)	14
2.4.7 Amplified fragment length polymorphism (AFLP) Markers	15
2.5 Genetic Linkage Maps	15
2.5.1 Cassava Genetic Linkage Maps	17
2.6 KBioscience Competitive Allele-Specific PCR (KASPar) Technology	18
2.7 References.....	20

CHAPTER THREE

Determination of Cassava Hybrids using microsatellite markers.....	25
3.1 Abstract.....	25
3.2 Introduction.....	25
3.3 Materials and Methods.....	26
3.3.1 Genotypes.....	26
3.3.2 Experimental Site	26
3.3.3. Plant Samples	27
3.3.4 DNA Extraction.....	27
3.5 Selection of polymorphic SSR markers for screening F ₁ genotypes	29
3.5.1 DNA Amplification.....	29
3.6 Results.....	29
3.6.1 Selection of polymorphic SSR markers	29
3.7 Discussion.....	45
3.8 Conclusion	46
3.9 References.....	47

CHAPTER FOUR

Construction of a SNP- based genetic linkage map	49
4.1 Abstract.....	49
4.3 Materials and Methods.....	51
4.3.1 Genotyping	51
4.3.2 Detection of cassava hybrids using polymorphic SNP markers	51
4.4 Results.....	52
4.4.1 Linkage mapping.....	52
4.4.2 Construction of genetic linkage maps	53
4.5 Comparison with previous SNP and SSR genetic linkage map.....	55

4.4 Discussion.....	65
4.5 Conclusions.....	67
4.6 Recommendations.....	68
4.7 References.....	69

LIST OF TABLES

Table 1: list of twenty six cassava SSR Markers screened for Polymorphism for variety Nachinyaya and line AR37-80.	33
Table 2: Polymorphic Screening of SSR markers Against Cassava Parental genotypes (Nachinyaya and AR37-80)	35
Table 3: SNP markers and distance assigned to 20 linkage groups of cassava F1 hybrids derived from Nachinyaya × AR37-80.....	54
Table 4: Common SNP markers in Nachinyaya × AR37-80 map and a map of Namikonga × Albert	64
Table 5: Summary of comparison between SNP-based cassava maps in Nachinyaya × AR37-80 (NCAR) map and Namikonga × Albert (NMAL) map.....	65

LIST OF FIGURES

Figure 1: SNP-based genetic linkage map of F ₁ cassava (<i>Manihot esculenta</i> Crantz).....	57
---	----

LIST OF PLATES

Plate 1: DNA profile of some genomic DNA bands that were stained with GelRed for 30 minutes after electrophoresis from cassava F ₁ hybrids developed from Nachinyaya × AR37-80.....	31
Plate 2: Amplified DNA fragments with SSRY 151 marker from 87 Cassava hybrids derived from Nachinyaya × AR37- 80	32
Plate 3: Genotype plot indicating alleles and allele sizes for porlymorphic SSRy171 marker with cassava (<i>Manihot esculenta</i> Crantz) F ₁ hybrids.. Error! Bookmark not defined.	
Plate 4: Genotype plot indicating alleles and allele sizes for polymorphic <i>SSRY171</i> marker with cassava (<i>Manihot esculenta</i> Crantz) F ₁ hybrids.....	36
Plate 5: Genotype plot indicating alleles and allele sizes for polymorphic <i>SSRY63</i> marker with cassava (<i>Manihot esculenta</i> Crantz) F ₁ hybrids.....	37
Plate 6: Genotype plot indicating various alleles and allele sizes for polymorphic marker <i>SSRY5</i> with Cassava (<i>Manihot esculenta</i> Crantz) F ₁ hybrids..	38
Plate 7: Nachinyaya (CBSD tolerant) genotype showing no CBSD leaf symptoms	86
Plate 8: AR37-80 (CBSD susceptible) genotype showing CBSD leaf symptoms	87

LIST OF APPENDICES

Appendix 1: Linkage groups and SNP marker positions.....	72
Appendix 2: Cassava DNA extraction protocol.....	77
Appendix 3: DNA qualification, quantification and dilution to 50ng/μl for working samples	81

ABBREVIATIONS AND ACRONYMS

ACMV	African Cassava Mosaic Virus
AFLP	Amplified Fragment Length Polymorphism
ARI	Agricultural Research Institute
ASAL	Arid and Semi-Arid Lands
BSA	Bulk Segregant Analysis
BecA	Biosciences for Eastern and Central Africa
CBSD	Cassava Brown Streak Disease
CGM	Cassava Green Mite
cM	CentiMorgans.
CMB	Cassava Mealy Bug
CMD	Cassava Mosaic Disease
CTAB	Cetyl tri-methylammonium bromide
DNA	Deoxyribonucleic Acid
EACMV	East African Cassava Mosaic Virus
EDTA	Ethylene diaminetetraacetic acid
EST	Expressed Sequence Tag
FAO	Food Agricultural Organization
GCP	Generation Challenge Program
GQ	Genotype quality
IITA	International Institute of Tropical Agriculture
ILRI	International Livestock Research Institute
KASP	KBiosciences Allele Specific PCR
LG	Linkage group
LOD	Logarithm of Odds
MAB	Marker Assisted Breeding
NCAR	A population derived from a cross between Nachinyaya x AR37-80
NMAL	A population derived from Namikonga x Albert
PCR	Polymerase Chain Reaction
QTL	Quantitative Trait Loci
RAPD	Randomly Amplified Polymorphic DNA
RFLP	Random Fragment Length Polymorphism
RNA	Ribonucleic Acid
SCAR	Sequence Characterized Amplified Regions
SDS	Sodium Dodecyl Sulphate
SNP	Single Nucleotide Polymorphism
SPVD	Sweet Potato Virus Disease
SRAP	Sequence-Related Amplified Polymorphism
SSR	Simple Sequence Repeats
TBE	Tris-Borateethylenediaminetetraacetic Acid
TE	Tris – Ethylene Diaminetetraacetic Acid
UgV	Ugandan Variant

CHAPTER ONE

INTRODUCTION

1.1 Background information

Cassava (*Manihot esculenta* Crantz) is a staple crop for more than 800 million people worldwide (Raji *et al.*, 2009) and 500 million in the developing world. It is one of the most widely grown staple crops in Sub-Saharan Africa with total production of more than 90 million tons, greater than total production for any other crop in Africa (FAO, 2001). The worldwide total cassava production is 242,069,000 metric tons; Africa's total production is 121,469,000 metric tons while Tanzania's cassava production is 6,500,000 metric tons (FAO, 2009). Nigeria, Democratic Republic of Congo, Ghana, Tanzania and Mozambique are among the top ten world producers of cassava (FAO, 2001). Tanzania's average cassava fresh root yield is 8 t ha⁻¹ (Mkamilo and Jeremiah, 2005), this is below the average global cassava production of 12 t ha⁻¹ and the average yield of 9.6 t ha⁻¹ of Africa (FAO, 2009).

Tanzania is the fourth largest producer of cassava in Africa with annual root production of about 5.5 million tons along the coastal belt of Lake Victoria, Tanganyika and Lake Nyasa (Mkamilo and Jeremiah, 2005). The yield gap is caused by low genetic yielding potential of local varieties, biotic and abiotic stresses. Abiotic stresses include low soil fertility, poor edaphic factors and drought. Biotic stresses include cassava brown streak disease (CBSD), East African Cassava Mosaic Virus disease (EACMV) and its Ugandan variant strain (UgV); and the African Cassava Mosaic Virus (ACMV). Others are Cassava Bacterial Blight (CBB) and major pests such as Cassava Green Mite (CGM) and Cassava Mealy Bug (CMB). Cassava brown streak disease is devastating; it was reported earlier in the coastal areas of Tanzania and Malawi. However, the disease spread is increasing to the inlands in Tanzania, Uganda, Kenya and Malawi (Winter *et al.*, 2010) and central Africa (Alicai *et al.*, 2007; Ntawuruhunga and Legg 2007; FAO, 2010; Mohammed *et al.*, 2011 and Yadav *et al.*, 2011). So far no known variety that is tolerant to the disease has been developed. The knowledge of molecular markers linked to CBSD resistance will be useful to efficiently move resistant genes to farmer-preferred but susceptible varieties using marker assisted-breeding (MAB).

Cassava belongs to *Euphorbiaceae* family containing 28 wild species and its evolution is from inter-specific hybridization among wild species (Lekha *et al.*, 2011). It is an out crossing crop, consequently highly heterozygous and because of its out crossing nature, 91.5% genetic variation exists in cassava germplasm. In a diploid cassava ($2n=36$), DNA content is approximately 1.7pg (picogram per cell nucleus) and the haploid genome size is approximately 772 mega base pairs (Mbp) (Lekha *et al.*, 2011).

The genetic linkage map has been used for genetic studies in many crops like Wheat (*Triticum aestivum*) (Erayman *et al.*, 2004), Sunflower (*Helianthus annuus*), Barley (*Hordeum vulgare*), Cotton (*Gossypium hirsutum*), Oat (*Avena sativa*), Tobacco (*Nicotiana tabacum*), and Tomato (*Lycopersicon esculenta*), Soybean (*Gycine max*) Others include Common beans (*Phaseolus vulgaris*), Sorghum (*Sorghum bicolor*) (Mace *et al.*, 2009), Rice (*Oryza sativa*) (Srividya *et al.*,2010) and Cassava (*Manihot esculenta* Crantz) (Jorge *et al.*, 2000) against bacterial blight (*Xanthomonas campestris* pathovar manihotis).

1.2 Statement of the Problem

Although cassava has the potential of being the leading food crop of approximately 500 million people in developing world, its production and adoption is constrained by several biotic factors including cassava brown streak disease (CBSD). The disease affects root quality, foliage and stems and under severe infection, it causes stem dieback. Affected roots are unsuitable for consumption and produce low quality industrial products such as starch (Ntawuruhunga and Legg, 2007). Use of chemicals and cultural phytosanitary strategies has been proposed to control whitefly insect pests suspected to be vectors of CBSD, but it is not cost effective and not environmentally sustainable. Use of clean planting materials and tissue culture materials is a viable option in minimizing the effect and spread of the disease. However, these strategies are not practical in controlling cassava brown streak virus disease and to date no CBSD resistant varieties are available to be used by farmers. Nachinyaya is one of the tolerant varieties available in Tanzania; however no QTL for CBSD tolerance has been identified.

1.3 Justification

Cassava brown streak disease affects the root quality and decreases yield frequently by 74% and up to 100% under severe infection (Munga, 2002). Other scientists reported that CBSD suppresses yield by 30%-85% (Hillocks and Jennings 2003; Yadav *et al.*, 2011). It also affects foliage and stems and it also causes stem die back which may lead to plant death

under severe infection. Breeding for resistant varieties is the major approach in controlling cassava brown streak disease. Generally conventional breeding by recurrent selection has not been successful in production of disease resistance cultivars because of the environmental effects. However, the process takes long period of time about 6-8 years and is less precise. The cycles of cassava selection uses phenotypic traits and is sometimes influenced by environmental conditions (Ceballos *et al.*, 2007). Therefore application of genetic markers would be the most appropriate method of improving accuracy of selection, reduced environmental influence and breeding cost and reduced breeding period by 4 years (Anthony and Ferroni, 2011). Molecular markers are precise since the genes associated with a particular trait can be identified at the seedling stage and evaluation is done only for genotypes with a gene for the desired trait. However, marker assisted breeding techniques that can be applied effectively in breeding programs to control CBSD are still limited and poorly understood especially in developing countries. Before MAS can be applied in a breeding program, identification of molecular markers associated with a trait of interest must be done. These are identified through quantitative trait loci (QTL) and phenotypic studies; in which development of a genetic linkage map from a segregating population is a prerequisite. However, no genetic linkage map associated with CBSD resistance is available to date. It would be necessary to develop genetic linkage maps using DNA markers. Linkage map is a pre-requisite for QTL mapping for CBSD tolerance in future research.

1.4 Objectives

1.4.1 Broad Objective

To contribute to improved cassava brown streak disease (CBSD) resistance in elite Tanzanian cassava genotype for improved productivity and income generation.

1.4.2 Specific Objectives

- i. To determine heterozygosity of an F₁ population from a cross between Nachinyaya (CBSD tolerant) and AR37-80 (CBSD susceptible) using DNA markers.
- ii. To develop a SNP-based genetic linkage map of F₁ hybrid derived from a cross between Nachinyaya and AR37-80 to be used in marker-assisted selection (MAS).

1.5 Hypotheses

- i. The heterozygosity from recombination frequency of F_1 population for CBSD tolerance derived from Nachinyaya \times AR37-80 cross has not been determined using DNA markers.
- ii. There is no DNA-marker based linkage map for CBSSD tolerance of F_1 hybrids from a cross between Nachinyaya and AR37-80 to be used for MAS.

1.6 References

- Alicai, T., Omongo, C.A., Maruthi, M.N., Hillocks, R.J Baguma, Y., Kawuki, R., Bua, A., Otim-Nape, G.W and Colvin, J. 2007. Re-emergence of cassava brown streak disease in Uganda. *Plant Dis*, 91:24-29. Anthony, V.M and Ferroni, M. 2011. Agricultural biotechnology and smallholder farmers in developing countries. Elsevier Ltd. *Current Opinion in Biotechnology*, 23:1-8.
- Antony, V. and Feroni, M. 2011. Agricultural biotechnology and smallholder farmers in developing countries. *Current Opinion in Biotechnology*, 23:1-8.
- Ceballos, H., Fregene, M., Pérez, J.C., Morante, N., Calle, F. 2007. Cassava Genetic Improvement In: Breeding major food staples (Kang M.S., Priyadarshan PM., eds.), Blackwell Publishing. Ames, IA. USA, pp, 365-391.
- Erayman, M., Sandhu, D., Sidhu, D., Dilbirligi, M., Baenziger, P.S and Gill, K.S., Gill. 2004. Demarcating the gene-rich regions of the wheat genome. *Oxford Journals. Nucleic Acid Research*, 32: 3546-3565.
- FAO. 2001. Food and Agricultural Organization Production Year Book. Rome, Italy.
- FAO. 2009. Food outlook. Global Market Analysis.
- FAO. 2010. Cassava virus a verge of epidemic in East Africa.
- Hillocks, R.J. and Jennings, D.L. 2003. Cassava brown streak disease: a review of present knowledge and research needs. *International Journal of Pest Management*, 49:225-234.
- Jorge, V., Fregene, M.A., Duque, M.C., Bonierbale, M.W., Tohme, J., Verdier, V. 2000. Genetic mapping of resistance to bacterial blight disease in cassava (*Manihot esculenta* Crantz). *Biomedical and Life Sciences*, 101:865-872.
- Lekha, S.S., Teixeira da Silva, J. A and Pillai, S.V. 2011. Genetic variability studies between released varieties of cassava and central Kerala cassava collections using SSR markers. *Journal of Stored products and Postharvest Research*, 2:79-92.
- Mace, E.S., Rami, J., Bouchet, S., Klein, P. E., Lein, R.R., Kilian, A.P., Wenzl, P., Xia, L., Halloran, K and Jordan, D.R. 2009. A consensus genetic map of sorghum that integrates multiple component maps and high-throughput diversity array technology (DArT) markers. *BMC Plant Biology*, 9:13.
- Mkamilo, G.S and Jeremiah, S.C. 2005. Current status of cassava improvement programme in Tanzania. *African Crop Science Proceedings*, 7:1311-1314.
- Muhammed, I.U., Abarshi, M.M., Muli, B., Hillocks, R.J and Maruthi, M.N. 2011. The symptoms and genetic diversity of cassava brown streak viruses infecting cassava in East Africa. *Advances in Virology*, 2012:1-10.
- Munga, T and Thresh, J.M. 2002. Incidence of cassava mosaic and cassava brown streak virus diseases in coastal Kenya. *Roots* 8:13-14.
- Ntawuruhunga, P and Legg, J. 2007. New spread of cassava brown streak virus disease and its implication for the movement of cassava germplasm in the eastern and central African region <http://c3project.iita.org/Doc/A25-CBSDLbriefMay6.pdf>.
- Raji, A.A.J., Anderson, J.V., Kalade, O.A., Ugwu, C.D., Dixon, G.O and Ingelbrecht, I.L. 2009. Gene based microsatellite for cassava (*Manihot esculenta* Crantz): Prevalence polymorphisms and cross-taxa utility. *BMC Plant Biology*, 9:118.
- Srividya, S., Vermireddy, L.R., Haniprasad, A.S., Jayaprad, M., Sridhar, S., Ramanarao, P.V., Anuradha, G and Siddiq, E.A. 2010. Identification and mapping of landraces derived QTL associated with yield and its components in rice under different nitrogen levels and environments. *International Journal of Plant Breeding and Genetics*, 4:210-227.

- Winter, S., Koebler, M., Stein, B., Pietruszka, A., Paape, M and Butgereitt, A. 2010. The analysis of cassava brown streak virus reveals the presence of distinct virus species causing cassava brown streak disease in East Africa. *J. Gen. Virol*, 91:1365-1372.
- Yadav, J., Ogwok' E., Wagaba, H., Patil B, L., Bajewadi, B., Alicai, T., Gaitaan-Solis, N., Taylor, N., and Fauquat, C. 2011. RNAi-mediated resistance to cassava brown streak Uganda virus in transgenic cassava. *Molecular Plant Pathology Journal*, 12:677-687.

CHAPTER TWO

LITERATURE REVIEW

2.1 Origin of Cassava

Cassava (*Manihot esculenta* Crantz) has the minor and major centers of origin. Central America including Colombia, Venezuela, Guatemala and Southern Mexico is the minor centre of origin for cassava (Oslen and Schaal) while Brazil is the major center of origin (Ekanayake *et al.*, 1997). *Manihot species* found in the Central America region are distantly related to cassava as compared to those found in Brazil (Roa *et al.*, 1997). Oslen and Schaal, (1999) found that cassava domestication was based on haplotypes of single-copy nuclear gene glyceraldehyde 3-phosphate dehydrogenase (*G3pdh*) in cassava and its relatives and domestication was from wild *Manihot esculenta*.

2.2 Economic Importance of cassava

Cassava is the sixth most important crop after wheat (*Triticum aestivum*), rice (*Oryza sativa*), maize (*Zea mays*), potato (*Solanum tuberosum*), and barley (*Hodeum vulgare*) and a staple crop for more than 800 million people worldwide (Lebot, 2009). The storage roots form the basic carbohydrate component of the diet and leaves contain appreciable amounts of vitamins, minerals and proteins. Leaves are consumed as green vegetables in many parts of Africa (Hahn *et al.*, 1989; Westby, 2002; Achidi *et al.*, 2005). Cassava can do well in areas with annual rainfall less than 600mm in semi- arid tropics to greater than 1,500 mm in sub-humid and humid tropics and from sea level to 1,800 meters above sea level (FAO, 2007; Akinpelu *et al.*, 2011).

2.3 Production Constraints of Cassava

Abiotic stresses for cassava production are drought and poor soil fertility; while biotic constraints include diseases and pests. Inadequacy of improved cassava varieties is another constrain to its production. Cassava brown streak and cassava mosaic diseases are the two major biotic stresses, however, cassava bacterial blight is of less importance if compared with the two diseases. Cassava green mite (*Monochellus tanajoa*)(CGM) and cassava mealybug (*Phenacoccus manihoti*) (CMB) are major pests. Pests and diseases in Africa reduce crop yield by 48 million tons annually, approximately 50% of production

(FAO, 2003). CBSD is a big threat to cassava production in Tanzania and East African regions due to its increasing spread to inland areas from coastal areas. This disease interferes with the starch content and quality in the tubers, resulting in low tuber yield and poor root quality.

Because of significant effects of CBSD and CMD diseases, there is an urgent need to develop resistant varieties. Other methods for controlling virus diseases include (i) development of *in vitro* propagation plants (Thro *et al.*, 1999; Alleman *et al.*, 2004) (ii) inspection of healthy cuttings (Thresh and Cooter, 2005) and development of molecular diagnostic techniques for detection of virus infection at early plant stages (Monger *et al.*, 2001). (iii) roguing of infected plants to reduce density of diseased plants and vector populations in the field (Palumbo *et al.*, 2001; Thresh and Cooter, 2005).

2.3.1 Major Diseases of Cassava

In Africa, cassava mosaic disease (CMD) and cassava brown streak disease (CBSD) are the major constraints. Prevalence of cassava brown streak disease (CBSD) in coastal Tanzania is threatening cassava production, because of its damaging nature on cassava roots (Lebot, 2009). The disease was first observed in the 1930s at the Amani Research Institute in Tanzania (Storey, 1936). CBSD is the most devastating disease that causes great losses to root production and quality in coastal areas of Tanzania, Kenya, and Mozambique and in the lakeshores of Malawi (Storey and Nichols, 1938). Although the disease has been thought to be confined to low altitudes of the coastal areas of the Indian Ocean, recent reports show that CBSD is spreading beyond coastal areas and is now found in high altitude areas around Lake Victoria areas of Tanzania, Kenya and Uganda and has been reported in Rwanda, DRC and Congo. A high yield loss of 70% to 100% under severe infection was reported by a recent disease survey conducted in North Eastern, Tanzania (Muhanna and Mtunda, 2002). CBSD causes root necrosis accompanied by root constrictions symptoms.

2.3.2 Epidemiology and control of CBSD

CBSD is caused by Cassava brown streak virus (CBSV) Ipomovirus: Potyviridae (Monger *et al.*, 2001; Mbanzibwa *et al.*, 2009) and CBSV particles are sub-microscopic flexuous rods, approximately 750nm in length. Whitefly (*Bemisia tabaci*) as a vector

suspected to be responsible for viral spread from diseased plant to healthy ones. Selection of clean planting materials is not effective practice under high disease pressure zone, and rouging can be effective when disease incidence is low; however, the disease is often present at high incidences. The use of resistant cultivars is the only effective method to minimize infection

All parts of cassava plants, may show CBSD symptoms however, the disease syndrome and degree of manifestation depends on environmental conditions, growth stage, time of infection and cultivar sensitivity (Hillocks and Thresh, 2000). Nichols (1950) identified two types of leaf symptoms; (i) Chlorosis that appears first along the margins of secondary veins and later affects tertiary veins and may develop into chlorotic blotches, (ii) Appearance of chlorosis with roughly circular patches between the main veins. In advanced stages of the disease much of the lamina may be affected (Hillocks and Thresh, 2000). Stem symptoms are present in advanced stages of the disease and they often indicate presence of root symptoms. Remarkably, stem symptoms are not consistently associated with CBSD root necrosis, except in more sensitive varieties (Hillocks and Thresh, 2000). On young green stem tissues, purple or brown lesions may be observed on exterior surface and may penetrate into the cortex. Under severe infection, death of dormant axillary buds, shrinkage of nodes and finally death of the internodal tissue occur. Branches may die from “die-back” and later causes death of the whole plant.

Root symptom is one of CBSD characteristics in some cultivars and is the most destructive one. In some cultivars root necrosis develop at 8 months after planting infected cuttings despite early appearance of clear foliar symptoms (Katinila *et al.*, 2003). Root morphological symptoms appear as radial constrictions, pits and fissures in the bark surface (Hillocks and Thresh, 2000). Tissues surrounding pits are stained brown or black and below the pits there is necrotic cortex. Internal symptoms consist of yellow or brown, corky necrosis of the starch-bearing tissue sometimes has black streaks (Bua and Namara, 2009). The lesions remain discrete; however, in sensitive varieties almost the whole starch storage tissue may be affected.

2.3.3 Feasibility of Virulence Management

In vitro propagation of sweet potato (*Ipomea batatus* L) (Feng *et al.*, 2000) and cassava (Thro *et al.*, 1999; Alleman *et al.*, 2004) is an important strategy in controlling diseases however, the cost of production of tissue culture materials is high and requires technical knowledge. The use of tolerant varieties is not a permanent solution for cassava brown streak disease because the varieties are not disease immune and crop yield is not suppressed (Calvert and Thresh, 2002). The most feasible solution is the use of disease resistant varieties developed through marker-assisted breeding (MAB). Molecular markers have been used for identification of functional genes and assessment of genetic diversity for many crops (Peleman and Van der Voot, 2003).

2.4 Molecular Markers

Molecular markers are DNA sequence that are readily detected and whose inheritance can be monitored and are useful based on polymorphism and forms the basis to design strategies to exploit for applied purposes (Rosyara and Joshi, 2008). DNA markers must be polymorphic and efficient for evaluation and selection of genotypes. DNA markers segregate as a single gene, and are not affected by the environment (Kumar *et al.*, (2009). Some molecular markers are used for fingerprinting, and characterization of genotypes (Rosyara, 2006). Natural genetic variation of individuals and polymorphic genetic sequences proves the importance of using markers (Kumar, 2009). Molecular markers provide a choice of co-dominant markers that discriminate heterozygotes from homozygotes or dominant markers identified as present or absent sub-classes (Botstein *et al.*, 1980; Williams *et al.*, 1990).

2.4.1 The role of molecular markers in cassava breeding

The cassava genetic improvement can be done efficiently by using easily assayable molecular markers which facilitate identification of genotypes without confounding environmental effects and therefore increasing heritability. Marker-assisted selection (MAS) facilitate efficient reduction of large breeding populations at seedling stage through ‘minimum selection approach’; this is an important technique in cassava because of its long growing cycle and the cost incurred during the evaluation process (Blair *et al.*, 2006). The breeding population can be reduced to 50% for a trait controlled by single gene and up to 87.5% for a trait controlled by three genes (Blair *et al.*, 2006).

Molecular markers have made great contribution to genetics and breeding of cassava in taxonomical studies assessment of genetic diversity, phylogenetic relationships in the genus, and confirmation of ploidy level and development of genetic maps (Fregene *et al.*, 2001). Molecular markers are powerful tools for marker assisted selection (MAS) in plant breeding (Ribaut and Hoisington, 1998; Collard and Mackill, 2008; Sraphet *et al.*, 2011). Marker assisted selection is highly efficient, effective, reliable and cost effective than conventional breeding (Collard *et al.*, 2005), however, the best results are achieved when MAS is combined with phenotypic data compared to either approach independently (Hospital *et al.*, 1992). Elias *et al.*, (2000), applied amplified fragment length polymorphism (AFLP) molecular markers to assess cassava (*Manihot esculenta* Crantz) genetic variability and confirmed that domesticated cassava in Guyana were more similar to the Brazilian wild cassava than the wild cassava in Guyana.

Molecular markers such as isozymes, random fragment length polymorphism (RFLPs), randomly amplified polymorphic DNA (RAPDs), simple sequence repeats (SSRs) and expressed sequence tags (ESTs) have been applied in the construction of cassava framework map which consisted of two geographical divergent parents (Fregene *et al.*, 1997). The international Center for tropical agriculture (CIAT) used multiple flanking markers for selection of dominant gene CMD2 for CMD virus resistance. The CMD2 is also important in the introgression of CGM and cassava brown streak (CBS) resistance from wild relative, *Manihot esculenta* sub specie *flabellifolia*. Over 800 available SSR markers have been used successfully in genetic diversity assessment of different cassava populations (Fregene *et al.*, 1997; Montero *et al.*, 2011). Molecular markers systems include, restriction fragment length polymorphism (RFLP), randomly amplified polymorphic DNA (RAPD), amplified fragment length polymorphism (AFLP), sequence characterized amplified regions (SCAR), microsatellites or simple sequence repeats (SSR), expressed sequence tags (EST) and single nucleotide polymorphism (SNP)(FAO, 2003).The presence of detailed maps and probes for genes of known function, are useful in the discovery of close linkages of molecular marker with a trait of interest (James *et al.*, 2001) and this information has been used to transfer genes from one genetic background to the other in many crops.

2.4.2 Simple Sequence Repeats (Microsatellites) markers

Simple sequence repeats (SSR) markers are present in genomes of most eukaryotic species and are randomly distributed throughout the genome (Collard *et al.*, 2005; Kumar *et al.*, 2009). These are ideal DNA markers for genetic mapping and population studies because of their abundance and are arranged tandemly in repeats of two to five nucleotides long (Roa *et al.*, 2000). Dinucleotide repeats (AT/TA)_n and (GA/CT)_n are the most common repeats in higher plants (Roa *et al.*, 2000). SSR polymorphism levels exist among individuals as a result of variations in the short repeat units (Mittal and Dubey, 2001). Regions flanking microsatellite are conserved among genotypes of the same species and the Polymerase chain reaction (PCR) amplification of SSRs requires designed specific primers on flanking regions of the SSRs (Roa *et al.*, 2000). Multiple microsatellites can be multiplexed during PCR or gel electrophoresis if allele sizes of different loci do not overlap (Ghislain *et al.*, 2004). These markers have been applied for characterization of genetic resources (Roa *et al.*, 2000; Fregene *et al.*, 2003; Okogbenin and Fregene 2006).

2.4.3 Single-Nucleotide Polymorphism (SNP)

SNP markers are DNA sequence variation occurring when a single nucleotide - A, T, C, or G - in the genome differs between members of a species or between paired chromosomes in an individual. SNPs are most abundant type of DNA polymorphism in animal and plant genome and are new source of markers useful in genetic mapping, QTL mapping, map-based positional cloning and assessment of genetic distances between individuals (Lopez *et al.*, 2005). SNP genotyping refers to measurement of genetic variations of single nucleotide polymorphisms (SNPs) between members of a species. SNPs are useful in the analysis of quantitative trait loci (QTL), and in association studies, because they are conserved during evolution of plants and animals. SNPs can also provide genetic fingerprint to be used for identity testing (Raprey and Harbron, 2004). SNPs have been used in detection of gene mutation using gene sequence information for primer construction (Kumar *et al.*, 2009). SNPs are biallelic and therefore less informative than SSR markers. However, the problem is compensated by their abundance and suitability to ultra-high throughput genotyping techniques (Rafalski, 2002; Appleby *et al.*, 2009). SNPs are numerous and can be highly polymorphic when defined on the haploid level of 500-1000bp

DNA length, highly transferable if assayed for conserved orthologous set genes (Fulton *et al.*, 2002). SNPs can be restricted to the coding region and allow quantitative trait nucleotide (QTN) studies and can also be co-dominant. Aspects like sensitivity, accuracy, reproducibility, capability of multiplexing for high throughput analysis, cost effective, flexibility for uses apart from SNP discovery and time consumption for analysis should be considered for genotyping purposes as no single protocol meets research needs (Korzun 2003; Semagn *et al.*, 2006).

2.4.4 Expressed Sequence Tag (EST)

Expressed sequence tags are small copies of DNA sequence (200 to 500 nucleotides long), generated by sequencing one or both ends of an expressed gene (Ayeh, 2008). A detailed EST-based map in two *Brassica oleracea* and four *Arabidopsis thaliana* was constructed (Lan *et al.*, 2000). EST markers have been identified in *Oryza* and *Arabidopsis*, where thousands of functional complementary deoxyribonucleic acids (cDNA) clones are being converted to EST markers (Jaemin *et al.*, 2011).

2.4.5 Restriction Fragment Length Polymorphism (RFLP).

2.4.5.1 RFLP Marker Genotyping

RFLP is a difference in homologous DNA sequences detected by presence of fragments of different lengths after digestion of particular DNA samples with specific restriction endonucleases. RFLP genotyping differentiates organisms by analyzing patterns derived from cleavage of their DNA (Kumar *et al.*, 2009). The technique has been used in gene mapping studies due to their highly genomic abundance throughout the genome and availability of different restriction enzymes (Van den Boch *et al.*, 2007).

2.4.5.2 Segregation and Linkage of RFLP Markers

This technique is based on restriction enzymes and reveals a pattern differences between DNA fragment sizes in individual organisms. Two individuals from the same species have almost identical genomes; however they always differ at a few nucleotides because of translocation, inversion, point mutation, insertion, deletion, and duplication (Kumar *et al.*, 2009). Specific banding patterns are observed by hybridization with labeled

probes that are species-specific single locus probes of 0.5–3.0 kb size obtained from a cDNA library or genomic library (Kumar *et al.*, 2009). Genomic libraries are easy to construct including majority of sequence types; however, a large number of interspersed repeats are found in inserts that detect large number of restriction fragments forming complex patterns (Kumar *et al.*, 2009). In plants, the problem is overcome by use of methylation-sensitive restriction enzyme *Pst*I to obtain low copy DNA sequences of small fragment sizes preferred in RFLP analysis (He *et al.*, 2011; Boyko and Kovalchuk, 2010). The application of RFLPs have been restricted by large amount of pure DNA required for restriction digestion and southern blotting, it also requires radioactive isotope which makes the analysis relatively expensive and hazardous (Kumar *et al.*, 2009). Assay is time-consuming, labor-intensive and only one out of several markers may be polymorphic, this is inconvenient to crosses between closely-related species.

2.4.6 Randomly-Amplified Polymorphic DNA Markers (RAPD)

In 1991, Welsh and McClelland developed a new PCR-based genetic assay, the randomly amplified polymorphic DNA (RAPD) and detected nucleotide sequence polymorphisms in DNA using single primer of arbitrary nucleotide sequence (Kumar *et al.*, 2009). A single species of primer anneals to genomic DNA at two different sites on complementary strands of DNA template within an amplifiable range of each other, and a discrete DNA product is formed through thermo cyclic amplification. However, due to random nature of DNA amplification with random sequence primers, it is important to optimize and maintain consistent reaction conditions for reproducible DNA amplification (Bardarkci, 2000). RAPD are dominant markers and they have limitations in their use for mapping, the problem can be overcome by selecting markers linked in coupling. RAPD assay has been used by several groups as efficient tools for identification of markers linked to agronomic important traits introgressed during the development of near isogenic lines (Kumar *et al.*, 2009). RAPD markers are not commonly used due to poor reproducibility, incoherent products, and difficulties in scoring bands, leading to inappropriate inferences, they are not commonly used. This marker was preferred for genome of a plant in species that were not yet fully studied / sequenced.

2.4.7 Amplified fragment length polymorphism (AFLP) Markers

AFLP is a PCR-based tool used in genetic research, DNA finger printing and in genetic engineering. The technique uses restriction enzymes for the digestion of genomic DNA followed by ligation of adaptors to the sticky ends of restriction fragments (Chial, 2008). AFLP technique can be used to detect various polymorphisms in different genomic regions. AFLP is highly sensitive, has high resolution, reproducible and can amplify between 50-100 fragments at a time (Mueller and Wolfenbarger, 1999). It is useful in detection of polymorphism between closely related genotypes (Kumar *et al.*, 2009). The AFLP primers are generally 17-21 nucleotides in length and anneal perfectly to their target sequences, adapter and restriction sites, and it has small number of nucleotides adjacent to restriction sites (Kumar *et al.*, 2009). AFLP is reliable and robust technique, which is unaffected by small variations in amplification parameters. The technology is advantageous in developing high marker density (Kumar *et al.*, 2009). AFLP has been used for identification of genetic variation in strains and closely related species of plants, animals, fungi and bacteria; and in the construction of genetic linkage maps for QTL identification (Meudt and Clarke, 2007).

Polymerase chain reaction (PCR) is a scientific technique in molecular biology to amplify a single or few copies of a piece of DNA across several orders of magnitude, generating thousands to millions of copies of a particular DNA sequence. As PCR progresses, the DNA generated is used as a template for replication and sets in motion a chain reaction in which DNA template is amplified (James *et al.*, 2001). Single or few copies of a piece of DNA can be amplified across several orders of magnitude, generating millions of copies of DNA fragments. PCR primers to flanking regions are used to amplify DNA fragments. Fragment length polymorphism is created when PCR products from different individuals vary in length as a result of variation in number of repeat units in SSR markers.

2.5 Genetic Linkage Maps

A genetic linkage map is a representation of relative positions of genes and genetic markers on chromosome of biological species determined on the basis of how often the loci are inherited together. Genetic linkage maps play an important role in various fields of fundamental and applied research; in QTL analysis, marker assisted breeding and in map-based cloning. Linkage maps are based on recombination frequencies; and the distance

between points on a genetic map is a reflection of the recombination frequencies between them (Cheema and Dickson, 2009). The first genetic maps were constructed in fruit fly (*Drosophilla melanogaster*) where genes specifying distinct phenotypes like eye color and wing shape as markers were used (Leccoq *et al.*, 2000). The first DNA marker based genetic linkage maps in plants were in *Brassica* and was based on RFLP markers; this knowledge led to rapid construction of linkage maps in many plant species, and placement of genes that control qualitative traits (Landry *et al.*, 1991). RFLP markers were also used in cassava mapping for a dominant gene conferring resistance to cassava mosaic disease (Fregene *et al.*, 1997; Akano *et al.*, 2002). The application of genetic map is to locate specific genes of interest, controlling traits of economic importance in plants. Genetic map is constructed using pairwise linkage analysis of all possible two loci combinations, then group markers into different linkage groups and estimate multipoint recombination fractions among adjacent loci (Toddy *et al.*, 2000).

Markers represent isozymes, DNA fragments and morphological ones, the distance between adjacent markers are expressed as percentage of recombination between the two loci for multiple crossover events expressed in centiMorgans (cM). Natural mapping populations are heterozygous in nature and are developed through open population (Toddy *et al.*, 2000). The genetic map construction requires development of appropriate mapping population, decision on population size, type of molecular markers for genotyping the population, screening parents for marker polymorphism and identification of polymorphic markers to be used for genotyping the progenies. Linkage analysis is done by calculating linkage recombination frequencies between markers, establishing linkage groups, estimation of map distances and determination of marker order using statistical programs (Semagn *et al.*, 2006). If a set of markers are in the same linkage group it is important to determine their correct order and lastly estimating genetic distances between adjacent markers (Yonghui *et al.*, 2011). The logarithm of odds ratios (LOD) which is the ratio of the probability that two loci are linked with a given recombination value over a probability that the two are unlinked, can be used in establishing linkage groups (Stam, 1993a; Semagn *et al.*, 2006). Marker pairs are considered linked with a recombination LOD value above critical linklod, while those with LOD score below linklod are unlinked. A minimum LOD value of 3 between two markers indicates that linkage is 1000 times more likely than no linkage (Stam 1993a; Semagn *et al.*, 2006).

2.5.1 Cassava Genetic Linkage Maps

Mba *et al.* (2001), studied cassava genome mapping to investigate polymorphism in a range of cassava accessions and wild relatives with different random genomic clones and restriction enzymes. From his study, it was concluded that a combined use of RFLP and RAPDs markers would lead to construction of detailed map of cassava. Cassava genetic linkage map was also developed using F₁ population of two geographic divergent parents (Fregene *et al.*, (1997). The genotype TMS I30572 a female parent, a CMD resistant derived through introgression from *Manihot glazovii* and South American male parent CM 2177-2 CMD susceptible. The first map was developed using 90 F₁ individuals. The F₁ population is suitable for linkage analysis due to presence of unique segregating polymorphisms (heterozygosity) and normal meiosis in either or both parents in mapping polyploid genomes (Williams, 1990).

In related studies, one hundred and fifty-eight RFLP, 30 RAPD, 3 microsatellite, and 4 isozyme single dose markers, donated by the female parent of mapping population, were tested for linkage by MapMaker version 3.0 b computer package (Lander *et al.*, 1987). One hundred and thirty-two RFLP, 30 RAPD, 3 microsatellites, and 3 isozyme loci defined 20 linkage groups spanning at 931.6 cM, with an average marker density of 1 marker every 8 cM. The most densely populated linkage group spanned at 51.2 cM, with 26 markers, while least populated group and the longest one, had 8 markers spanning at 80.6 cM. A wide range of marker density indicated different degrees of saturation of linkage groups with markers. From the first cassava map with 132 RFLP, 30 RAPDs, three SSRs and three iso-enzymes markers using F₁ population (Fregene *et al.*, 1997), additional 36 SSRs, 21 EST-SSRs and 12 resistant gene candidates (RGCs) were incorporated, (Mba *et al.*, 2000; Lopez *et al.*, 2007). SSR markers were employed to increase marker density on the map. Mba *et al.*; (2000) developed 172 SSR markers and characterized to saturate the existing linkage map. SSR markers were used to screen 150 progenies of the mapping population TMS I30572 × CM 2177-2. Thirty six markers placed on the map, were evenly distributed over linkage groups. In other studies, 80 RAPD markers, 239 RFLP markers and six EST's were also mapped (Fregene *et al.*, 2001).

Resistant genes to cassava mosaic disease (CMD) in African cassava germplasm were mapped to improve disease resistance in cassava gene pool, in Africa, Latin America and

Asia (Akano *et al.*, 1998). Linkage maps were also used to identify and map rice landraces associated with yield under different nitrogen levels (Srividya *et al.*, 2010). Cassava genetic linkage map was also developed at CIAT and had five known genes including *CMD1* and *CMD2* resistant genes and were placed on the map and a number of quantitative trait loci (QTL) associated with some linkage groups identified (Fregene *et al.*, 2001; Akano *et al.*, 2002).

The second cassava genetic linkage map based on SSR markers was developed and contained 100 markers generated by F₂ population (Okogbenin *et al.*, 2006). Latest cassava genetic linkage map has 510 SSR markers and EST-SSR markers comprising 1,420.3 cM, distributed on 23 linkage groups with a mean distance between markers of 4.54 cM (Sraphet *et al.*, 2011). Genetic mapping populations in cassava were derived from crosses between heterozygous parents F₁ cross (Fregene *et al.*, 1997; Mba *et al.*, 2001; Kunkeaw *et al.*, 2010b). Cassava map was also generated using F₁ population (Kunkeaw *et al.*, 2010) and generated cassava genetic linkage map generated consisted of 231 AFLP markers, 48 sequence-related amplified polymorphism (SRAP) markers, 41 SSR markers and 35 EST-SSR markers. In addition, linkage map was also constructed using EST markers and more than 7,000 SSR loci were identified in the Genbank EST database www.ncbi.nlm.nih.gov/nucest/. (Kunkeaw *et al.*, 2010b). In another study, 425 primer pairs were screened for polymorphism between the parental lines; 81 primer pairs were informative and 56 EST-SSR loci were mapped in F₁ population derived from a cross between Huay Bong 60 by Hanatee (Kunkeaw *et al.*, 2010b). On the same mapping population, 168 informative primer pairs were identified and used in genetic linkage map analysis. In wheat, genetic linkage map using SNP markers has been generated successfully (Bernado *et al.*, 2009; Allen *et al.*, 2011).

2.6 KBioscience Competitive Allele-Specific PCR (KASPar) Technology

KBioscience (Competitive Allele-Specific PCR) genotyping System (KASPar) is a homogeneous fluorescent, end point-genotyping technology. It offers simplest, cost effective and flexible way to determine both SNP and insertion/deletion genotypes KASP assays function well with 3-10ng/ μ in determining high quality DNA per reaction. Genome size is important and reflects the DNA mass required per reaction, greater mass of DNA is required if larger part of the genome is genotyped. (Robinson, and Holme, 2011). KASP

can be used with various sources of DNA; genomic DNA, mitochondrial DNA and Bacterial (haploid) DNA, nested PCR amplicons and the whole genome amplified (WGA) DNA by Phi29 (replicative polymerase from *Bacillus subtilis* phage phi29)(Robinson and Holme, 2011). The source of phi29 is the *E coli* strain that carries the phi29 DNA polymerase gene from bacterial phage phi29; it has exceptional strand displacement and processive synthesis properties. Also DNA can be amplified by degenerate oligonucleotide primer (DoP)-PCR based method. DNA samples can be arrayed in 96, 384 or 1536-well plates and the recommended amount of DNA is: 5µl for 96-well plate, 2.5µl (1-40ng/µl for 384 and 1536-well plates. The minimum amount of samples for KASP genotyping to ensure sufficient genotypes to be able to show clustering is 24. Any combination of SNP and sample numbers can be genotyped by KASPar assay at KBioscience. This is approach is unique to assay miniaturization and 1536 PCR format enables unrivalled flexibility and generation of data sets from one SNP over as few as 20 samples to thousands samples (Robinson and Holme, 2011).

2.7 References

- Achidi, A.U., Ajayi, O.A., Bokanga, M. and Maziya-Dixon, B. 2005. The use of cassava leaves as food in Africa. *Ecology of food and nutrition*, 44:423-435.
- Akano, A., Dixon, A., Mba, C., Barrera, E and Fregene, M. 2002. Genetic mapping of a dominant gene conferring resistance to cassava mosaic disease. *Theor. Appl. Sci.*, 105:521-525.
- Akinpelu, A.O.,L.E.F., Amangbo, L.E.F., Olojede, A.O., Oyekale, A.S. 2011. Health implications of cassava production and consumption. *Journal of agriculture and social research*, 11.
- Alleman, J., Laurie, S.M., Thiart, S., Vorster, H.J. 2004. Sustainable production of root and tuber crops (potato, sweet potato, indigenous potato, cassava) in South Africa. *South Africann Journal* 70:60-66.
- Allen, A.M., Barker, G.L.A., Berry, S.T., Jane, A., Coghill, J.A., Gwillian, R.S., Kirby, S., Robinson, P., Brenchley, R.C., Amore, R.D., McKenzie, N., Waite, D., Hall, A., Beran, M., Hall, N and Edwards, K.J. 2011. Transcript-specific, single-nucleotide polymorphysim discovery and linkage analysis in hexaploid bread wheat (*Triticum aestivum* L.) *Plant Biotechnology Journal*:1-14.
- Appleby, N., Edwards, D., Batley, J. 2009. New technologies for ultra-high throughput genotyping in plants. In: Gustafson J.P., Langridge P., Somers D.J, (eds). *Plant Genomics. Humana Press*: 19-39.
- Ayeh, K.O. 2008. Expressed sequence tags (ESTs) and single nucleotide polymorphisms (SNPs): Emerging molecular marker tools for improving agronomic traits in plant biotechnology. *African Journal of Biotechnology*, 7:331-3401.
- Bardakci, F. 2000. Random amplified polymorphic DNA (RAPD) markers. *Turk Journal Biology*, 25:185-196.
- Bernado, A.N., Bradbury, P.J., Ma, H., Hu, S., Bowden, R.H., Buckler, E.S and Bia, G. 2009. Discovery and mapping single feature polymorphisms in wheat using affymetrix arrays.*BMC Genomics*, 10:251.
- Blair, M.W., Fregene, M.A., Beebe, S.E. and Ceballos, H. 2006.Marker-assisted selection in common beans and cassava.
- Botstein, D., White, R.L., Skolnick, M and Davis, R.W. 1980. Construction of a genetic linkage map in man using restriction fragment length polymorphisms. *The American Journal of Human Genetics*: 314-331.
- Boyko, A. and Kovalchuk, I. 2010. Analysis of mutation/ rearrangement frequencies and methylation patterns at a given DNA locus using restriction fragment length polymorphism. *Pub Med*, 631:49-62.
- Bua, B. and Namara, J. 2009. Reaction of *Nicotiana species* to cassava brown streak virus from Uganda. African Crop science conference proceedings 9:647-650.*African Crop Science Society*.
- Calvert, L.A. and Thresh, J.M. 2002. Virus and virus diseases of cassava: in Cassava Biology and utilization/ edited by Hillocks, R.J., Thresh, J.M and Belloti, A. CABI Publishing 237-260.
- Chial, H. 2008. DNA fingerprinting using amplified fragment length polymorphism (AFLP): No genome sequence required. *Nature Education*, 1.
- Collard, B.C.Y., Mackill, D.J. 2008. Marker assisted selection: an approach for precision plant breeding in the twenty-first century. *Philos Trans R Soc Lond Ser B. Biol. Sci*, 363:557-572

- Collard, B.Y.C., Jahufer, M.Z.Z., Brouwer, J.B., and Pang, E.C.K. 2005. An introduction to markers, quantitative trait loci (QTL) mapping and marker assisted selection for crop improvement. *Euphytica*.142:169–196.
- Ekanayake, I.J., Osiru, D.S.O., Porto, M.C.M. 1997. Morphology of cassava. IITA research guide 61. Training Program; IITA, Ibadan, Nigeria.
- Elias, M., Panaud, O., Robert, T. 2000. Assessment of genetic variability in a traditional cassava (*Manihot esculenta* Crantz) farming system, using AFLP markers. *Pub. Med.* 3:219-230.
- FAO. 2003. Crop Production data 2002, Food and Agricultural Organization of the United Nations, Rome, Italy.
- FAO. 2003. Molecular marker-assisted selection as a potential tool for genetic improvement of crops, forest trees, livestock and fish in developing countries. Electronic forum on biotechnology in food and agriculture. Conference, 10.
- FAO. 2007. Impact of cassava production on the environment.
- Feng, G., Yifu, G., Pinbo, Z. 2000. Production and development of virus-free Sweet potato in China. *Crop production*, 19:105-111.
- Fregene, M., Angel, F., Gomez, R., Rodriguez, F., Chavarriaga, P., Roca, W., Tohme, J. 1997. A molecular genetic map of cassava (*Manihot esculenta* Crantz). *Genetics journal*, 95:431-441.
- Fregene, M., Okogbenin, E., Mba, C., Angel, F., Maria, Christina, Suarez, Guitierrez, Janneth, Chavarriaga, P, Roca, W, Bonierbale, M and Tohme, J. 2001. Genome mapping in cassava improvement: Challenges, achievements and opportunities. *Euphytica*, 120:159-165.
- Fregene, M.A., Suarez. M., Mkumbira, J., Kulembeka, H., Ndedya, E., Kulaya, A., Mitchel, S., Gullberg, U., Rosling, H., Dixon, A.G., Dean, R., Kresovich, S. 2003. Simple sequence repeat marker diversity in cassava landraces: genetic diversity and differentiation in an asexually propagated crop. *Theor. Appl. Genet*, 107:1083-1093.
- Fulton, T.M., Van der Heeven, R., Eannetta, N.T and Tanksley, S.D. 2002. Identification, analysis and utilization of conserved ortholog set of markers for comparative genomics in higher plants. *Plant cell*, 14:1457-1467.
- Ghislain, M., Spooner, D.M., Rodríguez, F., Villamón, F., Núñez, J., Vásquez, C., Waugh, R., Bonierbale, M. 2004. Selection of highly informative and user-friendly microsatellites (SSRs) for genotyping of cultivated potato. *Theor. Appl. Genet*, 108:881-890.
- Hahn, S.K., Terry, E.R., Leuschner, E.K., Akobundu, I.O., Okali, C., La, R. 1989. Cassava improvement in Africa. *Field Crop Res.*2.
- He, X., Chen, T and Zhu, J. 2011. Regulation and function of DNA methylation in plants and animals. *Cell Research*, 21:442-465.
- Hillocks, R. and Jennings, D.L. 2003. Cassava brown streak disease: a review of present knowledge and research needs. *International Journal of Pest Management*, 49: 225-234.
- Holland, J. 2004. Implementation of molecular markers for quantitative traits in breeding programs-challenges and opportunities. “New directions for a diverse planet”. Proceedings for the 4th International Crop Science Congress. Regional Institute, Brisbane, Australia.
- Jaemin, C., Cainui, L., Russell, J., Koheland., John, Z.Y.U. 2011. Breeding and genetics. Development and mapping of gene-tagged SNP markers for gland morphogenesis in cotton. *The Journal of Cotton Science*, 15:22-32.

- James, M.N., David, R.W., Brian, G.R., John, N.A., Wayne, A.P., and Reger, H.B. 2001. A retrospective DNA marker assessment of the development of insect resistance in Soybean. *Crop Sci. Journal*, 41:1931–1939.
- Katinila, N.A., Hamza, H and Raya, M.D. 2003. Social impact of cassava brown streak virus disease on rural livelihoods in southern Tanzania. In *Cassava Brown Streak Virus Disease: Past, Present, and Future*, ed. Legg, J.P. and Hillocks, R.J. Aylesford, U.K.: Natural Resources International Limited. Proceedings of an International Workshop, Mombasa, Kenya.
- Knapp, S. 1998. Marker-assisted selection as a strategy for increasing the probability of selecting superior genotypes. *Crop Sci*, 38:1164–1174
- Korzun, V. 2003. Molecular markers and their applications in cereals breeding.
- Kumar, P., Gupta, V.K., Misra, A.K., Modi, D.R and Pandey, B.K. 2009. Potential molecular markers in plant biotechnology. *Plant Omics Journal*, 2:141-162.
- Kunkeaw, S., Yoocha, T., Sraphet, S., Boonchanawiwat, A., Boonseng, O., Lightfoot, D.A., Triwitayakorn, K and Tangphatsornruang, S. 2010. Constructing genetic linkage map using SSR markers from EST markers for cassava. *Molecular Breeding Springer*, 27:67-75.
- Lan, T., DelMonte, T.A., Reischmann, K.P., Hyman, J., Kowalski, S.P., McFerson, J., Kresovich, S. and Paterson, A.H. 2000. An EST-enriched comparative map of *Brassica oleracea* and *Arabidopsis thaliana*. *Genome Research*, 10:776-788.
- Landry, B.S., Hubert, N., Etoh, T., Harada, J.J., Lincoln, S.E. 1991. A genetic map of *Brassica napus* based on restriction fragment length polymorphism detected with DNA sequences. *Genome*, 34:543-552.
- Lebot, V. 2009. Tropical Root and Tuber Crops. Cassava, Sweet Potato, Yams and Aroids. pp74.
- Lecoq, H., Desbiez, C., Delécolle, B., Cohen, S., Mansour, A. 2000. Cytological and molecular evidence that the whitefly-transmitted cucumber vein yellowing virus is a tentative member of the family *Potyviridae*. *Journal of General Virology*, 81:2289-2293.
- Lopez ,C.E., Quesada-Ocampo, L.M., Bohorquez, A., Duque, M.C., Vargas, J., Tohme, J., Verdier, V. 2007. Mapping EST derived SSRs and ESTs involved in resistance to bacterial blight in *Manihot esculenta*. *Genome*, 50:1078–1088
- López, C., Piegu, B., Cooke, R., Delseny, M., Tohme, J. and Verdier, V. 2005. Using cDNA and genomic sequences as tools to develop SNP strategies in cassava (*Manihot esculenta* Crantz). *Theor. Appl. Genet.* 110:425-431.
- Mba, P.E.C., Stephenson, P., Edward, K., Melzer, S., Nkumbira, J., Gulberg, U., Apel, K.T. and Fregene. 2000. Simple Sequence Repeats (SSR) Markers Survey of the Cassava (*Manihot esculenta* Crantz) Genome: Towards an SSR- based molecular genetic map of Cassava .<http://ciat-library.ciat.cgiar.org/Articulos-cassava.pdf>
- Mbanzibwa, D.R., Tian, Y., Mukasa, S.B. and Valkaen, J.P.T. 2009. Cassava brown streak virus (*Potyviridae*). Encodes a putative Maf/HAM1 proteinase that suppresses RNA silencing but contains no HC-Pro. *Journal of Virology*, 83:6934-6940.
- Meudt, H.M and Clarke., A.C. 2007. Almost forgotten or latest practice? AFLP applications analyses and advances. *Trends Plant Sci.* 12:106-117.
- Mihaljevic, R., Schon, C., Friedrich, U and Melchinger. 2005. Correlations and QTL Correspondence between line per se and testcross performance for agronomic traits in four populations of European Maize. *Crop Science Journal*, 45:114-122.
- Mittal, N and Dubey, A.K. 2009. Microsatellite markers a new practice of DNA-based markers in molecular genetics. *Pharmacognosy Review Article*, 3:235-246.

- Monger, W.A., Seal, S., Cotton, S., Foster, G.D. 2001. Identification of different isolates of cassava brown streak virus and development of a diagnostic test. *Plant Pathology Journal*, 50:768-775.
- Monger, W.A., Seal, S., Isaac, A.M and Foster, G.D. 2001a. Molecular characterization of the cassava brown streak virus coat protein. *Plant Pathology*,50:527–534.
- Moose, S.P and Mumm, R.H. 2008. Molecular plant breeding as the foundation for 21st Century crop improvement. *Plant Physiology*, 147:3967-977.
- Mueller, U.G., Wolfenbarger, L.L., October. 1999."AFLP genotyping and fingerprinting". *Trends Ecol. Evol. (Amst)*, 14:389–394.
- Muhanna, M and Mtunda, K. 2002. Report on a survey of cassava disease in Tanzania. Ministry of Agriculture and Food Security, Tanzania.
- Nichols, R.F.J. 1950. The brown streak disease of cassava: distribution, climatic effect and diagnostic symptoms. *East African Agricultural Journal*, 15:154-160.
- Okogbenin, E., Marin, J. and Fregene, M. 2006. An SSR-Based molecular genetic map in cassava. *Euphytica*, 147:433-440.
- Olsen, K.M and Schaal, B.A. 1999. Evidence on the origin of cassava: Phylogeography of *Manihot esculenta*.. Proceedings of the National Academy of Sciences, 96: 5586-5591
- Palumbo, J.C., Horowitz, A.R., Prabhaker, N. 2001.Insecticidal control and resistance management of *Bemisia tabaci*. *Crop protection Journal*,20:739-765.
- Peleman, J. and Van Der Voot, R. J. 2003. Breeding by design. Trends in plant science, 8: 330-334. Dellaporta, S.L., Wood J., Hicks J.R. 1983. A plant DNA mini-preparation: version II. *Plant Molecular Biology Report*, 1:19-21.
- Rafalsk, A.2002. Applications of single nucleotide polymorphisms in crop genetics. *Current Opinion in Plant Biology*, 5:94-100.
- Raji, A.A.J., Fawole, I., Gedil, M., Dixon, A.G.O. 2009.Genetic differentiation analysis of African cassava (*Manihot esculenta*) landraces and elite germplasm using amplified fragment length polymorphism and simple sequence repeat markers. *Annals Applied Biol*,155:187-199.
- Raprey, R., Harbron, S. (Eds). 2004. Molecular analysis and genome discovery. Chichester, John, Wiley and Sons, Ltd.
- Ribaut, J.M., Ragot, M. 2007. Marker-assisted selection to improve drought adaptation in maize: the backcross approach, perspectives, limitations, and alternative. *J. Exp. Bot*, 58:351–360
- Roa, A.C., Chavarriaga-Aguirre, P., Duque, M.C., Maya, M.M., Bonierbale, M.W., Iglesias, C., Tohme, J.2000.Cross-species amplification of cassava (*Manihot esculenta*) (Euphorbiaceae) microsatellites: allelic polymorphism and degree of relationship. *American Journal of Botany*, 87:1647-1655. Published by Botanical Society of America.
- Roa, A.C., Maya, M.M., Duque, M.C., Tohme, J., Allem, A.C. and Bonierbale, M.W. 1997. AFLP analysis of relationships among cassava and other *Manihot species*. *Springer-Verlag*, 95:741-750.
- Robinson, P. and Holme, J. 2011. KASP version 4.0, SNP Genotyping Manual.1.001. http://www.cerealsdb.uk.net/CerealsDB/Documents/PDFs/KASP_SNP_Genotyping_Manual.pdf. 6th Nov. 2012.
- Rosyara, U.R. 2006. Requirement of robust molecular marker technology for plant breeding applications. *Journal of Plant Science group*1:67-72.
- Rosyara, U.R. and Joshi, B.K, 2008. Association mapping for improvement of quantitative traits in plant breeding populations. Third SAS-N convention“ Agricultural research for enhancing livelihood of Nepalese People”. *Society of Agricultural Scientists, Nepal*.

- Semagn, K., Bjornstad, A and Ndjioudjop, M. N. 2006. Principles, requirements and prospects of genetic mapping in plants. *African Journal of Biotechnology*, 5:2569-2587.
- Sraphet, S.A., Boonchanawiwat, T., Thanyasiriwat, O., Boonseng, S., Tabata, S., Sasamoto, K., Shirasawa, S., Isobe, D. A., Lightfoot, S., Tangphatsornruang and Triwitayakorn, K. 2011. SSR and EST-SSR-based genetic linkage map of cassava (*Manihot esculenta* Crantz). *Theor. Appl. Genet.*, 122:1161–1170.
- Srividya, A., Vemireddy, L.R., Hariprasad, A.S., Jayaprada, M and Sridhar, S., Ramanarao, P.V., Anuradha, G and Sidiq, E.A. 2010. Identification and mapping of landrace derived QTL associated with yield and its components in rice under different nitrogen levels and environments. *Int. J. Plant Breed. Genet.*, 4:210-227.
- Stam, P. 1993. Construction of integrated genetic linkage maps by means of a new computer package: JoinMap. *The Plant Journal*, 3:739-744.
- Storey, H.H. and Nichols, R.F.W. 1938. Studies of the mosaic disease of cassava. *Annals of Applied Biology*, 25:790–06.
- Storey, H.H. 1936. Virus Diseases on East African Plants. VI-A Progress Report on studies of diseases of cassava. *East African Agricultural Journal*, 2:34-39.
- Syvanen, A.C. 2001. Assessing genetic variation: genotyping single nucleotide polymorphisms. *Nat. Rev. Genet.*, 2:930-942.
- Thresh, J.M and Cooter, R.J. 2005. Strategies for controlling cassava mosaic disease in Africa. *Plant Pathology*, 54:587-614.
- Thro, A.M., Roca, W.M., Restrepo, J., Caballero, H., Poats, S., Escobar, R., Mafla, G. 1999. Can *in vitro* biology have farm-level impact for small-scale cassava farmers in Latin America? *Environmental Science*, 35:382-387
- Tuberosa, R., Salvi, S., Giuliani, S., Sanguineti, M.C., Belotti, M., Conti, S., Landi, P. 2007. Genome-wide approaches to investigate and improve maize response to drought. *Crop Sci*, 47:S120-S141.
- Van den Botch, F., Jeger, M.J. and Gillian, C.A. 2007. Disease control and its selection for damaging plant virus strains in vegetative propagated staple crops: A theoretical assessment. Proceedings of Royal Society: *Biological Sciences*, 274:11-18.
- Westby, A. 2002. Cassava utilization, storage and small-scale processing. CAB International. Cassava: Biology, production and utilization (eds Hillocks R.J., Thresh J.M and Bellotti, A.C).
- Williams, J.G.K., Kubelik, A.R., Livak, K.J., Rafalski, J.A. and Tingey, S.V. 1990. DNA polymorphisms amplified by arbitrary primers are useful as genetic markers. *Oxford Journal. Nucleic Acid Research*, 39:515

CHAPTER THREE

Determination of Cassava (*Manihot esculenta* Crantz) Hybrids using microsatellite markers

3.1 Abstract

Cassava (*Manihot esculenta* Crantz) brown streak disease (CBSD) is one of the diseases caused by virus that limit cassava production in Eastern Africa. The objective of this experiment was to determine heterozygosity of an F₁ population from a cross between Nachinyaya (CBSD tolerant) and AR37-80 (CBSD susceptible) using DNA markers. The knowledge of molecular markers linked to disease resistance is essential if marker assisted breeding (MAB) is to be applied to control (CBSD). Population integrity was evaluated using SSR markers at Biosciences Eastern and Central Africa (BecA) laboratory, Nairobi. DNA was extracted from leaf samples of 271 genotypes that were collected from Makutupora, Tanzania. The parents were genotyped loci using 26 SSR markers in prism ABI 3730 sequencer. Fourteen polymorphic markers were identified and used to confirm the hybrids. Eleven informative SSR markers confirmed 257 hybrids; however, twelve individuals with missing data and two possible off-types were excluded from further consideration. A total of 257 true hybrids were identified in this experiment and would be used in the construction of genetic linkage map because the minimum population size for genetic linkage mapping is 50 individuals.

3.2 Introduction

Cassava (*Manihot esculenta* Crantz) is about 91.5% outcrossing species; consequently, mapping population must be derived from the divergent parental genotypes to the trait of interest. Highly heterozygous population segregates and they produce heterozygous progeny that contains allele from each parent. Cassava is an out crossing species, in which it is not possible to generate in-bred lines, thus F₁ progeny is therefore suitable for linkage mapping. A population size ranging from 50 to 250 is recommended for mapping as a population of less than 50 individuals provides poor mapping resolution (Kulembeka 2010). However, high resolution mapping requires a population size above 250 individuals and is useful for specific genomic regions and mapping QTLs of minor effect (Semagn, 2010). Messeguer *et al.*, (1991) analyzed over 1000 plants to construct high resolution map around *Mi* gene of tomato (*Lycopersicon esculentum* L.), and identified nematode resistant tomato varieties. Stuber *et al.*, (1987) used above 1800 maize (*Zea mays* L.) individuals from F₂ population and identified

QTLs associated with variation in yield component; 3472 F₂ near isogenic lines (NIL) were used to construct detailed map around fruit weight locus (Alpert and Tanksley, 1996; Young, 2000). In screening the population, SSR markers are used because of their multi-allelism enabling detection of off-types, and abundance throughout plant and animal genomes.

3.3 Materials and Methods

3.3.1 Genotypes

In 2010 and 2011 F₁hybrids were developed from a cross between Nachinyaya (CBSD tolerant) and AR37- 80 (CBSD susceptible). These genotypes were selected as parents because they are genetically quite distantly related as AR37-80 is from South America and Nachinyaya from Tanzania; they are therefore unlikely to share a recent ancestry. This will improve the likelihood of finding polymorphic markers amongst the genotypes which are necessary for developing genetic linkage maps. Nachinyaya is a farmer preferred variety that is widely grown in Tanzania. Its pedigree is not yet known, however, it does have *Manihot glaziovii* characteristics (wild species). This variety has purplish-green apical leaves with pubescence, yellowish-green petiole color and ovoid central leaf. The leaf color is light green and has five leaf lobes with smooth margins; and green veins. The petioles are arranged irregularly and stems have prominent scars. Stem cortex has dark green and light brown epidermis; the exterior part of stem is dark brown. Nachinyaya variety has straight stem and the color of end branches of mature plant is green, it also has short stipules with split or forked margins. The plant has compact shape; four branching levels and dichotomous branching habit. The root peduncle is mixed and has some root constrictions, cylindrical root shape. The external color of storage root is dark brown, white root pulp and pink root cortex; with easy peeling characteristics. The texture of root epidermis is rough and the cyanide potential (CNP) is 2.25 (Kawuki *et al.*, 2011). Genotype AR37-80 flowers profusely and it is recommended for crossing purposes and is highly susceptible to CBSD. The pedigree of AR37-80 = C-33 × CW259-42 (TAI 8 × CW66-73) (MFLA437-7 × CM2766-5). C-33 is a CMD-resistant clones kindly shared by IITA, CW 259-42 is a backcross between MTAI 8 (a commercial clone released in Thailand as Rayong 60) and an interspecific cross between *Manihot flabellifolia* and CM 2766-5 (an elite clone adapted to the acid soils environment and therefore, carrying resistance to CBB and super elongation disease).

3.3.2 Experimental Site

A population of 398 F₁ genotypes was developed by crossing (CBSD tolerant) and AR37-80 (CBSD susceptible) at Sugarcane Research Institute, Kibaha (6°46'S and 38° 59' E) which is 35km East of Dar es Salaam. Seeds were germinated in plastic trays and the plantlets transplanted in a disease-free location at Makutupora (6°10' S and 35°44' E).

3.3.3. Plant Samples

Approximately 0.15-0.2g of young folded leaves were collected from parental genotypes and progenies at Makutupora Dodoma, Tanzania; two months after transplanting. The leaf samples were placed in aluminium foil packets, labeled and immediately placed in polystyrene boxes containing dry ice. From young plant of less than a month after transplanting, one small leaflet was sampled, and placed into a 96-deep well reaction plate which had a steel ball at the base. These tissues were then placed in polystyrene boxes containing dry ice and clearly labeled and stored at -80°C awaiting DNA extraction at eastern and central Africa laboratory, Nairobi.

3.3.4 DNA Extraction

3.3.4.1. Small-scale DNA isolation

Adequate liquid nitrogen was poured into pre-chilled clean pestle and mortar. Approximately 0.15 to 0.2g of frozen leaf tissue was then placed in the mortar and ground to fine powder. The ground sample was transferred into 2ml eppendorf tube using chilled spatula. About 800 µl of 3% Cetyl Trimethyl Ammonium Bromide (CTAB) extraction buffer {(30mM ethylenediaminetetraacetic acid (EDTA), 0.1 M Tris-HCl pH 8.0, 1.2M sodium chloride (NaCl), 3% CTAB, 700µL of 3% β-mercaptoethanol} was added to each chilled sample. In addition, 50µl Sodium deodocyl sulphate (SDS) was then added to the sample. The tubes were then incubated in a water bath maintained at 65°C (Kotterman Labor techniK made in W-Germany) for 15 minutes with gently mixing. The samples were then cooled at room temperature for 2 minutes. Approximately, 250µl of chilled 5M potassium acetate was added into each sample and gently mixed by inverting 5-6 times and incubated on ice for 20 minutes. The samples were then centrifuged at 12,000g in eppendorf centrifuge (Model No.5417C) for 10 minutes and then transferred to new 2ml eppendorf tubes.

DNA pellet was precipitated by adding 1000 µl of chilled isopropanol and gently inverted 8-10 times. The samples were then placed in a freezer at -80°C for 1 hour, and

centrifuged at 12,000g for 10 minutes. Supernatant was decanted and DNA was air dried at room temperature for one hour. Thereafter, pellet was re-suspended in 500 µl of 50mM Tris-HCl/10 mM EDTA and incubated at 65°C for 10-15 minutes with constant gentle shaking. The samples were then transferred to 1.5 µl eppendorf tubes, and to each sample, 500 µl chilled iso-propanol was added, and then mixed by inverting 8-10 times. Samples were then incubated at -80°C for 1 hour and centrifuged at 12,000g for 10 minutes. Supernatant was decanted and genomic DNA pellet was air dried at room temperatures for another one hour. Two hundred microliters of 10mM Tris-HCl/1 mM EDTA, containing 100µg/ml RNaseA, was added to the pellet. To extract the solvent, 200µl phenol: chloroform: isoamylalcohol (25:24:1) was added to each sample and mixed by inverting twice, and centrifuged at 12,000g for 10 minutes. A fixed volume of 180µl transferred to a fresh eppendorf tube and then added with chloroform: isoamylalcohol (24:1) to each sample and then gently mixed. Samples were centrifuged at 12,000g for 10 min and a fixed volume of 180µL aqueous layer was transferred to a fresh eppendorf tube.

To purify the DNA 315µl ethanol: sodium acetate solution was added to each sample and placed in -20°C for five minutes then centrifuged at 12,000g for five minutes. The supernatant was decanted from each sample and the pellet washed with 200µl 70% ethanol, centrifuged at 12,000g for five minutes. The supernatant was decanted from each sample, the pellet air-dried at room temperature for 1 hour, then dissolved in 100µl low-salt 1XTE buffer and stored at 4°C.

3.3.4.2 High-throughput DNA Extraction Using a Genogrinder

For those hybrid samples collected on a Genogrinder plate; samples were ground using a genogrinder (Geno/Grinder 2000. Spex Corti Prep) and extracted in a 96 well format using the modified method described by Dellaporta (1983).

3.3.4.3 DNA Quantification

The quantity and quality of DNA from each sample was determined using NanoDrop 1000 Spectrophotometer at 260/230 and 260/280nm. The spectrophotometer was calibrated using 1.4 µl blank sample of low salt TE buffer. After calibration, quantification was done by loading 1.4µl of each sample from parental and F₁ hybrids on pedestal of automated NanoDrop spectrophotometer.

Electrophoresis was also carried out on 1% Agarose gel stained with 4µl of GelRed in 1X Tris boric EDTA (TBE) tank buffer at 110V for 30 minutes. Approximately, 3µl of

loading dye was added to 3µl genomic DNA then loaded into the wells of the gel. Lambda DNA ladder was loaded at the end wells and electrophoresis was done at 110V for 30 minutes. The quality of DNA was visually determined by observing gel under ultraviolet light (UV). The stock DNA samples were then stored at -20°C.

3.3.4.4 Dilution of stock DNA and storage

All the DNA from each sample for PCR amplification were diluted to achieve a concentration of 50ng/µl by adding ddH₂O basing on the concentrations of stock DNA quantified using NanoDrop. The quantity of DNA drawn was based on concentration of each sample and raised to final working volume of 100µl. DNA samples for SNP genotyping were diluted to 25ng/µl. The remaining stock DNA was stored in -20°C for future use.

3.5 Selection of polymorphic SSR markers for screening F₁ genotypes

26 SSR markers were screened for polymorphism with the two parents of the mapping population, AR37-80 and Nachinyaya (Table 1). These markers were the available markers at the Laboratory. Polymorphic markers were used to detect true hybrid genotypes.

3.5.1 DNA Amplification.

For polymorphism and genotyping tests, the master-mix was prepared for PCR reaction which consisted 0.075µl *Taq* polymerase (5U/µl), 1.0µl 10x PCR Buffer, 0.8µl MgCl₂ (50 mM), 0.8µl of each primer (F/R) (1pmoles/µl), 0.8µl dNTP (2.5mM of each dNTP), 4.725µl Milli-Q H₂O and 1.0µl DNA (50ng) for one reaction and final reaction volume of 10µl. The PCR reaction was performed in a GeneAmp PCR System (9700 Applied Biosystems) for 30 cycles. The thermocycling profile was as follows: 95°C for 3 min, 95°C for 30 seconds, 57°C for 1 min, (optimal annealing temperature for primers); 72 °C for 1 min, 72 °C for 30 min, (final extension). The amplification products were determined by electrophoresis on 2% agarose gel. 1 µl of two to four pooled PCR products were mixed with 9µl formamide–standard mix (20µL GS500 LIZ and 900µL HI-DI Formamide Applied Bioscience) was denatured at 95°C for three minutes and then sequenced on Amplified Biosystem’s (ABI) 3730 DNA analyzer. The allele sizes and genotypes were scored using GeneMapper Version 4.0 software.

3.6 Results

3.6.1 Selection of polymorphic SSR markers

Eleven polymorphic and informative markers were identified and used for screening hybrids were SSRY12, SSRY5, SSRY63, SSRY171, SSRY51, SSRY52, NS911, SSRY151, SSRY19, SSRY38 and SSRY169 (Table1 and Table 2). Fifteen markers were either non - informative or failed to amplify the parental DNA samples. The size of these polymorphic markers ranged from 89-303bp with annealing temperatures ranging between 45-55°C. According to ABI3730 prism analyzer system used for genotyping the allele size, height, peak and genotype quality (GQ) were used to determine polymorphic SSR markers (Table 2). In this study, 14 cassava SSR markers were identified as polymorphic while 5 markers were monomorphic. Two SSR markers amplified DNA from the male parent AR37-80 only and four markers failed to amplify both parents. The allele size 2 was more than allele size 1. In contrast, the higher values were observed for height 1 and peak area 1 than height 2 and peak area 2, respectively. All the monomorphic markers exhibited same allele sizes (Allele1 and 2). Similarly the height and peaks for monomorphic markers were the same. The two parents, Nachinyaya and AR37-80 exhibited good quality (GQ) because it ranged from 0.3945 to 1.0000 as poor quality genotype has a 0.0000 to 0.2500.

SSR markers used to detect hybrids depicted in Table 3, the homozygote male parent could not be detected while heterozygotes and homozygote female parent (AR37-80) were detected. Out of eleven SSR markers used to ascertain hybrids, NS911 and SSRY63 amplified 51.8-64.6% homozygous loci. SSRY151, SSRY171, SSRY51 and SSRY19 discriminated 50 to 86.4% heterozygotes of the hybrids tested (Table 3). However, the same ratios of 50:50 between homozygote and heterozygote loci were notably observed on SSRY 169, SSRY38, SSRY19, SSRY5 and SSRY63. Nevertheless, SSR171 and SSRY51 amplified more heterozygous loci than the rest of the markers.

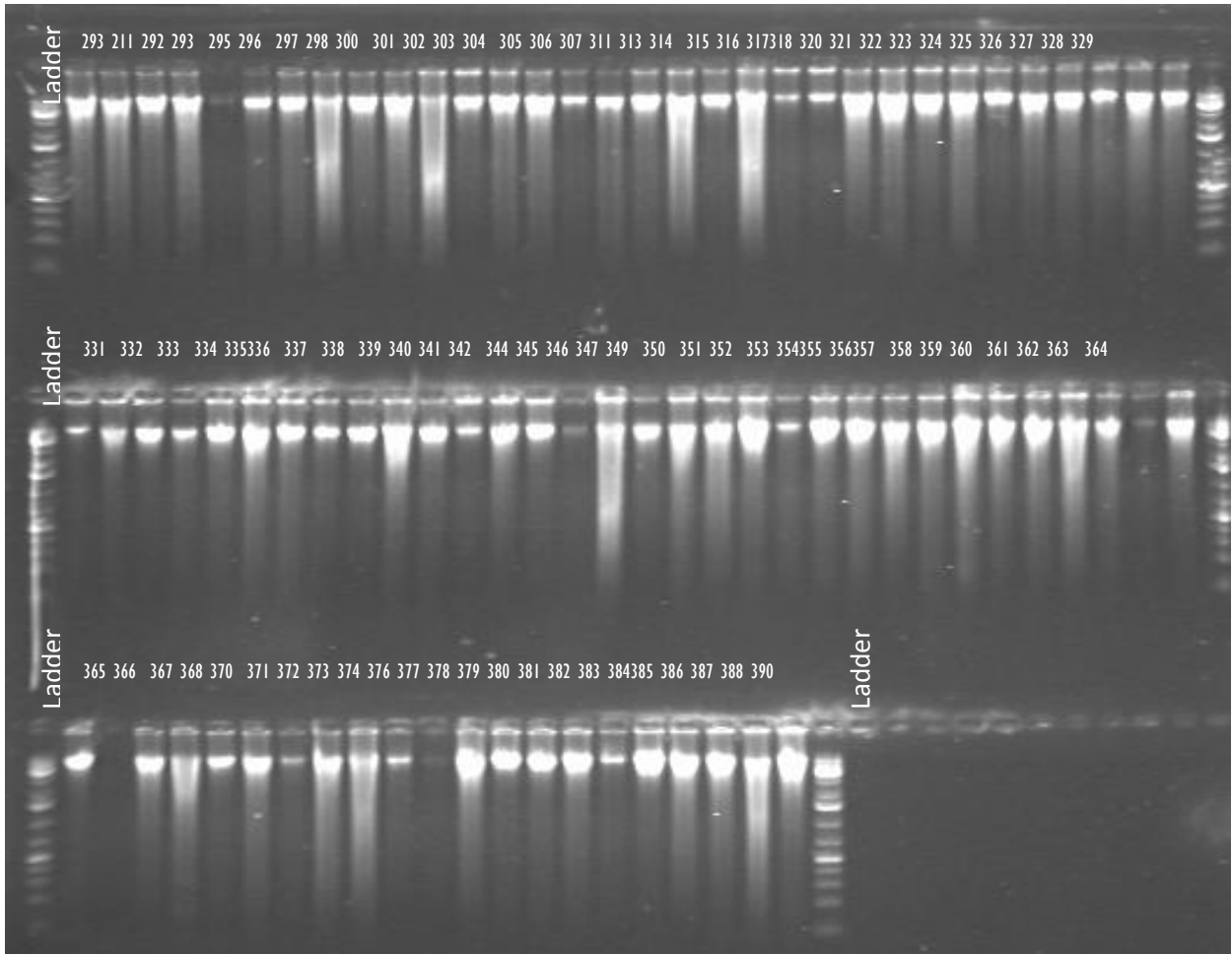

Plate 1: DNA profile of some genomic DNA bands that were stained with GelRed for 30 minutes after electrophoresis from cassava F₁ hybrids developed from Nachinyaya × AR37-80. The numbers in the gel picture identifies the progeny.

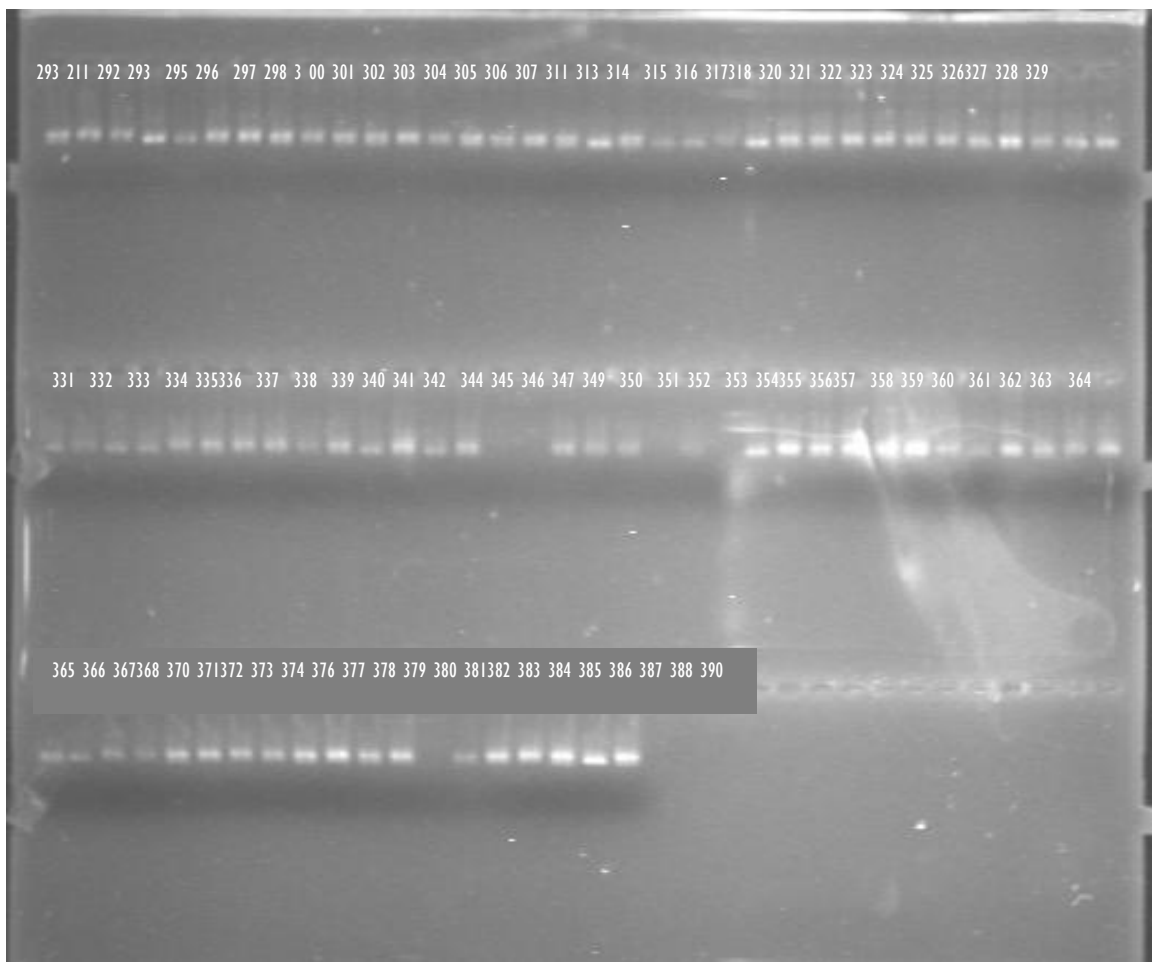

Plate 2: Amplified DNA fragments with SSRY 151 marker from 87 Cassava hybrids derived from Nachinyaya × AR37- 80

Table 1: list of twenty six cassava SSR Markers screened for Polymorphism for variety Nachinyaya and line AR37-80.

Maker name	Type of repeat motif	Primers sequence	Annealing Temp (°C)	Size (bp)	
SSRY5	GA (38)	Forward 5'-3'	TGATGAAATTCAAAGCACCA	55	173
		Reverse 5'-3'	CGCTACCACTGCCATAAAC		
SSRY9	GT (15)	Forward 5'-3'	ACAATTCATCATGAGTCATCAACT	55	278
		Reverse 5'-3'	CCGTTATTGTTTCCTGGTCCT		
SSRY12	CA (19)	Forward 5'-3'	AACTGTCAAACCATTCTACTTGC	55	266
		Reverse 5'-3'	GCCAGCAAGGTTTGCTACAT		
SSRY19	CT (8) CA (18)	Forward 5'-3'	TGTAAGGCATTCCAAGAATTATCA	55	214
		Reverse 5'-3'	TCTCCTGTGAAAAGTGCATGA		
SSRY21	GA (26)	Forward 5'-3'	CCTGCCACAATATTGAAATGG	55	192
		Reverse 5'-3'	CAACAATTGGACTAAGCAGCA		
SSRY38	CA (17)	Forward 5'-3'	GGCTGTTCGTGATCCTTATTAAC	55	122
		Reverse 5'-3'	GTAGTTGAGAAAACCTTGCATGAG		
SSRY51	CT (11) CG CT (11) CA (18)	Forward 5'-3'	AGGTTGGATGCTTGAAGGAA	55	298
		Reverse 5'-3'	GGATGCAGGAGTGCTCAACT		
SSRY59	CA (20)	Forward 5'-3'	GCAATGCAGTGAACCATCTTT	55	158
		Reverse 5'-3'	CGTTTGTCCCTTCTGATGTTT		
SSRY63	GA (16)	Forward 5'-3'	TCAGAATCATCTACCTTGGCA	55	290
		Reverse 5'-3'	AAGACAATCATTTTGTGCTCCA		
SSRY52	GT (19)	Forward 5'-3'	GCCAGCAAGGTTTGCTACAT	55	266
		Reverse 5'-3'	AACTGTCAAACCATTCTACTTGC		
SSRY64	CT (13) CG CT (6)	Forward 5'-3'	CGACAAGTCGTATATGTAGTATTCAC	55	194
		Reverse 5'-3'	GCAGAGGTGGCTAACGAGAC		
SSRY69	CT (18) ATT AT (2) CTTTCTT CTTT (2) CCTTCT	Forward 5'-3'	CGATCTCAGTCGATACCCAAG	55	239
		Reverse 5'-3'	CACTCCGTTGCAGGCATTA		
SSRY100	CT (17) TT CT (7) CCCT	Forward 5'-3'	ATCCTTGCCCTGACATTTTGC	55	210
		Reverse 5'-3'	TTCGCAGAGTCCAATTGTTG		
SSRY102	GT (11)	Forward 5'-3'	TTGGCTGCTTTCACTAATGC	55	179
		Reverse 5'-3'	TTGAACACGTTGAACAACCA		
SSRY110	GT (12)	Forward 5'-3'	TTGAGTGGTGAATGCGAAAG	55	247
		Reverse 5'-3'	AGTGCCACCTTAAAAGAGCA		
SSRY135	CT (16)	Forward 5'-3'	CCAGAACTGAAATGCATCG	45	253
		Reverse 5'-3'	AACATGTGCGACAGTGATTG		

Table1.Continued

Maker name	Type of repeat motifs	Forward and reverse Primers sequence	Annealing Temp (°C)	Size (bp)
SSRY147	-	Forward 5'-3' GTACATCACCACCAACGGGC Reverse 5'-3' AGAGCGGTGGGGCGAAGAGC	45	113
SSRY148	-	Forward 5'-3' GGCTTCATCATGGAAAAACC Reverse 5'-3' CAATGCTTTACGGAAGAGCC	45	114
SSRY151	-	Forward 5'-3' AGTGGAAATAAGCCATGTGATG Reverse 5'-3' CCCATAATTGATGCCAGGTT	45	182
SSRY155	-	Forward 5'-3' CGTTGATAAAGTGGAAAGAGCA Reverse 5'-3' ACTCCACTCCCGATGCTCGC	55	158
SSRY181	GA (22) G (3) CGA (3) GGAAGA (4)	Forward 5'-3' GGTAGATCTGGATCGAGGAGG Reverse 5'-3' CAATCGAAACCGACGATACA	55	199
SSRY182	CA (17) N (31) GAGG GA (8)	Forward 5'-3' GGAATTCTTTGCTTATGATGCC Reverse 5'-3' TTCCTTTACAATTCTGGACGC	55	253
NS911	-	Forward 5'-3' TGTGTTCAGACGATGTCCAA Reverse 5'-3' TTGAAGCAGTTATGAACCGT	50	127
SSRY161	CT (11) TT CT (21) CA (19)	Forward 5'-3' AAGGAACACCTCTCCTAGAATCA Reverse 5'-3' CCAGCTGTATGTTGAGTGAGC	55	220
SSRY169	GA (19) A (3) GAA (2)	Forward 5'-3' ACAGCTCTAAAAACTGCAGCC Reverse 5'-3' AACGTAGGCCCTAACTAACCC	55	100
SSRY171	TA (5) CATAGATA (8) GC GA (23) GTGA (2)	Forward 5'-3' ACTGTGCCAAAATAGCCAAAATAGT Reverse 5'-3' TCATGAGTGTGGGATGTTTTTATG	55	291

Table 2: Polymorphic Screening of SSR markers Against Cassava Parental genotypes (Nachinyaya and AR37-80)

Genotype	Marker	Allele 1	Allele 2	Size 1	Size 2	Height 1	Height 2	Peak Area 1	Peak Area 2	GQ	Polymorphism
AR37-80	NS911	113	123	112.57	122.02	31513	16891	210837	110293	1.0000	Polymorphic
Nachinyaya	NS911	123	123	123.04	123.04	26893	26893	173630	173630	0.7889	Polymorphic
AR37-80	SSRY100	212	217	211.81	217.56	4508	854	27951	5392	1.0000	Polymorphic
Nachinyaya	SSRY100	217	219	217.47	219.47	2836	1915	16779	11512	0.7889	Polymorphic
AR37-80	SSRY102	179	179	178.88	178.88	16015	16015	97410	97410	0.7889	Monomorphic
Nachinyaya	SSRY102	179	179	178.80	178.80	14829	14829	89350	89350	0.7889	Monomorphic
AR37-80	SSRY110	248	248	247.73	247.73	26323	26323	175041	175041	0.7889	Monomorphic
Nachinyaya	SSRY110	248	248	247.71	247.71	15650	15650	106621	106621	0.7889	Monomorphic
AR37-80	SSRY12	265	265	265.15	265.15	18597	18597	113595	113595	0.7889	Polymorphic
Nachinyaya	SSRY12	254	261	254.46	260.97	12270	7373	76382	45810	0.7889	Polymorphic
AR37-80	SSRY135	235	254	234.57	254.05	9306	4065	56100	25124	0.3945	Polymorphic
Nachinyaya	SSRY135	237	246	236.55	246.24	6650	4373	38764	26246	0.7889	Polymorphic
AR37-80	SSRY147	111	115	111.22	115.41	11356	6621	66424	36693	0.7889	Polymorphic
AR37-80	SSRY148	112	118	112.40	118.48	3101	2713	19533	16021	0.7889	Polymorphic
Nachinyaya	SSRY148	110	112	110.43	112.40	2997	2092	18446	11389	0.7889	Polymorphic
AR37-80	SSRY151	188	210	187.54	210.29	3913	4091	24663	26242	0.7889	Polymorphic
Nachinyaya	SSRY151	180	185	179.66	185.48	873	700	5573	4452	0.7889	Polymorphic
AR37-80	SSRY155	157	157	157.01	157.01	2486	2486	14238	14238	0.7889	Monomorphic
Nachinyaya	SSRY155	157	157	156.95	156.95	14319	14319	81080	81080	0.7889	Monomorphic
AR37-80	SSRY161	221	221	220.94	220.94	7217	7217	42007	42007	0.7889	Polymorphic
Nachinyaya	SSRY161	177	215	176.86	214.77	17555	6452	103855	37177	0.3945	Polymorphic
AR37-80	SSRY169	89	99	89.11	99.28	13579	8922	76125	51847	0.7889	Polymorphic
Nachinyaya	SSRY169	99	99	99.19	99.19	15516	15516	90371	90371	0.7889	Polymorphic
AR37-80	SSRY171	289	303	288.79	302.74	4502	2001	26996	12015	0.3945	Polymorphic
Nachinyaya	SSRY171	289	289	288.75	288.75	4976	4976	30496	30496	0.7889	Polymorphic
AR37-80	SSRY181	191	197	190.78	196.49	7169	4237	42608	24330	0.7889	Polymorphic
AR37-80	SSRY182	159	159	159.39	159.39	384	384	2299	2299	0.3945	Monomorphic
AR37-80	SSRY19	215	215	214.25	214.25	2356	2356	14791	14791	1.0000	Polymorphic
Nachinyaya	SSRY19	197	209	197.29	209.25	3422	2015	21826	12636	0.7889	Polymorphic
AR37-80	SSRY38	106	121	106.15	120.84	14431	8774	94405	56578	0.7889	Polymorphic
Nachinyaya	SSRY38	106	106	106.20	106.20	23559	23559	145314	145314	0.7889	Polymorphic
AR37-80	SSRY5	106	127	105.85	127.38	19168	6371	127336	40373	0.3945	Polymorphic
Nachinyaya	SSRY5	106	106	105.76	105.76	20653	20653	134441	134441	0.7889	Polymorphic
AR37-80	SSRY51	259	259	259.40	259.40	32391	32391	296978	296978	1.0000	Polymorphic
Nachinyaya	SSRY51	278	299	277.34	298.68	12129	5172	82413	35486	0.3945	Polymorphic
AR37-80	SSRY52	267	267	267.28	267.28	8892	8892	60276	60276	0.7889	Polymorphic
Nachinyaya	SSRY52	257	263	256.63	263.13	6954	3968	47629	27878	0.7889	Polymorphic
AR37-80	SSRY63	285	295	284.63	295.37	9061	5004	56860	31367	0.7889	Polymorphic
Nachinyaya	SSRY63	285	285	284.54	284.54	13380	13380	83094	83094	0.7889	Polymorphic
AR37-80	SSRY9	259	263	258.69	262.50	29799	23791	192398	148920	0.3945	Monomorphic
Nachinyaya	SSRY9	259	263	258.67	262.52	16071	14174	104255	88006	0.3945	Monomorphic

Key: Table 2 shows the parental genotypes and SSR markers used for genotyping to identify polymorphic markers. GQ= genotype quality Allele sizes are also indicated for heterozygosity and monomorphic markers after parental screening. Markers that depicted similar alleles in both parents were not polymorphic and hence excluded except those that consisted of different alleles and allele sizes. Also a marker that amplified only one parental DNA was excluded.

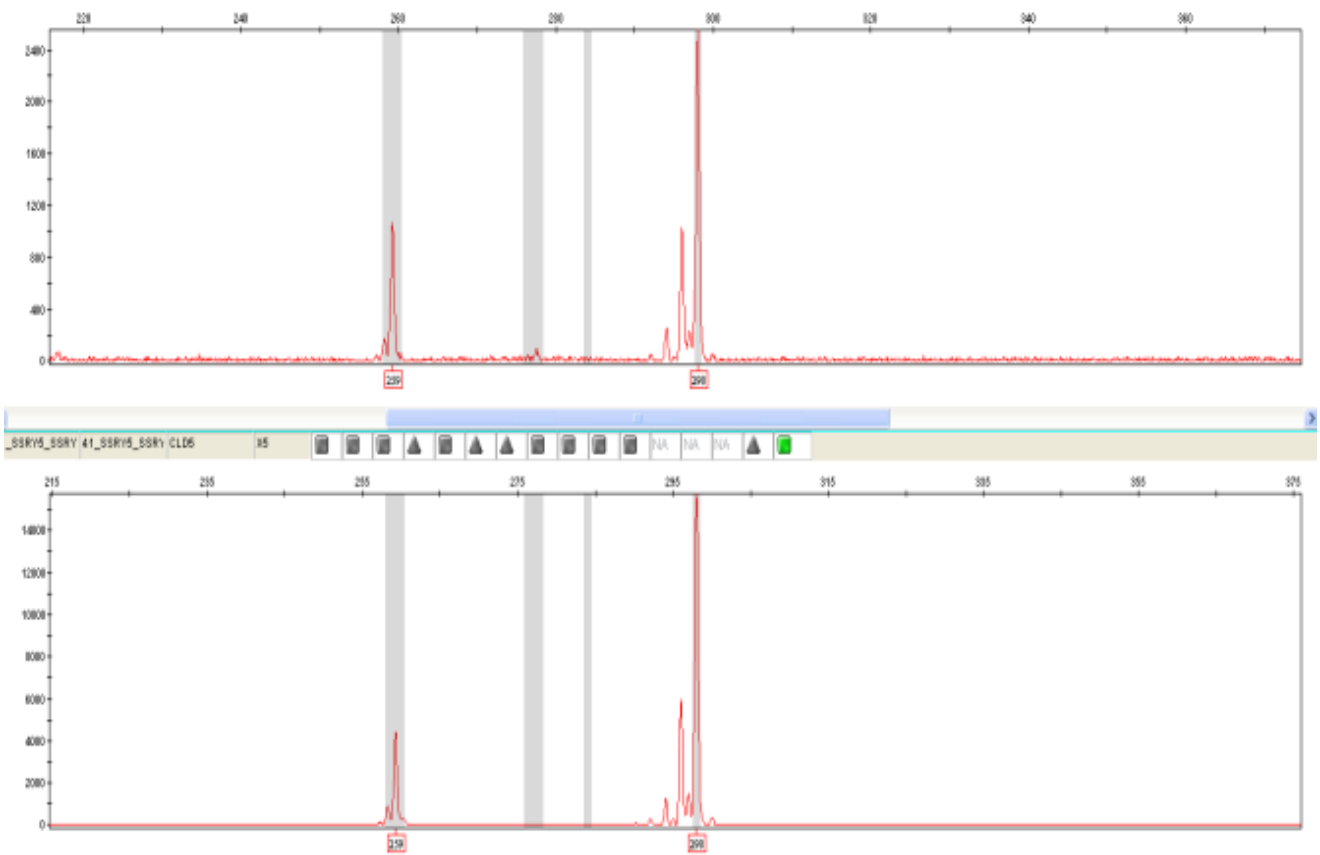

Plate 3: Genotype plot indicating alleles and allele sizes for polymorphic *SSRY171* marker with cassava (*Manihot esculenta* Crantz) F₁ hybrids. The allele size ranged from 289 to 303 (Y-axis).

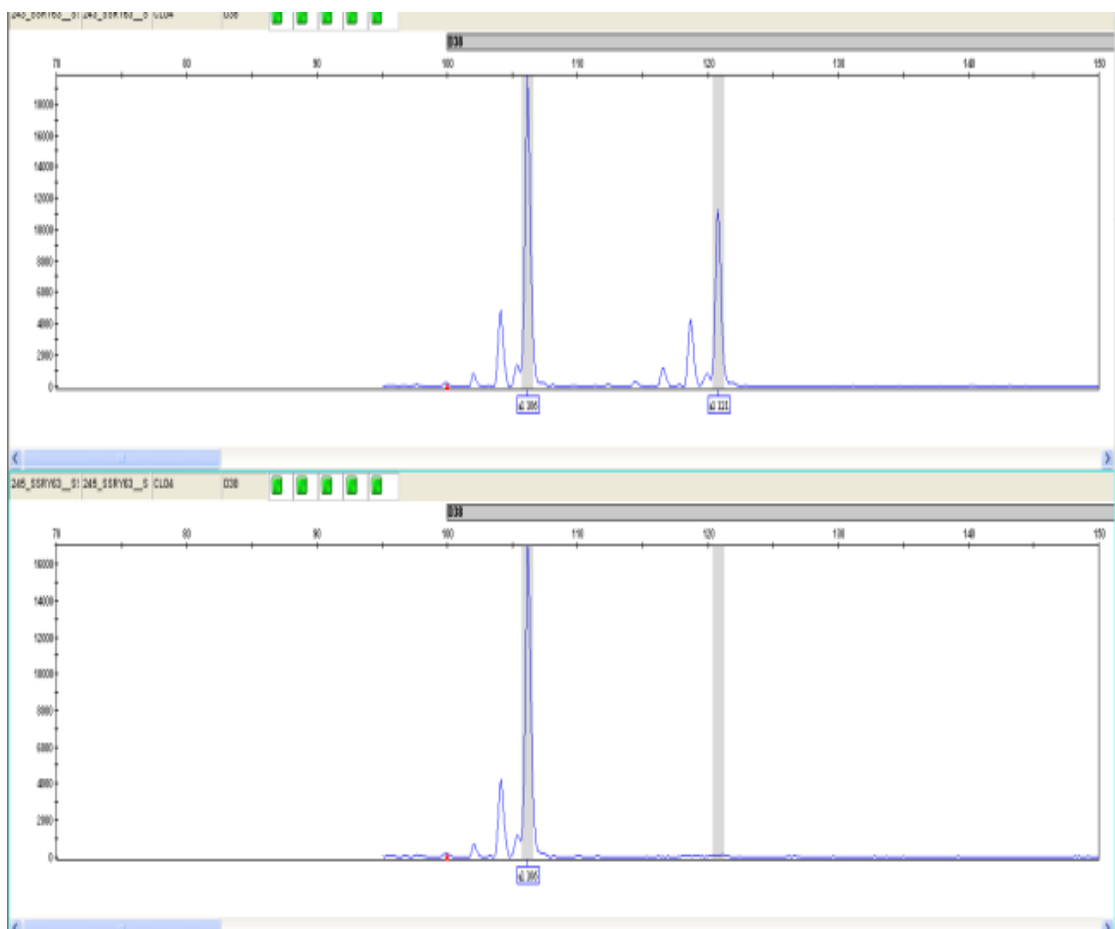

Plate 4: Genotype plot indicating alleles and allele sizes for polymorphic *SSRY63* marker with cassava (*Manihot esculenta* Crantz) F₁ hybrids. The allele sizes ranged from 285 to 295.

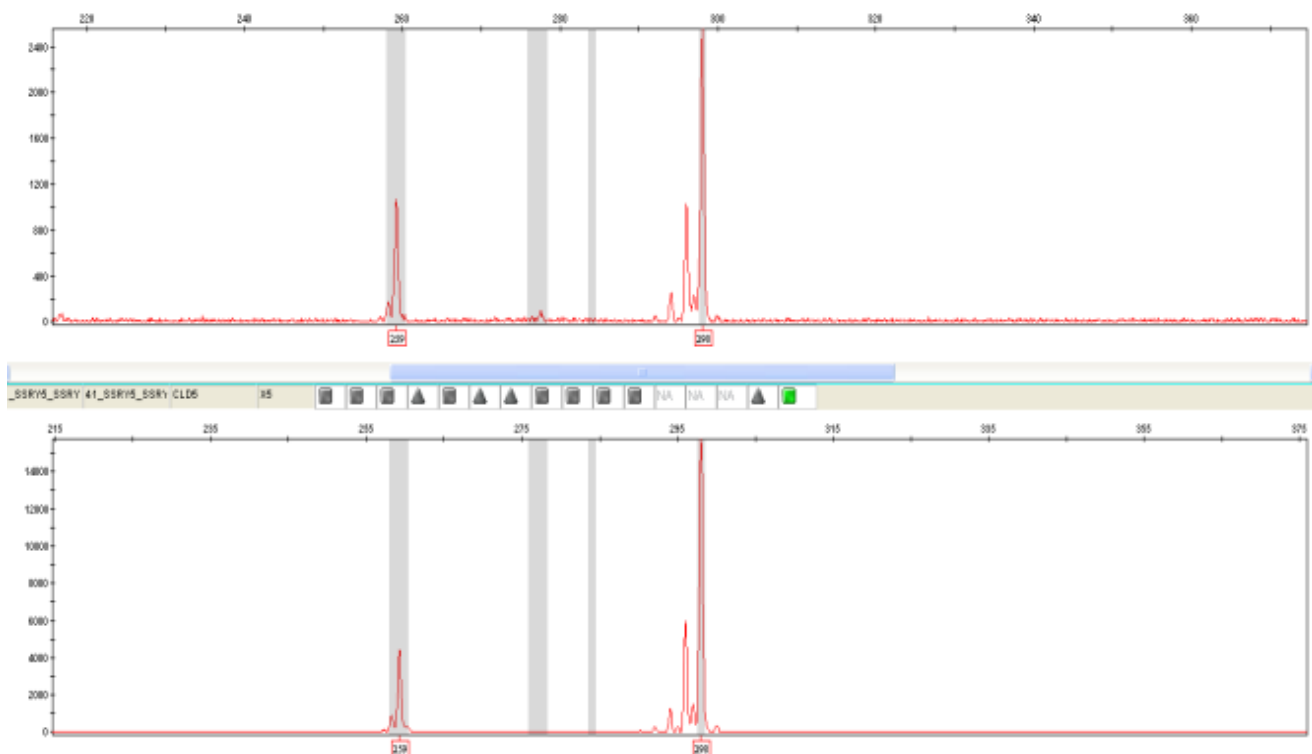

Plate 5: Genotype plot indicating various alleles and allele sizes for polymorphic marker SSRY5 with Cassava (*Manihot esculenta* Crantz) F₁ hybrids. The allele sizes ranged from 106 to 127.

Table 2: Allele sizes identified by SSR markers on Cassava F₁ hybrids developed from Nachinyaya × AR37-80 cross.

Sample ID.	NS911	SSRY12	SSRY151	SSRY169	SSRY171	SSRY19	SSRY38	SSRY5	SSRY51	SSRY52	SSRY63	Markers
Nachinyaya	123/123	254/261	180/185	99/99	289/289	197/209	106/106	106/106	278/299	257/263	285/285	
AR37-80	113/123	265/265	187/210	89/99	289/303	214/214	106/121	106/127	259/259	267/267	285/295	
NCAR1	113/123	261/265	185/210	89/99	289/289	-	106/121	106/106	259/299	263/267	285/285	
NCAR10	123/123	254/265	185/187	89/99	289/303	-	106/106	106/106	259/299	257/267	285/295	
NCAR101	-	261/265	185/210	89/99	289/303	209/214	106/121	106/127	259/299	263/267	-	
NCAR102	113/123	261/265	185/187	99/99	289/303	-	106/121	106/106	259/299	263/267	285/295	
NCAR103	113/123	261/265	185/210	89/99	289/303	209/214	106/106	106/127	259/299	263/267	285/295	
NCAR104	113/123	-	-	99/99	289/303	197/214	106/106	106/127	259/299	263/267	285/295	
NCAR105	123/123	261/265	185/210	89/99	289/303	209/214	106/121	106/127	259/299	-	285/295	
NCAR106	113/123	261/265	185/210	99/99	289/303	-	106/121	106/106	259/299	263/267	285/295	
NCAR107	123/123	254/265	180/210	99/99	289/303	-	106/121	106/106	259/299	257/267	285/285	
NCAR108	113/123	254/265	185/210	99/99	289/303	209/214	106/121	106/106	259/299	257/267	285/285	
NCAR109	113/123	261/265	180/210	89/99	289/303	-	106/106	106/127	-	263/267	285/295	
NCAR11	113/123	261/265	180/210	89/99	-	197/214	106/106	106/106	259/299	263/267	285/295	
NCAR110	123/123	254/265	180/210	89/99	-	197/214	106/106	106/127	259/299	257/267	285/285	
NCAR111	123/123	261/265	185/210	99/99	-	209/214	106/106	106/127	-	263/267	285/295	
NCAR112	113/123	261/265	185/210	89/99	-	209/214	106/121	106/127	259/299	-	285/295	
NCAR114	113/123	261/265	180/210	99/99	289/289	197/214	106/106	106/127	-	263/267	285/295	
NCAR115	113/123	254/265	185/187	89/99	289/303	209/214	106/121	106/106	-	257/267	285/285	
NCAR116	113/123	261/265	185/210	99/99	289/303	209/214	106/106	106/127	259/299	263/267	285/285	
NCAR118	113/123	261/265	180/210	99/99	-	-	106/106	106/127	-	263/267	285/285	
NCAR119	123/123	254/265	185/210	89/99	289/303	209/214	106/106	106/106	259/299	257/267	285/285	
NCAR12	123/123	261/265	185/210	89/99	-	197/214	106/121	106/106	259/278	263/267	285/285	
NCAR120	123/123	254/265	180/210	89/99	289/303	209/214	106/121	106/106	259/278	257/267	285/285	
NCAR121	113/123	254/265	180/187	99/99	289/303	209/214	106/106	106/106	259/299	257/267	-	
NCAR122	113/123	261/265	180/187	99/99	289/303	209/214	106/106	106/106	259/299	263/267	285/295	
NCAR123	113/123	261/265	180/210	99/99	289/289	209/214	106/121	106/127	259/299	263/267	285/285	
NCAR124	113/123	261/265	180/210	99/99	289/289	197/214	106/121	106/106	259/278	263/267	285/295	
NCAR125	123/123	254/265	180/210	89/99	289/303	209/214	106/106	106/106	-	257/267	285/285	
NCAR128	123/123	261/265	180/210	89/99	-	-	106/106	106/106	259/299	263/267	285/285	
NCAR129	123/123	254/265	180/210	99/99	289/303	197/214	106/106	106/127	259/278	257/267	285/295	
NCAR13	123/123	254/265	180/187	89/99	289/303	209/214	106/106	106/127	259/278	257/267	285/285	
NCAR130	113/123	254/265	185/210	99/99	289/303	209/214	106/106	106/106	259/278	257/267	285/285	
NCAR131	113/123	261/265	180/210	99/99	289/303	197/214	106/121	106/127	-	263/267	285/285	
NCAR133	123/123	254/265	185/210	89/99	289/303	197/214	106/106	106/127	259/278	257/267	285/295	
NCAR134	113/123	261/265	180/210	99/99	289/303	197/214	106/106	106/106	-	263/267	285/295	
NCAR134	123/123	254/265	180/210	89/99	289/303	209/214	106/121	106/127	259/278	257/267	285/295	
NCAR135	123/123	261/265	-	89/99	289/303	209/214	106/121	106/106	-	263/267	285/285	
NCAR136	113/123	254/265	185/210	89/99	289/303	209/214	106/106	106/127	-	257/267	285/295	
NCAR138	113/123	261/265	180/187	99/99	289/303	209/214	106/106	106/127	259/299	263/267	285/295	
NCAR139	113/123	261/265	180/210	89/99	289/303	197/214	106/121	106/106	259/299	-	285/285	
NCAR14	123/123	254/265	185/210	89/99	289/303	197/214	106/106	106/106	259/299	257/267	285/285	

Table2.continued

Sample ID.	NS911	SSRY12	SSRY151	SSRY169	SSRY171	SSRY19	SSRY38	SSRY5	SSRY51	SSRY52	SSRY63
NCAR151	123/123	261/265	185/210	89/99	-	-	106/106	106/106	-	263/267	285/295
NCAR153	113/123	261/265	185/210	99/99	289/303	-	106/121	106/106	259/278	263/267	285/285
NCAR157	113/123	261/265	185/210	99/99	-	-	106/106	106/106	-	263/267	285/285
NCAR16	113/123	254/265	185/210	99/99	289/303	197/214	106/106	106/127	-	257/267	285/285
NCAR17	123/123	254/265	180/210	89/99	289/303	209/214	106/106	106/127	259/299	257/267	285/295
NCAR176	123/123	261/265	180/210	89/99	289/303	209/214	106/121	-	259/278	263/267	285/295
NCAR178	113/123	261/265	180/210	99/99	289/303	209/214	106/121	106/127	259/278	263/267	285/295
NCAR18	123/123	254/265	180/187	99/99	289/289	197/214	106/106	106/106	259/299	257/267	285/285
NCAR181	-	254/265	180/210	89/99	289/303	209/214	106/106	106/127	259/299	257/267	285/295
NCAR182	123/123	261/265	180/210	89/99	289/303	-	106/106	106/106	-	-	285/285
NCAR184	113/123	261/265	185/187	89/99	289/303	-	106/106	106/127	259/278	263/267	285/285
NCAR185	113/123	261/265	185/210	99/99	289/303	-	106/121	106/106	259/278	-	285/285
NCAR187	113/123	261/265	180/210	99/99	289/303	197/214	106/106	106/127	259/299	263/267	285/285
NCAR19	123/123	261/265	185/210	99/99	289/303	-	106/106	106/106	-	263/267	285/295
NCAR2	123/123	261/265	180/210	99/99	289/303	-	106/121	106/127	259/278	263/267	285/295
NCAR20	123/123	261/265	185/210	89/99	289/303	197/214	106/121	106/106	259/299	263/267	285/295
NCAR21	123/123	254/265	185/210	99/99	289/303	-	106/121	106/127	259/299	257/267	285/285
NCAR211	-	261/265	185/187	99/99	-	197/214	106/106	106/106	259/299	263/267	285/285
NCAR212	-	261/265	185/210	89/99	-	-	106/106	106/127	259/299	263/267	285/285
NCAR214	-	254/265	185/210	99/99	289/303	209/214	106/121	106/127	259/278	257/267	285/295
NCAR215	123/123	261/265	185/187	99/99	289/303	-	106/121	106/127	259/299	263/267	285/285
NCAR22	113/123	261/265	185/187	99/99	289/303	-	106/106	106/106	259/299	263/267	285/295
NCAR227	-	254/265	180/210	99/99	-	197/214	106/106	106/106	259/299	257/267	285/285
NCAR229	123/123	254/265	185/210	89/99	289/303	197/214	106/106	106/127	259/299	257/267	285/285
NCAR23	113/123	261/265	180/210	89/99	289/303	197/214	106/121	106/127	259/278	263/267	285/285
NCAR235	123/123	261/265	180/210	89/99	289/303	209/214	106/121	106/127	259/299	263/267	285/285
NCAR236	123/123	261/265	-	89/99	289/303	-	106/106	106/106	-	263/267	285/285
NCAR237	123/123	254/265	185/210	99/99	289/303	197/214	106/121	106/127	259/299	257/267	285/295
NCAR238	113/123	261/265	185/187	89/99	289/303	-	106/121	106/127	259/278	263/267	285/295
NCAR239	113/123	261/265	185/210	89/99	289/303	209/214	106/106	106/127	259/278	263/267	285/285
NCAR24	123/123	261/265	180/187	99/99	289/303	197/214	106/106	106/127	259/299	263/267	285/295
NCAR241	113/123	261/265	180/187	99/99	289/303	-	-	106/106	-	263/267	-
NCAR243	113/123	254/265	185/210	99/99	289/289	197/214	106/121	106/106	259/278	257/267	285/295
NCAR245	113/123	261/265	185/210	99/99	289/289	197/214	106/106	106/127	-	263/267	285/295
NCAR246	123/123	261/265	185/210	99/99	289/303	209/214	106/121	106/106	259/299	263/267	285/285
NCAR247	123/123	254/265	180/210	99/99	289/303	-	106/106	106/106	259/278	257/267	285/285
NCAR248	113/123	261/265	185/210	99/99	289/289	197/214	106/121	106/106	259/299	263/267	285/295
NCAR249	123/123	254/265	180/210	99/99	289/303	-	106/121	106/127	259/299	257/267	285/295
NCAR25	113/123	254/265	180/210	99/99	289/303	197/214	106/121	106/127	259/278	257/267	285/285
NCAR260	123/123	261/265	180/187	99/99	289/303	209/214	106/106	106/106	-	263/267	285/285
NCAR264	123/123	254/265	185/187	89/99	289/303	197/214	106/106	106/106	259/299	257/267	285/285
NCAR268	123/123	254/265	180/210	89/99	289/303	-	106/106	106/106	259/278	257/267	285/295
NCAR27	113/123	-	-	99/99	289/289	209/214	106/106	106/106	259/299	257/267	285/285
NCAR273	123/123	254/265	180/210	89/99	289/303	-	106/121	106/127	259/278	257/267	285/285

Table2. Continued

Sample ID.	NS911	SSRY12	SSRY151	SSRY169	SSRY171	SSRY19	SSRY38	SSRY5	SSRY51	SSRY52	SSRY63
NCAR274	123/123	261/265	185/187	99/99	289/303	197/214	106/121	106/127	259/299	263/267	285/295
NCAR279	123/123	254/265	185/210	89/99	289/303	209/214	106/106	106/127	259/278	257/267	285/295
NCAR28	123/123	254/265	185/210	89/99	289/303	209/214	106/106	106/127	259/299	257/267	285/285
NCAR280	113/123	261/265	185/187	89/99	289/303	-	106/106	106/127	-	263/267	285/285
NCAR285	113/123	254/265	180/210	89/99	289/289	209/214	106/106	106/127	259/299	257/267	285/295
NCAR287	113/123	261/265	-	89/99	289/303	197/214	106/106	106/127	-	263/267	285/285
NCAR29	123/123	261/265	185/187	99/99	289/303	209/214	106/106	106/127	259/299	263/267	-
NCAR290	113/123	254/265	180/210	99/99	289/303	209/214	106/106	106/106	259/299	-	285/285
NCAR3	123/123	254/265	185/210	89/99	289/303	197/214	106/121	106/127	259/299	257/267	285/285
NCAR31	113/123	261/265	185/210	89/99	289/289	209/214	106/106	106/127	259/278	263/267	285/285
NCAR32	123/123	261/265	180/187	89/99	289/303	197/214	106/106	106/127	259/278	263/267	285/285
NCAR33	123/123	261/265	185/210	99/99	289/289	209/214	106/106	106/127	259/299	263/267	285/285
NCAR34	123/123	261/265	180/210	89/99	289/289	-	106/106	106/127	259/278	263/267	285/285
NCAR35	123/123	261/265	180/210	89/99	289/289	209/214	106/121	106/127	259/299	263/267	285/285
NCAR36	-	261/265	180/187	89/99	289/303	197/214	106/106	106/106	-	263/267	285/295
NCAR37	123/123	254/265	180/210	99/99	289/303	197/214	106/121	106/106	259/278	257/267	285/295
NCAR38	123/123	254/265	185/210	99/99	289/303	209/214	106/106	106/127	259/299	257/267	285/285
NCAR39	113/123	254/265	185/210	89/99	-	209/214	106/106	106/127	259/299	-	285/295
NCAR4	123/123	261/265	180/210	89/99	289/303	209/214	106/106	106/106	259/299	263/267	285/285
NCAR41	113/123	254/265	185/187	89/99	289/303	209/214	106/106	106/106	259/299	257/267	285/295
NCAR42	113/123	254/265	185/210	89/99	-	197/214	106/106	106/106	259/299	257/267	285/295
NCAR43	113/123	261/265	185/210	89/99	289/303	197/214	106/121	106/127	259/299	263/267	285/285
NCAR44	113/123	254/265	180/187	89/99	-	-	106/121	106/127	-	-	-
NCAR45	113/123	261/265	180/187	89/99	-	197/214	106/106	106/106	259/299	263/267	285/295
NCAR46	113/123	261/265	185/210	89/99	289/303	209/214	106/121	106/106	259/299	263/267	285/295
NCAR47	123/123	261/265	185/210	99/99	289/289	197/214	106/106	106/127	-	263/267	285/285
NCAR49	123/123	254/265	185/210	89/99	289/303	197/214	106/106	106/127	259/278	257/267	285/285
NCAR5	113/123	254/265	180/210	89/99	289/289	-	106/106	106/127	259/299	257/267	285/295
NCAR50	123/123	254/265	185/210	99/99	289/303	197/214	106/106	106/127	259/299	257/267	285/285
NCAR51	113/123	261/265	185/187	99/99	289/289	209/214	106/121	106/106	259/299	263/267	285/285
NCAR52	123/123	261/265	180/187	99/99	289/303	209/214	106/121	106/127	-	263/267	285/295
NCAR53	113/123	261/265	180/210	89/99	289/303	197/214	106/121	106/106	259/299	263/267	285/285
NCAR54	123/123	261/265	185/210	89/99	289/303	209/214	106/106	106/106	259/278	263/267	285/295
NCAR55	113/123	261/265	185/187	99/99	289/303	-	106/106	106/127	-	263/267	285/285
NCAR56	123/123	254/265	180/210	99/99	-	209/214	106/106	106/106	259/278	257/267	285/285
NCAR57	113/123	261/265	185/210	99/99	-	209/214	106/121	106/127	259/299	263/267	285/295
NCAR58	-	254/265	185/210	99/99	289/303	209/214	106/106	106/106	259/278	257/267	285/285
NCAR59	123/123	261/265	185/210	89/99	-	197/214	106/106	106/106	259/278	263/267	285/285
NCAR6	113/123	261/265	185/187	99/99	289/303	197/214	106/106	106/106	259/299	263/267	285/285
NCAR60	123/123	261/265	185/210	99/99	289/303	209/214	106/106	106/127	259/299	263/267	285/295
NCAR61	123/123	254/265	180/210	99/99	289/303	209/214	106/121	106/127	259/299	257/267	285/285
NCAR62	113/123	254/265	185/210	99/99	289/289	209/214	-	106/106	259/299	257/267	285/295
NCAR63	123/123	261/265	180/210	99/99	289/303	197/214	106/106	106/127	259/278	263/267	285/285
NCAR64	123/123	254/265	185/210	89/99	289/303	197/214	106/121	106/106	-	257/267	285/295

Table 2. Continued

Sample ID.	NS911	SSRY12	SSRY151	SSRY169	SSRY171	SSRY19	SSRY38	SSRY5	SSRY51	SSRY52	SSRY63
NCAR65	123/123	261/265	185/187	99/99	289/303	-	106/106	106/106	259/278	263/267	285/295
NCAR66	113/123	261/265	185/210	99/99	-	-	106/106	106/127	259/278	263/267	285/295
NCAR68	113/123	261/265	185/187	99/99	289/303	-	106/121	106/127	259/299	263/267	285/285
NCAR69	123/123	261/265	180/210	99/99	289/303	197/214	106/106	106/127	259/299	263/267	285/295
NCAR7	123/123	261/265	180/210	89/99	289/303	197/214	106/106	106/106	259/278	263/267	285/295
NCAR70	113/123	254/265	185/210	99/99	289/303	209/214	106/121	106/127	-	257/267	285/295
NCAR71	123/123	261/265	180/210	89/99	289/303	-	106/106	106/127	259/299	263/267	285/285
NCAR72	113/123	261/265	185/187	99/99	289/303	197/214	106/106	106/127	-	263/267	285/285
NCAR73	123/123	254/265	180/210	99/99	289/303	209/214	106/121	106/127	-	257/267	285/295
NCAR74	113/123	261/265	185/210	89/99	289/303	209/214	106/106	-	259/278	-	285/295
NCAR76	113/123	254/265	185/210	89/99	289/303	197/214	106/121	106/127	259/278	257/267	285/295
NCAR77	123/123	261/265	180/210	89/99	289/303	197/214	106/121	106/106	259/299	263/267	285/295
NCAR78	-	254/265	180/210	99/99	289/303	197/214	106/121	106/127	259/278	257/267	285/285
NCAR79	113/123	254/265	180/210	89/99	289/303	209/214	106/121	106/106	259/278	257/267	285/295
NCAR8	113/123	254/265	185/210	89/99	289/303	197/214	106/121	106/127	259/299	257/267	285/285
NCAR80	123/123	254/265	180/210	89/99	289/303	209/214	106/106	106/106	-	257/267	285/285
NCAR81	113/123	261/265	180/210	99/99	-	197/214	106/121	106/127	-	263/267	285/295
NCAR82	113/123	254/265	180/210	89/99	289/303	209/214	106/121	106/127	259/299	257/267	285/295
NCAR83	123/123	254/265	185/210	99/99	289/303	209/214	106/121	106/127	-	257/267	285/295
NCAR84	113/123	254/265	185/210	89/99	289/303	197/214	106/121	106/106	259/278	257/267	285/285
NCAR85	-	254/265	180/210	89/99	289/303	-	106/121	106/106	259/299	257/267	285/285
NCAR86	123/123	261/265	185/187	99/99	289/303	197/214	106/106	106/127	259/299	263/267	285/295
NCAR87	113/123	261/265	185/210	89/99	289/303	197/214	106/106	-	-	263/267	285/285
NCAR88	113/123	261/265	185/210	89/99	289/303	209/214	106/121	106/127	-	263/267	-
NCAR89	113/123	261/265	185/210	89/99	289/303	197/214	106/106	106/127	-	263/267	-
NCAR9	113/123	254/265	180/210	89/99	289/303	-	106/121	106/106	259/299	257/267	285/285
NCAR90	123/123	261/265	180/210	89/99	289/303	209/214	106/121	106/127	-	263/267	-
NCAR91	123/123	261/265	185/210	89/99	289/303	197/214	106/121	106/106	-	263/267	-
NCAR92	113/123	254/265	185/210	99/99	289/303	197/214	106/106	106/106	-	257/267	-
NCAR93	113/123	254/265	185/187	99/99	289/303	197/214	106/106	106/127	-	257/267	-
NCAR94	113/123	254/265	180/187	99/99	289/303	209/214	106/106	106/106	-	257/267	-
NCAR95	113/123	261/265	185/187	99/99	289/303	-	106/121	106/127	-	263/267	-
NCAR96	113/123	254/265	185/210	99/99	289/303	209/214	106/121	106/127	259/278	257/267	285/295
NCAR97	113/123	254/265	180/187	89/99	289/303	197/214	106/121	106/127	259/278	257/267	285/285
NCAR98	113/123	254/265	180/187	89/99	289/303	209/214	106/121	106/127	259/299	257/267	285/295
NCAR99	113/123	261/265	185/210	99/99	289/289	-	106/106	106/127	-	263/267	285/295
NCAR291	123/123	261/265	180/210	99/99	289/303	197/214	106/106	106/127	259/278	263/267	285/295
NCAR292	123/123	261/265	185/210	99/99	289/303	197/214	106/121	106/106	259/299	263/267	285/295
NCAR293	123/123	254/265	185/210	89/99	289/289	209/214	106/121	106/127	259/299	257/267	285/295
NCAR306	123/123	254/265	180/210	89/99	289/289	209/214	106/121	106/106	259/278	257/267	285/295
NCAR313	123/123	261/265	180/210	99/99	289/303	197/214	106/106	106/127	259/299	-	285/285
NCAR314	123/123	254/265	185/187	99/99	289/303	197/214	106/121	106/106	259/299	263/267	285/285
NCAR315	123/123	261/265	180/210	99/99	289/289	197/214	106/106	106/127	259/278	-	285/285

Table 2. Continued

Sample ID.	NS911	SSRY12	SSRY151	SSRY169	SSRY171	SSRY19	SSRY38	SSRY5	SSRY51	SSRY52	SSRY63
NCAR316	123/123	261/265	180/187	89/99	289/303	-	106/121	106/106	259/299	-	285/285
NCAR317	123/123	254/265	185/187	-	-	209/214	106/121	106/106	-	-	285/295
NCAR318	123/123	261/265	185/210	99/99	-	197/214	106/121	106/106	259/278	-	285/285
NCAR320	123/123	254/265	185/187	99/99	-	209/214	106/121	106/106	259/278	-	285/285
NCAR321	123/123	261/265	180/210	99/99	289/303	197/214	106/121	106/127	259/299	-	285/295
NCAR322	123/123	254/265	180/210	89/99	289/303	-	106/121	106/106	-	257/267	285/295
NCAR323	123/123	254/265	185/210	99/99	289/303	-	106/121	106/127	-	257/267	285/295
NCAR324	123/123	254/265	185/210	-	289/303	209/214	106/106	106/106	259/278	257/267	285/285
NCAR325	123/123	254/265	185/210	89/99	289/303	197/214	106/106	106/106	259/299	257/267	285/295
NCAR326	123/123	261/265	185/210	99/99	289/303	209/214	106/106	106/127	259/299	263/267	285/295
NCAR327	123/123	261/265	180/210	99/99	289/303	197/214	106/121	106/127	259/299	263/267	285/285
NCAR328	123/123	254/265	180/210	99/99	289/303	209/214	106/121	106/106	259/278	257/267	285/295
NCAR329	123/123	261/265	180/210	89/99	289/303	209/214	106/106	106/106	259/299	263/267	285/285
NCAR331	-	261/265	180/210	99/99	289/303	197/214	106/106	106/127	259/299	263/267	285/285
NCAR332	123/123	254/265	185/210	99/99	289/303	197/214	106/106	106/127	-	257/267	285/285
NCAR333	123/123	261/265	185/187	99/99	289/303	197/214	106/106	106/127	259/278	263/267	285/295
NCAR335	123/123	261/265	185/187	99/99	289/303	197/214	106/121	106/106	-	263/267	285/295
NCAR336	123/123	254/265	180/187	99/99	289/303	209/214	106/121	106/127	259/299	257/267	285/295
NCAR337	123/123	254/265	185/210	99/99	289/303	209/214	106/106	106/127	259/299	257/267	285/285
NCAR338	123/123	254/265	180/210	89/99	289/289	209/214	106/106	106/106	259/278	257/267	285/285
NCAR339	123/123	254/265	185/210	-	289/303	197/214	106/121	106/127	259/299	257/267	285/295
NCAR340	123/123	254/265	185/210	-	289/303	197/214	106/121	106/106	259/278	257/267	285/295
NCAR341	123/123	254/265	185/210	-	289/303	209/214	106/121	106/127	259/278	257/267	285/295
NCAR344	123/123	261/265	185/187	99/99	289/303	209/214	106/106	106/106	259/299	263/267	285/295
NCAR345	123/123	261/265	-	-	289/303	197/214	106/106	106/127	259/278	263/267	-
NCAR346	123/123	254/265	180/187	-	289/303	197/214	106/121	106/106	259/278	257/267	285/285
NCAR347	123/123	261/265	180/210	-	289/303	197/214	106/106	106/106	259/278	263/267	285/285
NCAR349	123/123	254/265	180/210	99/89	289/303	209/214	106/121	106/106	259/299	257/267	285/295
NCAR350	123/123	261/265	-	99/89	289/303	197/214	106/121	106/127	259/278	263/267	285/285
NCAR351	123/123	261/265	180/210	89/99	289/303	197/214	106/121	106/127	259/278	263/267	285/285
NCAR352	123/123	254/265	180/210	89/99	289/303	197/214	106/106	-	259/299	257/267	285/285
NCAR353	123/123	261/265	180/210	89/99	289/303	209/214	106/121	106/127	259/299	263/267	285/295
NCAR354	123/123	254/265	185/210	89/99	289/303	209/214	106/121	106/106	259/299	257/267	-
NCAR355	123/123	254/265	180/210	89/99	289/303	209/214	106/121	106/127	259/278	257/267	285/295
NCAR356	123/123	254/265	185/210	99/99	289/303	197/214	106/121	106/127	259/299	257/267	285/295
NCAR357	123/123	254/265	-	99/99	289/303	209/214	106/106	-	259/299	257/267	285/285
NCAR358	123/123	254/265	185/210	99/99	289/303	209/214	106/106	-	-	257/267	285/295
NCAR359	123/123	254/265	180/210	89/99	289/289	209/214	106/121	-	-	257/267	285/295
NCAR360	123/123	261/265	180/210	89/99	289/289	209/214	106/121	-	-	263/267	285/285
NCAR361	123/123	261/265	180/210	89/99	289/303	197/214	106/121	-	259/278	263/267	285/295
NCAR362	123/123	261/265	185/210	89/99	289/303	209/214	106/106	-	259/299	263/267	285/295
NCAR363	123/123	261/265	185/210	89/99	289/303	197/214	106/121	-	259/299	263/267	285/285
NCAR364	123/123	261/265	180/187	89/99	289/303	197/214	106/121	-	259/299	263/267	285/285
NCAR365	123/123	254/265	185/210	99/99	289/303	197/214	106/106	106/106	259/299	257/267	285/285

Table2. Continued

Sample ID.	NS911	SSRY12	SSRY151	SSRY169	SSRY171	SSRY19	SSRY38	SSRY5	SSRY51	SSRY52	SSRY63	Mrkers
NCAR366	123/123	261/265	180/210	99/99	289/303	209/214	106/106	106/106	259/299	263/267	285/295	
NCAR367	123/123	261/265	185/210	89/99	289/289	197/214	106/106	106/106	259/299	263/267	285/295	
NCAR368	123/123	261/265	185/210	89/99	289/303	197/214	106/121	106/127	-	263/267	285/285	
NCAR370	123/123	261/265	185/210	89/99	289/303	209/214	106/121	106/127	-	263/267	-	
NCAR371	123/123	254/265	185/187	89/99	289/303	197/214	106/106	106/127	-	257/267	285/295	
NCAR372	123/123	261/265	185/210	-	289/303	197/214	106/106	106/127	259/278	263/267	-	
NCAR373	123/123	254/265	185/210	89/99	289/303	197/214	106/106	106/127	259/278	257/267	285/285	
NCAR374	123/123	254/265	180/210	99/99	289/289	209/214	106/106	106/106	259/299	257/267	285/285	
NCAR376	123/123	261/265	185/210	99/99	289/289	-	106/106	106/106	259/278	263/267	285/285	
NCAR377	123/123	254/265	185/210	89/99	289/303	197/214	106/106	106/106	-	257/267	-	
NCAR378	123/123	261/265	185/210	89/99	289/303	197/214	106/121	106/106	259/299	263/267	285/285	
NCAR379	123/123	254/265	180/210	99/99	289/303	209/214	106/121	106/127	-	257/267	285/285	
NCAR380	123/123	261/265	185/210	89/99	289/303	209/214	106/121	106/106	259/299	263/267	285/295	
NCAR381	123/123	261/265	180/210	99/99	289/303	209/214	106/121	106/106	-	263/267	-	
NCAR382	123/123	261/265	185/210	99/99	289/303	209/214	106/121	106/127	259/299	263/267	-	
NCAR383	123/123	261/265	-	99/99	289/303	209/214	106/121	106/127	-	263/267	-	
NCAR384	123/123	254/265	180/210	-	289/289	209/214	106/106	106/127	259/278	257/267	285/295	
NCAR385	123/123	254/265	185/210	99/99	289/303	197/214	106/106	106/106	259/278	257/267	285/285	
NCAR386	123/123	261/265	185/210	99/99	289/289	209/214	106/106	106/106	259/278	263/267	285/285	
NCAR387	123/123	254/265	180/210	-	289/303	197/214	106/121	106/106	259/299	257/267	-	
NCAR388	123/123	254/265	185/187	-	289/303	209/214	106/106	106/127	259/299	257/267	285/285	
NCAR390	123/123	261/265	180/210	99/99	289/289	197/214	106/121	106/106	259/299	263/267	285/295	

Key: Sample ID=Sample identification.

NCAR= A progeny derived from a cross between Nachinyaya and AR37-80.

NS and SSRY represent the SSR markers used to identify the true hybrids

Alleles separated by slash show the heterozygous genotypes per marker and similar alleles indicate that two parents shared one common allele.

'-' indicates missing data for the unamplified genotypes for a particular marker.

3.7 Discussion

Good quality genomic DNA with high DNA concentration facilitated SSR genotyping by ABI Prism 3730 sequencer. DNA markers are useful in the identification of closely related cultivars and hybrids (Mishra *et al.*, 2011). The degree of nucleic acids purity can be obtained through examination of the absorption at other wave lengths in proteins and carbohydrates which have known maximum absorption. Proteins absorb strongly at 280nm and the polysaccharides are identified at 230nm. The A₂₆₀/280 ratio rules of thumb for DNA and RNA quality is 1.8 to 2.0 respectively, however, the actual ratio depends on the composition of the nucleic acid. The ratio of RNA is higher because of the high ratio of Uracil (4.00) compared to thymine ratio in DNA (1.47) and the 260/280 ratio is a weighted average of all nucleotides in the nucleic acid. The DNA quality was fairly good and facilitated further analysis.

In this study, only fourteen SSR markers showed variants between the tolerant and susceptible cassava cultivars. In addition, when interpreting SSR marker polymorphism using height and peak generated from GeneMapper, it is evident that the larger sized allele indicates short peak height and small peak area (Plate 1, 2, and 3). The allele size, height and peak area were used to assess the polymorphic nature of the cassava SSR markers used in this study.

The SSR markers used to verify hybrids did indeed distinguish the true F₁ genotypes. (Table 2). However, the variation in the loci amplified in the F₁ genotypes by the SSR markers could be emanating from heterozygosity of the parents Nachinyaya and AR37-80. Evidently, SSRY151 amplified multi loci 185/210, 185/187, 180/210 and 180/187, on the hybrid. None the less, the SSR markers were efficiently used to select the true hybrids.

Mapping population should consist entirely of Nachinyaya × AR37-80, but in reality, it is likely that some self-pollinations occurred, leading to selfs (S₁), and some out crossing occurred resulting in off-types. It is therefore necessary that only true Nachinyaya and AR37-80 hybrids are genotyped and that selfs and off-types are discarded before SNP genotyping and genetic linkage construction. SSR markers are an excellent tool for parentage verification and hybridity confirmation (Asif *et al.*, 2009). The SSR markers used in this study were capable of detecting true hybrids and off-types and selfs not needed for further analysis. Similarly Gomez *et al.*, (2008) and Otti *et al.*, (2011), reported that co-

dominant SSR markers were capable of detecting homozygous and polymorphic alleles in the parents. This was important because controlled crosses could not completely eliminate cross-contamination as the case in this study. In addition SSR markers have been used for verification of inter-specific crosses (Terzic *et al.*, 2006) in crops such as cotton (Dongre and Parkri, 2005; maize (Salgado *et al.*, 2006 and rice (Tamilkumar *et al.*, 2009; Asif, 2009) studies. In this study 94.8% (257 true hybrids) were identified out of F₁ 271 hybrids using 11 polymorphic and co-dominant SSR markers. This is an indication that parents used to develop the mapping population had sufficient variation at both phenotypic and DNA sequence levels. The variation at DNA level is essential for tracing the recombination frequencies during meiosis. The large number of hybrids showed that it is good mapping population and it confirms the efficiency of controlled crossing technique in cassava. In related studies, Mba *et al.*, (2001), Nandakumar *et al.*, (2004) and Noveno *et al.*, (2008) identified true cassava hybrids using 186 SSR markers from a seed lot of diverse parental material. From the above findings, it was possible to detect true hybrids (heterozygotes) and homozygotes because the female and male contributed allele to the hybrid. As a result all the genotypes that had similar allele size as the female parent indicated that the crossing was not successful and were not considered further analysis.

3.8 Conclusion

The results from the determination of hybrids showed that there was a sufficient recombination frequency from a cross of Nachinyaya and AR37-80 and that the mapping population can be used for further research to locate genes for cassava brown streak disease (CBSD) resistance for application in marker-assisted selection (MAS).

3.9 References

- Alpert, K.B. and Tanksley, S.D. 1996. High resolution mapping and isolation of a yeast artificial chromosome contig containing fw2.2: a major fruit weight quantitative trait locus in tomato. *Proceedings of the national academy of science of United States of America*, 93:15503-15507.
- Asif, M., Rahman, M.U., Mirza J.I. and Zafar, U. 2009. Percentage confirmation of Cotton hybrids using molecular markers. *Pak Journal of Botany*, 41:695-701.
- Dellaporta, S.L., Wood, J. and Hicks, J.B. 1983. A plant DNA mini-preparation: version II. *Plant Molec. Biol. Rep.*, 1:19-21.
- Dogre, A., Parkri, V. 2005. Identification of cotton hybrids through the combination of PCR based RAPD, ISSR and microsatellite markers. *J. Plant Biochem. Biotech.*, 14: 53-55.
- Gomez, S.M., Denwar N.N., Ramasubamanan, T., Simpson, C.E., Burou, G., Burker, J.J., Puppala, N. 2005. Identification of Peanut hybrids using microsatellite markers and horizontal polyacrylamide gel electrophoresis. *Peanut Sci.* 35: 123-129.
- Kawuki, R.S., Ferguson, M., Labuschagne, M.T., Herselman, L., Orone, J., Ralimanana, I., Bidiaka, M., Lukambo, S., Kanyange, M.C., Gashaka, G., Mkamil, G., Gethi, J., Obiero, H. 2011. Variation in quantitative and qualitative traits of cassava germplasm from selected national breeding programmes in sub-Saharan Africa. *Field Crop Research.*
- Kulembeka, H.P.K. 2010. Genetic linkage mapping of field resistance to cassava brown streak disease in cassava (*Manihot esculenta* Crantz) landraces from Tanzania. PhD, Thesis. University of the Free State, Bloemfontein, South Africa.
- Mba, R.E.C., Stephenson, P., Edwards, K., Melzer, S., Nkumbira, J., Gullberg, U., Apel, K., Gale, M., Tohme, J., Fregene, M. 2001. Simple sequence repeat (SSR) markers survey of the cassava (*Manihot esculenta* Crantz) genome: towards an SSR-based molecular genetic map of cassava. *TAG Theor. Appl. Genet.* 102:21-31.
- Messeguer, R., Ganal M., de Vincente M.C., Young N.D., Bolkan, H and Tanksley S.D. 1991. High resolution RFLP map around the root knot nematode resistance gene (*Mi*) in tomato. *Theor. Appl. Genet.* 82: 529-536.
- Mishra, M.K., Suresh, N., Asha, M., Bhat, A.M., Suyraprakash, N., Kumar, S.S., Kumar, A and Jayarama. 2011. Genetic molecular analysis of Coffee Arabica (Rubiaceae) hybrids using SRAP markers.
- Noveno, D.P., Sana E.A. and Perez, L.M. 2008. Comparative hybrid detection of *Rf*- linked in Rice (*Oryza sativa* L). *NVSU Research Journal*, xv: 1 and 2.
- Otti, G., Fakoya, A., Andrew, I. and Gedil, M. 2011. Development of genomic tools for verification of hybrids and selfed progenies in cassava. *African Journal of Biotechnology*, 10:17400-17408.
- Powell, W., Machray, G., Proran, J. 1996. Polymorphism revealed by simple sequence repeats. *Trends Plant Sci.*, 38:215-222.
- Rongwen, J., Akkaya, M.S., Bhagwat, A.A., Lavi, U and Cregan, P.B. 1995. Use of microsatellite DNA markers for soybean genotype identification. *Theor. Appl. Genet.* 90:43-48.
- Salgado, K.C.P.C., Viera, M.G.G.C., Pinho, E.V.R., Guimara-en seeds of hybrid maize using molecular markers. *Revista Brasileira de sementes.* 28:169-175.
- Semagn, K. 2010. The genetic dissection of quantitative traits in crops. *Microbial biotechnology.* 13.
- Stuber, C.W., Edwards, M.D. and Wendel, J.F. 1987. Molecular marker-facilitated investigations of quantitative trait loci in maize II. Factors influencing yield and its component traits. *Crop Sci.* 27:639-648.

- Tamilkumar, P., Jerlin, R., Ganeson, K., Senthil, N., Jeevan, R., Raveenderan, M.2009. Fingerprinting of rice hybrids and their parental lines using microsatellite markers and their utilization in genetic purity assessment of hybrid rice. *Res. J. Seed.* 2:40-47.
- Terzic, S., Atlagic, J., Rankoni, D. 2006. Characterization of F₁hybrids between wild *Helianthus annus*L. population and cultivated sunflower. *Genetika*38:159-168.
- Young, N.D. 2000. Constructing a plant genetic linkage map with DNA, R.L, Phillips and J.K, Vasil (eds), DNA-based markers in plants, 1. Kluwer Academic Publishers. Printed in the Netherlands.

CHAPTER FOUR

Construction of a SNP- based genetic linkage map

4.1 Abstract

Linkage analysis is important for genetic analysis and breeding for resistance to important biotic stresses. Molecular markers linked to disease resistance genes are essential for marker assisted breeding to combat cassava brown streak disease. The objective of this study was to develop a SNP-based genetic linkage map of F₁ hybrid derived from a cross between Nachinyaya and AR37-80 to be used in marker-assisted selection (MAS). DNA from leaves of 257 F₁cassava genotypes and two parents was genotyped using SNP markers. Five hundred and fourteen SNPs that previously were found to be polymorphic among the parents were used for genotyping F₁ hybrids. The SNP markers were assessed against segregation distortion basing on *Chi*-square values and markers with high distortion were excluded and finally 426 SNP markers were used to construct a genetic linkage map using JoinMap^(R) 4.1 software. The map consisted of 20 linkage groups and spanned 1697 cM with average distance between markers of 3.98 cM. The critical linklod was 3.0. A total of 209 SNP markers were common in both maps and 217 SNP markers were mapped in this study for the first time.

Key words: Genetic linkage map, Single nucleotide polymorphism, Cassava brown streak disease.

4.2 Introduction

Linkage analysis is done basing on how often the alleles of particular loci are inherited together or exchange their genetic materials due to crossing-overs during meiosis. The genetic information for closely linked loci is inherited together to the next generation. Genetic linkage map is useful in QTL analysis; marker assisted breeding and map-based gene cloning. It is also a prerequisite for the study of inheritance of qualitative and quantitative traits and integration of molecular information for marker-assisted selection (MAS) (Morgante and Salamini, 2003; Troggio, 2007). It is the first step towards marker-assisted analysis of traits of agronomic importance since it permits association of molecular markers with traits of agronomic importance. Construction of a genetic linkage map using a cassava F₁mapping population will be expected to greatly contribute in gaining insights into the genetics of CBSD resistance and identification of molecular markers linked to CBSD

resistance for use in MAS. In related studies, linkage maps have been developed in barley (*Hordeum vulgare*), birdsfoot (*Lotus japonicas*), chinese cabbage (*Brassica rapa*), cucumber (*Cucumis sativus*), soybean (*Glycine max*), cassava (*Manihot esculenta*), Jatropha (*Jatropha curcas*) and rice (*Oryza sativa*) using molecular markers such as RAPD, RFLP, AFLP, SSR and SNPs (Liu *et al.*, 2009;Ren *et al.*,2009;Xia *et al.*, 2010; Liu *et al.*, 2011; Wang *et al.*, 2011; Nguyen *et al.*, 2012., Rabbi *et al.*, 2012).

The application of MAS very useful, however, it is influenced by the relationship between the markers and the genes of particular interest and it depends on the relationship between marker position, gene, linkage disequilibrium (Dekkers, (2003). Gene-assisted selection occurs when a molecular marker is located within the gene of interest and is this facilitates the application of markers; however, such markers are difficult to be found. On the other hand, linkage disequilibrium MAS occurs when certain combinations of alleles are inherited together and is caused by closely physical position of the markers and genes of interest or cross breeding of the recent generations. In addition selection can also be effected using a marker that is not in linkage disequilibrium throughout the genome and is very difficult situation for MAS application (Dekkers, (2003; FAO, 2003).

Single nucleotide polymorphisms (SNPs) have single nucleotide exchanges insertions and deletions between various alleles or DNA sequences (McCouch *et al.*, 2010). They are generally biallelic, are highly reproducible, have high automation potential and low running costs per data point compared to SSR markers and are abundant across the genome (Schmitt *et al.*, 2010). Integration of high throughput SNP genotyping facilitates accelerated genetic gain in a breeding program (McCouch *et al.*, 2010). The biallelic problem is compensated for by the frequency of SNPs and their amenity to high throughput screening (Syvanen, 2001). SNP markers are appropriate molecular markers for construction of dense linkage maps and in genome association research (Wang *et al.*, 2005). Hyten *et al.*, (2010), developed a high resolution genetic map using 444 soybean recombinant inbred lines with 1,790 SNP markers. These markers have been used in the creation of genetic linkage maps in model grass (*Brachypodium*) using 558 SNPs and 476 F₂ genotypes and also in Soybean (*Glycine max*); *Curcubita pepo* with 304 SNPs and 146 F₂ genotypes (Yang and Jeong, 2008; Garvin *et al.*, 2011; Esteras *et al.*, 2012). Currently, SNP is an important tool in the development of molecular markers for important genes, traits and biodiversity assessment in crop plants.

In genetic map construction, markers are assigned into linkage groups and the marker orders determined (Wu *et al.*, 2003; Mllinarri *et al.*, 2009). SNP-based high-resolution genetic linkage map enables fine mapping of QTLs (Glanowski *et al.*, 2002; Aslam *et al.*, 2010). High density genetic maps require a larger number of progeny and loci (Troggio *et al.*, 2007, Chen; 2007). From a SNP resource of 2954 putative SNPs identified from ESTs, 1536 SNP markers from 1170 contigs were selected for validation by GoldenGate assay and 1190 SNPs were validated in 53 cassava accessions (Ferguson *et al.*, 2011). The construction of a genetic linkage map requires the development of an appropriate mapping population of appropriate sample size, selection of marker types for genotyping the population, and genotyping the progeny using the identified polymorphic markers. Calculation of pairwise recombination frequencies between markers, establishment of linkage groups, map distance estimation and determination of map order is done using statistical programs. The objective of this experiment was to develop a SNP-based genetic linkage map from F₁ cassava hybrids.

4.3 Materials and Methods

4.3.1 Genotyping

Two hundred and fifty seven F₁ genotypes derived from Nachinyaya (CBSD tolerant) × AR37-80 (CBSD susceptible) and authenticated by eleven SSR markers were genotyped using single nucleotide polymorphism (SNP) using KASPar technology. The DNA samples from 257 hybrids and 2 parents were arrayed in 96-well reaction plates and SNP genotyped at KBiosciences in the United Kingdom.

4.3.2 Detection of cassava hybrids using polymorphic SNP markers

The cassava-specific 514 polymorphic SNP oligonucleotides that were previously designed for KAPSar technology at KBioscience for Nachinyaya and AR37-80 were used for SNP genotyping of F₁ hybrids and the parental genotypes. After SNP genotyping, data were coded in an excel sheet under JoinMap segregation type *lm×ll* for genotypes segregating on female parent, *nn×np* for genotypes segregating in male parent; and *hk×hk* for genotypes segregation in both parents. Markers were evaluated for the purpose of excluding non-informative ones. *Chi-square* test was performed on each locus to test the deviations from expected Mendelian segregation. Markers with high segregation distortion were excluded

from analysis. Individuals were also tested according to missing data; those individuals with missing data above 10% were excluded.

The genetic linkage maps were constructed using JoinMap^(R) version 4.1 software with the following parameters as cross pollinated type; an out-breeding species full-sib family (Van Ooijen, 2011). Maternal and paternal maps were developed simultaneously with the integrated parental map in a one-step approach from the combined data set regardless of whether they segregated in one parent or both parents. The groupings of linked markers were determined using threshold level of logarithm of odds (LOD) 3 with maximum of LOD score of 10 and with a difference of LOD 1. Marker order was determined using maximum likelihood mapping and recombination frequencies were translated into map distances using the Haldane mapping function. Mapping function translates recombination frequencies between two markers into a map distance in cM. Haldane mapping function assumes no interference in recombination frequencies while; Kosambi mapping function assumes some interference. However, according to van der Werf and Kinghorn there are very little differences between the two mapping functions. In this study Haldane mapping function was used in the construction of the linkage map and little difference would be expected if Kosambi mapping function was used. The genetic linkage map in this study was then compared with the SNP map of the first SNP- based CBSD resistant study (Rabbi *et al.*, 2012) using Microsoft Access.

4.4 Results

4.4.1 Linkage mapping

Of 257 F₁ genotypes (true hybrids), 19 genotypes were excluded from the analysis because they had missing data above 10%, and finally 238 individuals were used for the construction of genetic linkage map. A total of 463 (90%) SNP markers were polymorphic and segregated with the expected genotypes. However, only 426 SNP markers were used for construction of genetic linkage maps. The segregation of genotype $lm \times ll$ on maternal parent, Nachinyaya, accounted for 44.1% while $nn \times np$ segregating for the paternal parent, AR37-80 accounted for 43.2%. A total of 12.7% segregated in both parents, $hk \times hk$. Eight SNP markers Me.MEF.c.0993, Me.MEF.c.1022, Me.MEF.c.1087, Me.MEF.c.2658, Me.MEF.c.2693, Me.MEF.c.2851, Me.MEF.c.3011 and Me.MEF.c.3070 had severe

segregation distortion based on *Chi*-square values above 162.25 ($P=0.0001$) and were excluded from the analysis.

4.4.2 Construction of genetic linkage maps

The genetic linkage map was constructed using JoinMap 4.1 software with default parameters, independent LOD started at 3.0 with maximum of 10.0 and a step of 1.0. The probability value started at $1.0e-0.4$, maximum of $1.0e-0.4$ and step of $-5.0e-0.5$. Recombination frequency was 0.250, maximum 0.050 and a step of -0.050. Finally the link LOD started at 2.0 with maximum of 10.0 and a step of 1.0. As a result of grouping markers using the independence LOD score of 3 or 4, 20 linkage groups defined initially (Figure 1). A few markers were excluded for similar reasons, such as Me.MEF.c.1307 in LG 1 increased distance to 127.3cM, but its removal reduced the distance to 101.5cM. The presence of Me.MEF.c.3025 in LG 2 caused failure to build the map because determination steps were not encountered. Therefore, this group was split into two sub-groups; one sub-group composed of markers segregating on paternal parent and the other had markers segregating on both parents. Other markers that were excluded in linkage groups during map development included Me.MEF.c.1032, Me.MEF.c.2630, Me.MEF.c.1039, Me.MEF.c.0666, Me.MEF.c.0685, Me.MEF.c.0797, Me.MEF.c.1267, Me.MEF.c.1906, Me.MEF.c.2124, Me.MEF.c.2801, Me.MEF.c.3081, Me.MEF.c.3174, Me.MEF.c.3175, Me.MEF.c.2636, Me.MEF.c.2437, Me.MEF.c.2977, Me.MEF.c.0104, Me.MEF.c.1134, Me.MEF.c.2466, Me.MEF.c.0578, Me.MEF.c.0553, Me.MEF.c.0031, Me.MEF.c.3209, Me.MEF.c.1433, Me.MEF.c.2900 and Me.MEF.c.3055. Marker Me.MEF.c.1134 and Me.MEF.c.2466 were excluded because they had weak linkages with the rest of markers in the group. Me.MEF.c.0104 was excluded because its presence caused failure map development. In general the excluded markers did not show strong evidence that they belong to a particular group.

In this study, 20 linkage groups in cassava were developed instead of 18 linkage groups. A total of 426 SNP markers were mapped generating a linkage map of 217 unique SNP loci (51%) of the total number of SNP loci mapped (Table 6) and these new markers were not evenly distributed across the twenty linkage groups. The number of new markers ranged from one (LG20) to 26 SNPs (G 8). Other linkage groups had markers ranging from 12 SNPs (LG14), 15 SNPs (LG 2 and 6), 19 SNPs (LG10), 20 SNPs (LG9) and 21 SNPs (LG7). The rest of the linkage groups had new markers ranging from one SNP to 11 SNPs.

The length of linkage map in this study was 1697 cM with an average distance between markers of 3.98 cM. The average long linkage groups were observed on LG 14 (8.3 cM) and 19 (6.3 cM), while average short linkage groups were observed on LG 15 (1.3 cM) and 18 (1.8 cM).

Most of the SNP markers were assigned to LG 1 (35), 9 (35), 6 (37) and 8 (41), with distance ranging from 92 to 159cM. However, the long LG distances were observed on LG 10 (159 cM), 9 (157 cM) and LG 14 (141 cM). Some SNP markers (Table 4) were divided into several linkage sub-groups. These include LG 2, 3, 5, 6, 9, 12 and 13 (Figure 1). The SNP markers in LG 2b, LG 3b, LG 15, LG 18 and LG 20 segregated on paternal parent; however, LG 6b, LG 12c and LG 13b segregated on maternal. SNP markers were not evenly distributed in different groups, the largest linkage group (LG 8) had 41 markers and the small linkage groups LG 19 and LG 20 had six and five SNP markers, respectively (Table 4). Finally, a SNP-based genetic linkage map was constructed with 426 SNP markers distributed across 20 linkage groups and 238 F₁hybrids using cassava genotypes spanning 1697cM (Figure 1, Table 4).

Table 3: SNP markers and distance assigned to 20 linkage groups of cassava F₁ hybrids derived from Nachinyaya × AR37-80.

Linkage group	Number of SNP markers	Total distance (cM)	Average marker distance (cM)
1	35	101	2.9
2	24	89	3.3
3	21	87	4.1
4	26	117	4.5
5	26	135	5.2
6	37	92	2.5
7	18	108	6.0
8	41	125	3.1
9	35	157	4.5
10	30	159	5.3
11	20	69	3.5
12	23	107	4.6
13	19	52	5.8
14	17	141	8.3
15	13	16	1.3
16	10	24	2.4
17	12	64	5.3
18	8	14	1.8
19	6	38	6.3
20	5	10	2.1
Total	20	426	1,697
			Average 3.98

4.5 Comparison with previous SNP and SSR genetic linkage map

Generally most linkage groups showed that more markers were mapped on hybrids than the parent Nachinyaya and AR37-80; except LG 5b. The numbers of SNP markers mapped on LG 5b are the same as those in parent AR37-80. However, SNP marker Me.MEF.c.1267, Me.MEF.c.1906 and Me.MEF.c.0685 are present in the linkage groups of both parents. The SNP-based cassava genetic linkage map in this study was compared with the previous cassava genetic linkage map constructed using a mapping population derived from variety Namikonga and Albert which consisted of 19 linkage groups, 568 markers (434 SNPs and 134 SSR markers) (Rabbi *et al.*, 2012). However, in this study, 426 SNP markers were mapped into 20 linkage groups with five SNP markers mapped to a new linkage group LG 20. Out of these five markers, four were previously mapped to LG 2-1. The new LG 20 spanned 20 cM with an average of 2 cM between two markers. In addition to these four markers, a new SNP marker Me.MEF.c.3066 was also assigned to LG 20.

Equivalent linkage groups and the SNP markers assigned to each linkage group between the two cassava maps are given in Table 5 and Table 6, where 209 markers were common to the two maps. From these, 202 markers were from the linkage maps constructed from the combined data set with all segregation types; and seven markers were from maps constructed from paternal and maternal data sets. This result showed that the 209 common SNP markers used in this study of Nachinyaya \times AR37-80 and Namikonga \times Albert were assigned to different linkage groups (Table 5) because the two populations were derived from different parental genotypes and were segregating differently.

CBSD resistance is quantitatively controlled by polygenes and different markers are assigned to different linkage groups associated with CBSR resistance (Kulembeka *et al.*, 2010). This suggests that several genes/QTLs are involved in conferring resistance to CBSR. The results from diallel analysis detected large contribution of additive gene effects in the control of CBSR resistance (Kulembeka, 2010). From this study, the SNP markers were re-assigned to different linkage groups in NCAR except those that were in LG 8. Almost all linkage groups in this study shared common SNP markers with that of NMAL linkage groups except for linkage group 19-1 and 17-1. The common markers in NCAR ranged from 2 (LG 19) to 22 (LG 6), however the new markers identified in NCAR ranged from 1 (LG 20) to 26 (LG 8). Considering the 20 linkage groups, variable assignment of SNP markers were detected in comparison with NMAL (Table 6). The most common markers were detected in

LG 6, 13, 4, 11, and 5, while the least common markers were assigned to LG 19. However no common markers in the NCAR and NMAL were observed on LG 5.

LG 1 Nachinyaya

LG 1 Both parents LG 1 AR37-80

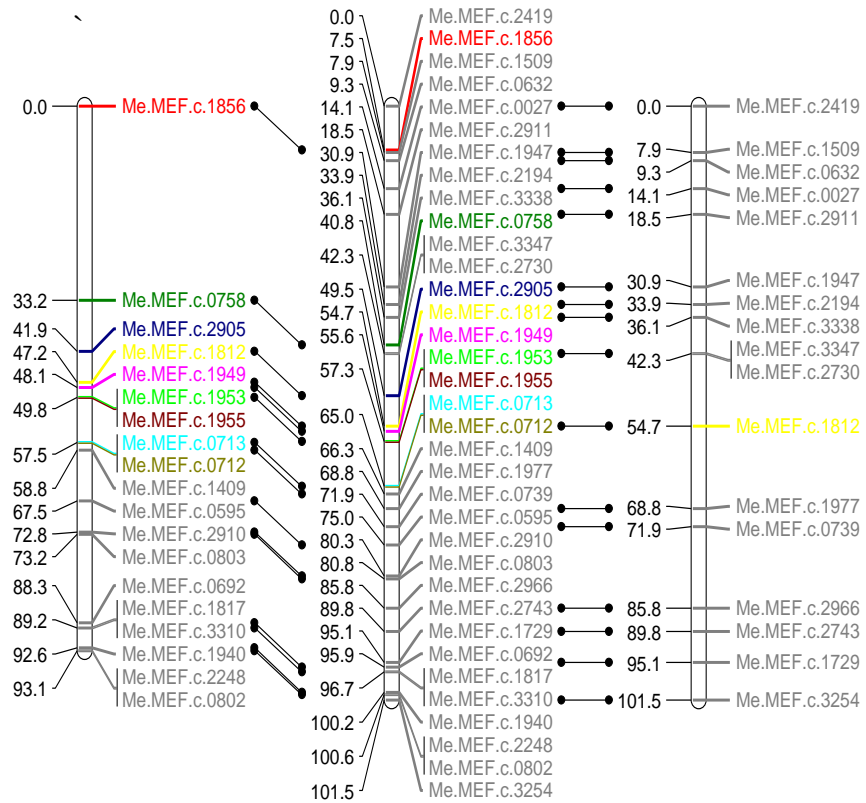

LG 2 Nachinyaya LG 2 Both parents LG 2 AR37-80

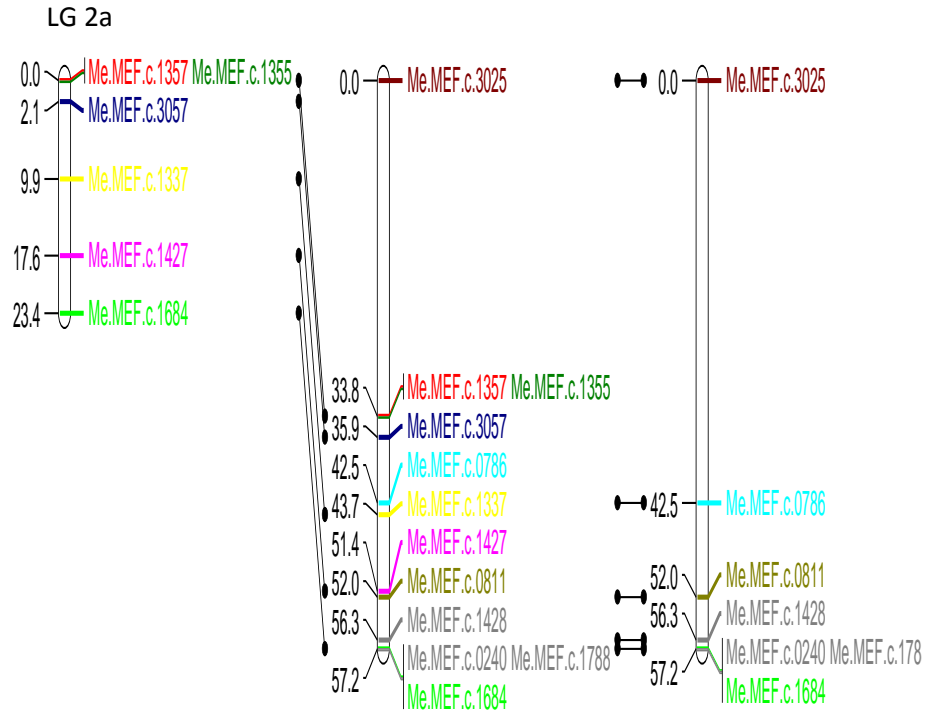

LG2b



Figure 1: SNP-based genetic linkage map of F₁ cassava (*Manihot esculenta* Crantz)

Colors in the map indicate SNP markers from parental maps to the integrated map.

LG groups with a, b or c refers to linkage groups that split into two or three sub-groups.

Nachinyaya and AR37-80 refers to female and male parents respectively.

The homologs indicate the markers shared between each parent to the integrated F₁ map.

LG 3 Nachinyaya

LG 3 Both parents

LG3 AR37-

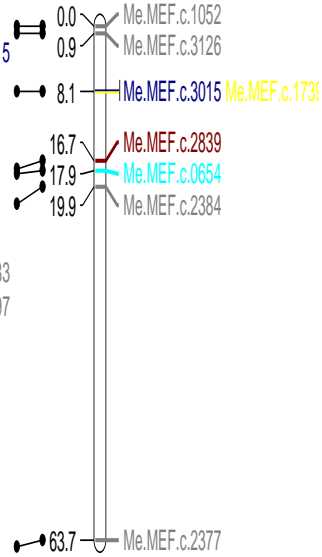
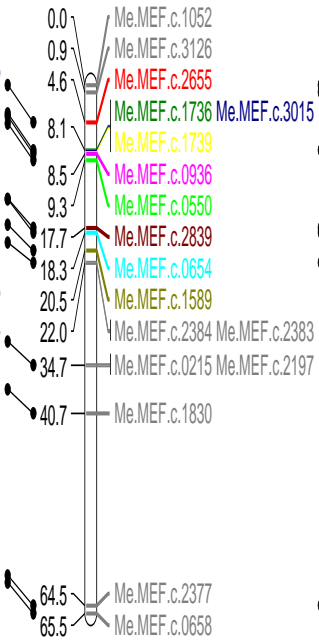
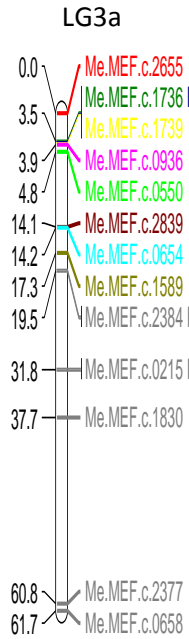

LG 4 Nachinyaya LG 4 Both parent LG4 AR37-80

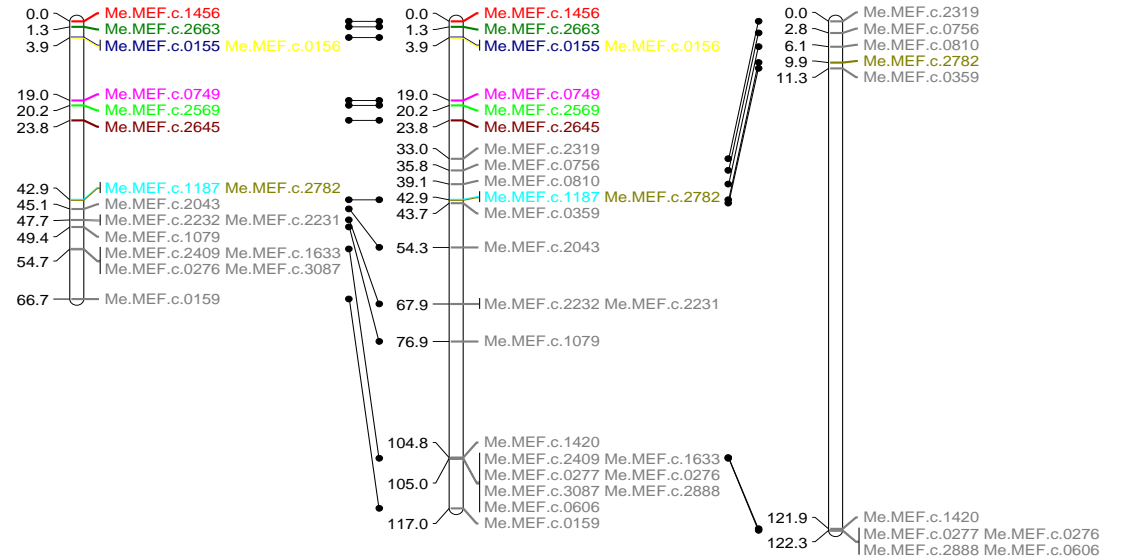

LG 3b

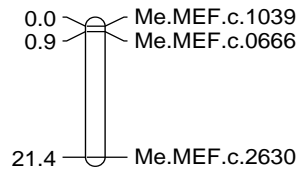

LG 5 Nachinyaya

LG 5 Both parents

LG 5 AR37-80

LG5a

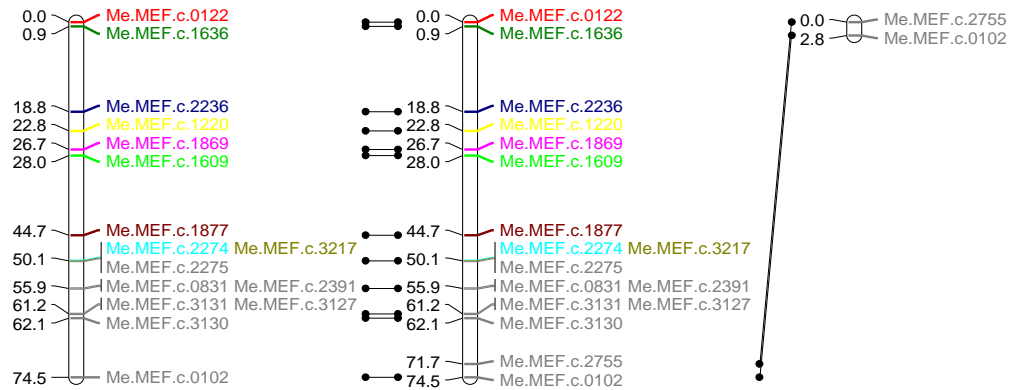

LG 5 Nachinyaya

LG 5 Both parent

LG 5 AR37-80

LG 6 Nachinyaya

LG 6 Both parent

LG 6 AR37-80

LG5b

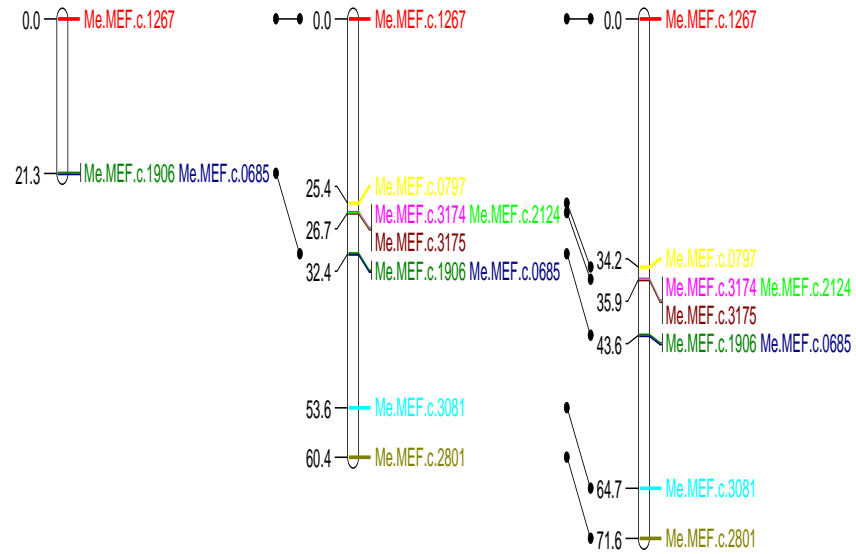

LG 6a

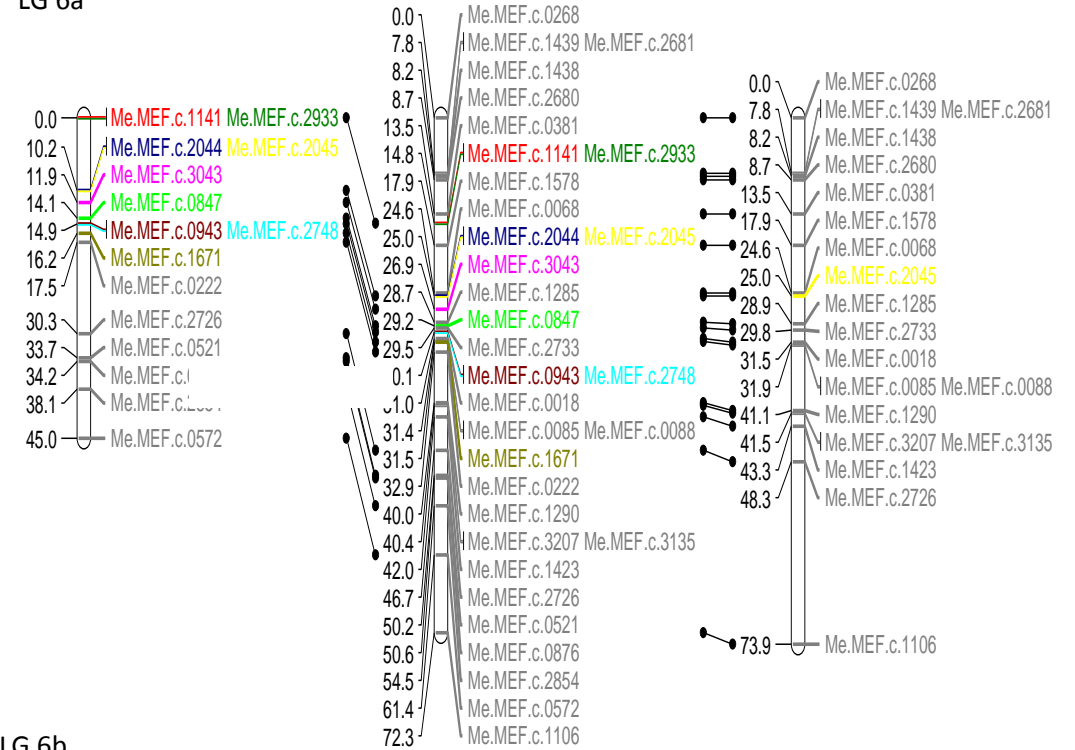

LG 6b

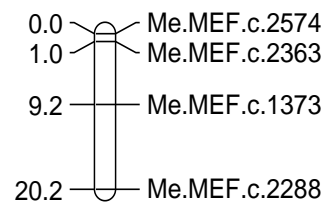

LG 7 Nachinyaya LG 7 Both parents LG 7 AR37-80

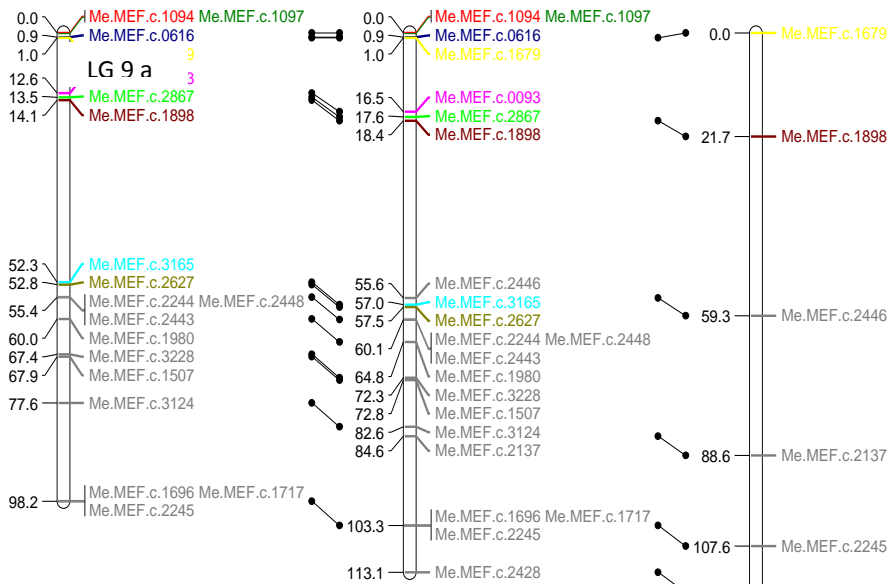

LG 9 Nachinyaya LG 9 Both parents LG 9 AR37-80

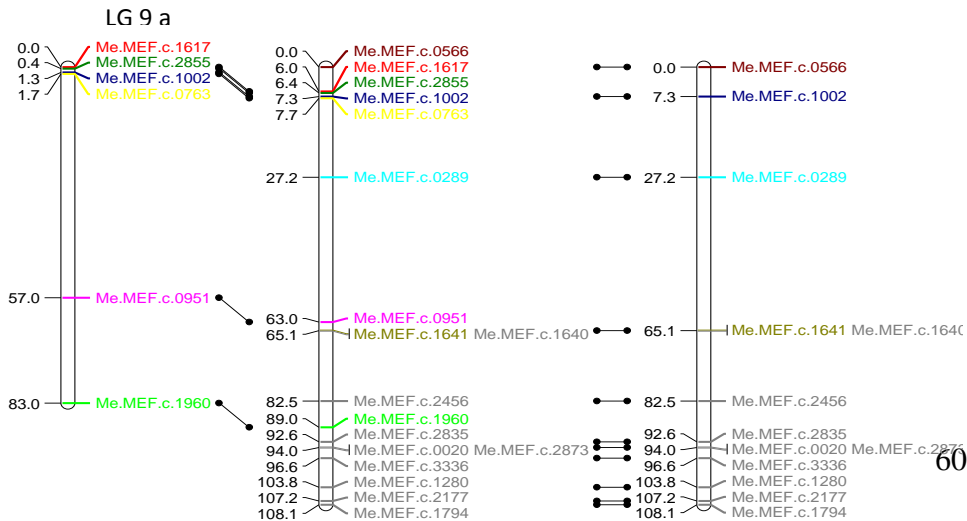

LG 8 Nachinyaya LG 8 Both parents LG 8 AR37-80

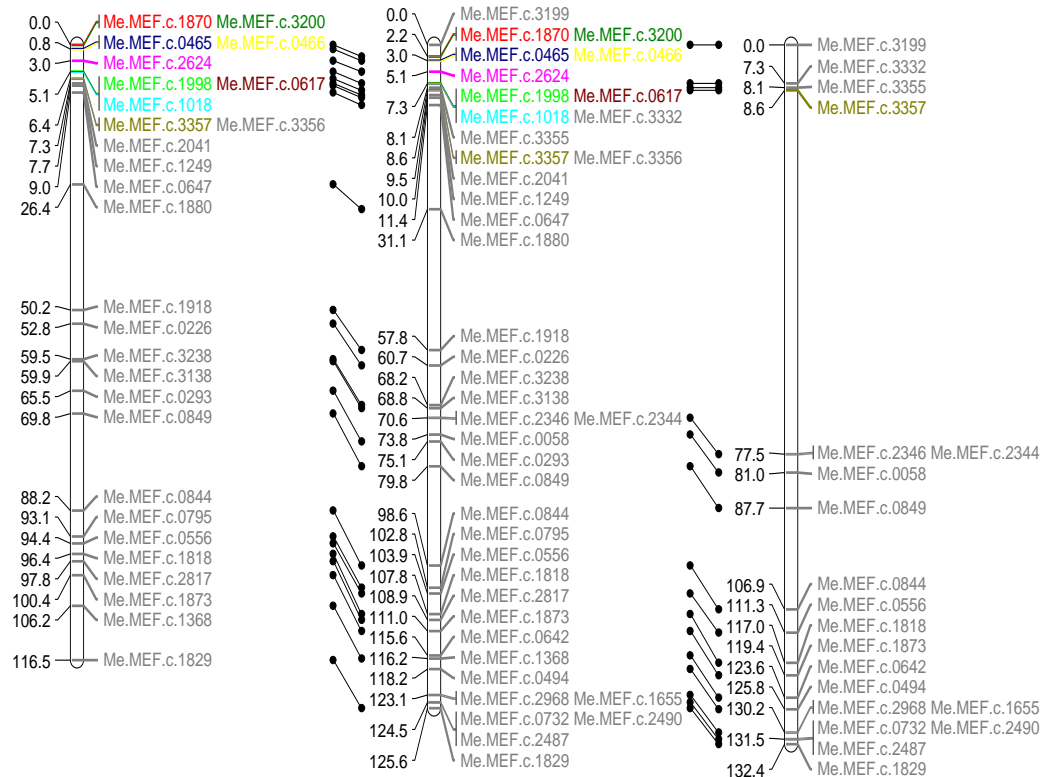

LG 9 Nachinyaya LG 9 Both parents LG 9 AR37-80

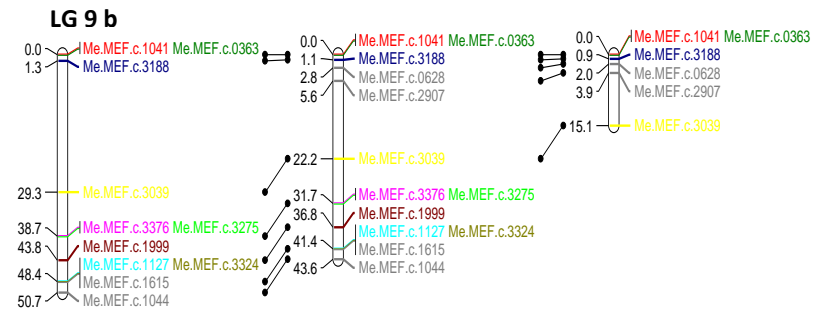

LG 10 Nachinyaya

LG 10 Both parents

LG 10 AR37-80

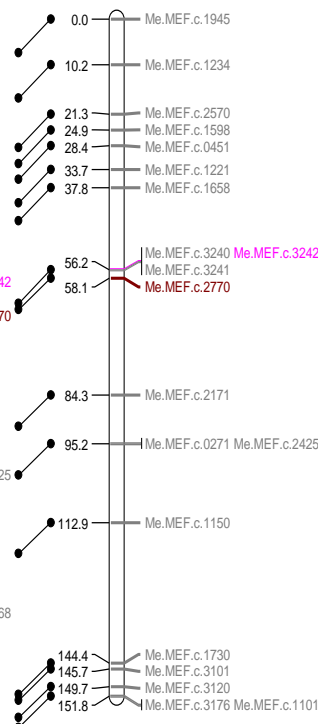
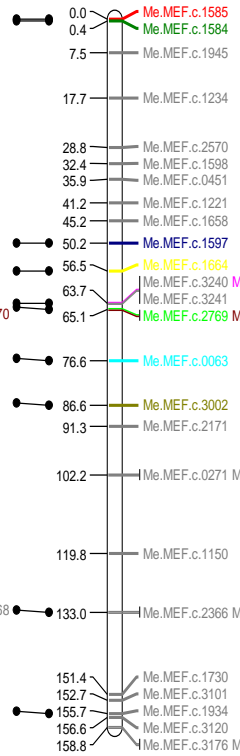
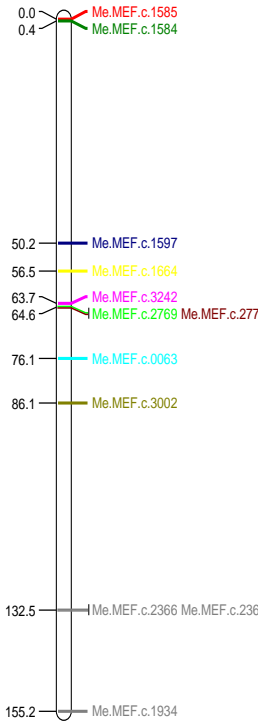

LG 11 Nachinyaya

LG 11 Both parents

LG 11 AR37-80

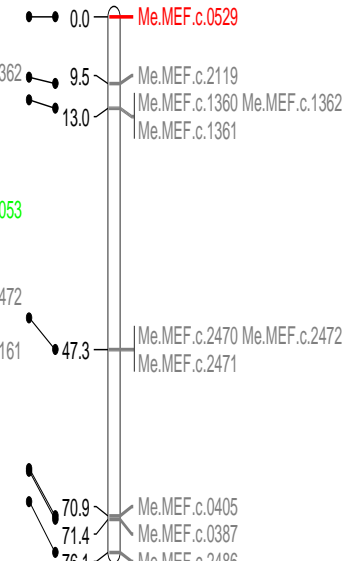
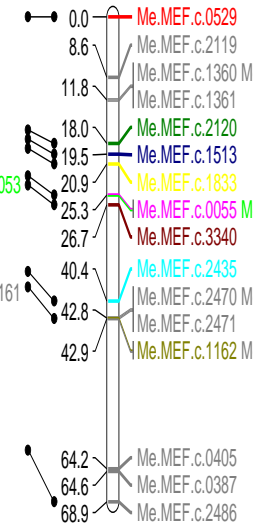
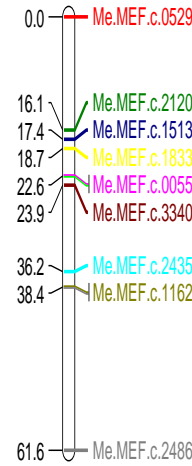

LG 12 a



LG12 Nachinyaya

LG 12 Both parents

LG 12 AR37-80

LG 12 Nachinyaya

LG 12 Both parents

LG 12 AR37-80

LG 12c

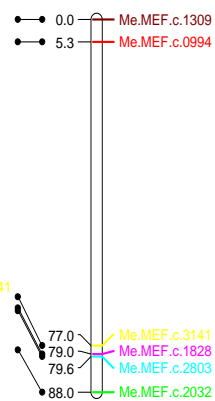
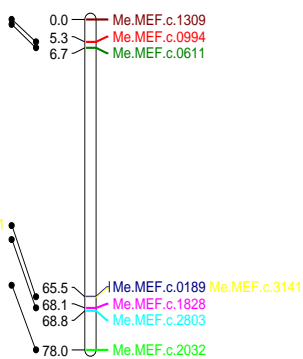
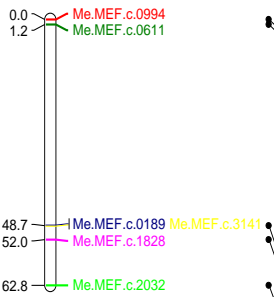

LG 12b

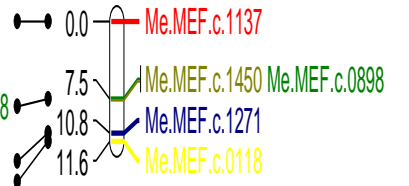
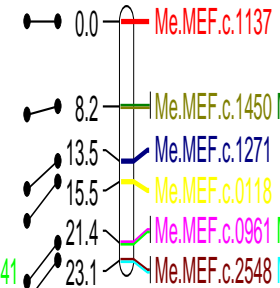
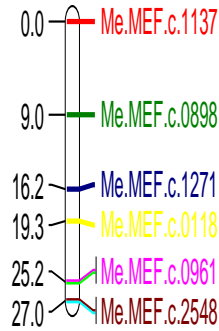

LG 13 Nachinyaya

LG 13 Both parents

LG 13 AR37-80

LG13a

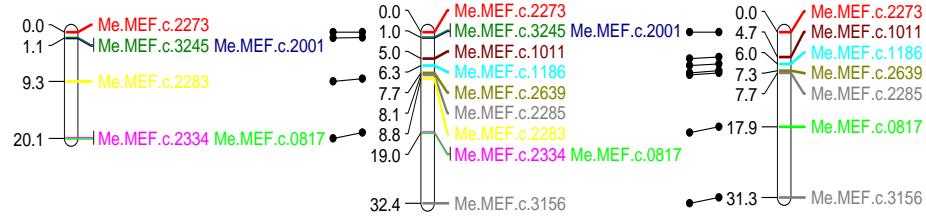

LG 13b

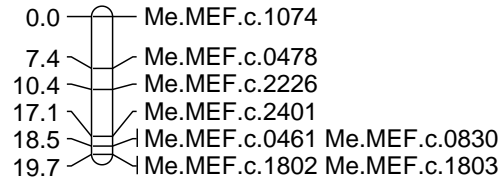

LG15

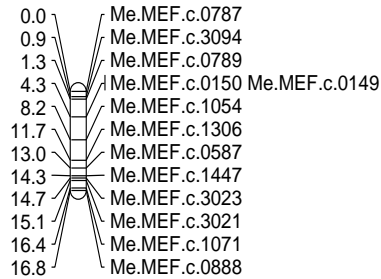

LG14 Nachinyaya

LG14 Both parents

LG14 AR37-80

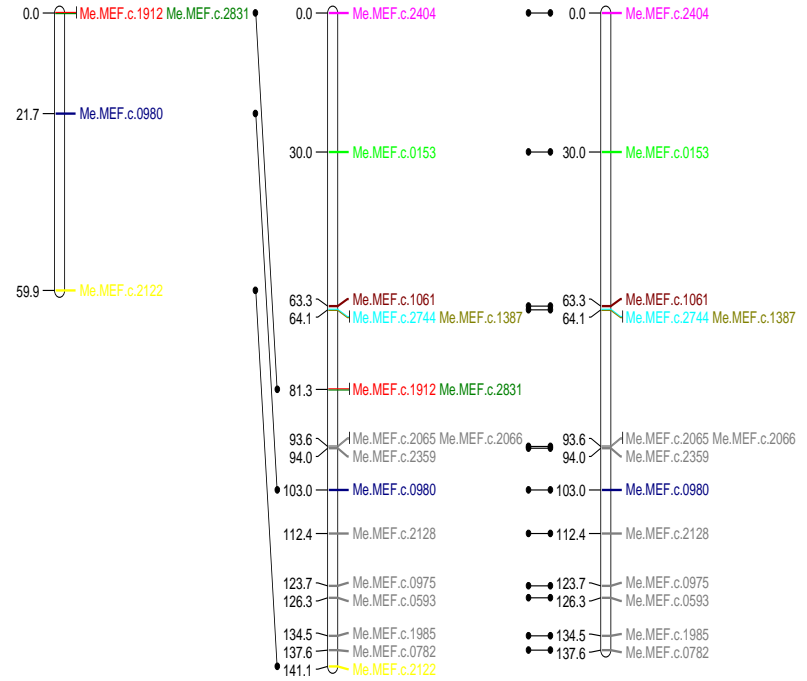

LG 16 Nachinyaya

LG 16 Both parents

LG 16 AR37-80

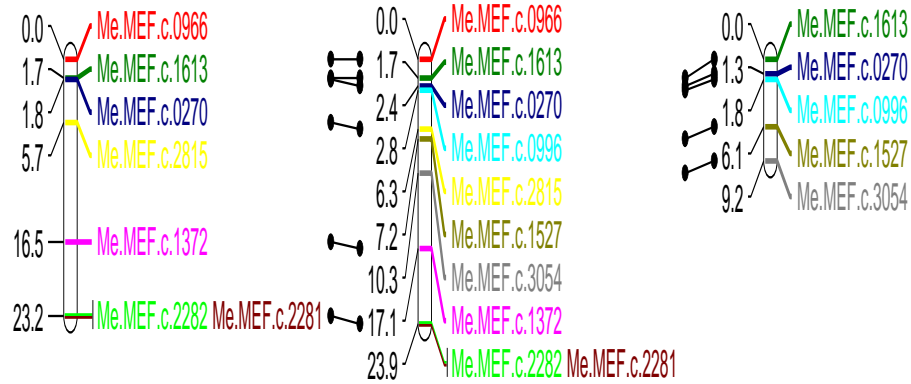

LG 17 Nachinyaya LG 17 Both parents

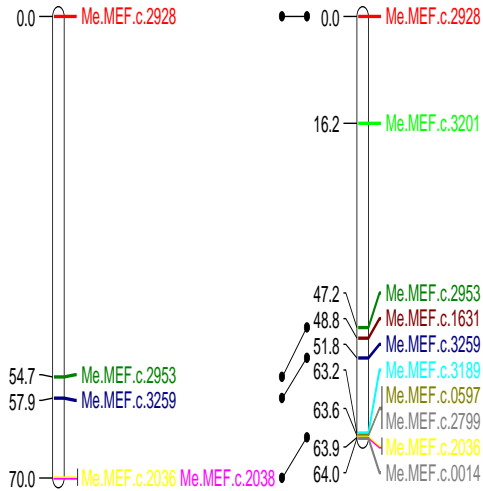

LG 17 AR37-80

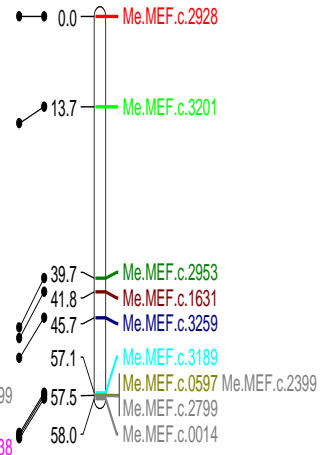

LG19 Nachinyaya LG19 Both parents LG19 AR37-80

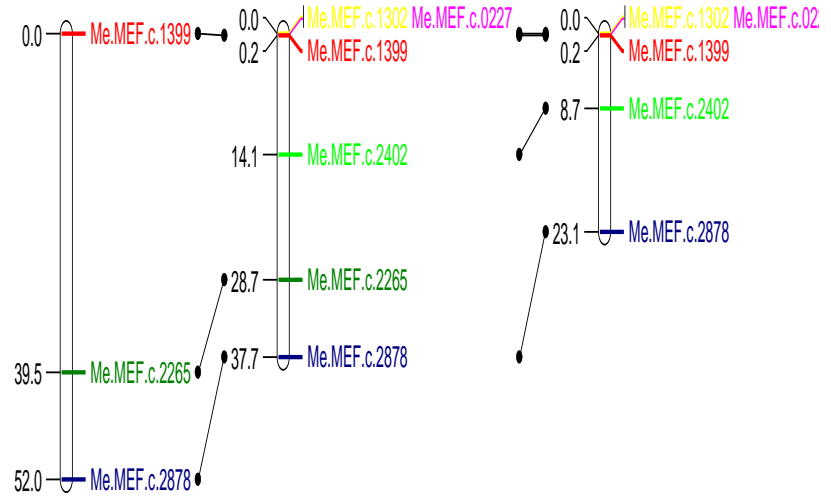

LG18

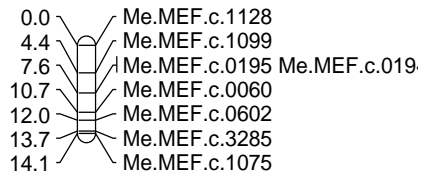

LG20

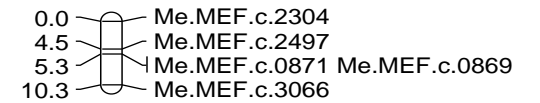

Table 4. Common SNP markers in Nachinyaya × AR37-80 map and a map of Namikonga × Albert

NMAL SNPs	NMAL LG	NCAR LG	NMAL SNPs	NMAL LG	NCAR LG	NMAL SNPs	NMAL LG	NCAR LG
Me.MEF.c. 14	16-1	17	Me.MEF.c. 405	4-1	11	Me.MEF.c.1828	10-1b	12
Me.MEF.c. 20	3-1	7	Me.MEF.c. 461	6-1	13	Me.MEF.c.1856	5-1	1
Me.MEF.c. 58	8-1	8	Me.MEF.c. 478	6-1	13	Me.MEF.c.1870	8-1	8
Me.MEF.c. 60	6-1	18	Me.MEF.c. 494	8-1	8	Me.MEF.c.1947	5-1	1
Me.MEF.c. 68	1-1	6	Me.MEF.c. 508	2-1	12	Me.MEF.c.1953	5-1	1
Me.MEF.c. 85	1-1	6	Me.MEF.c. 566	3-1	7	Me.MEF.c.1955	5-1	1
Me.MEF.c. 88	1-1	6	Me.MEF.c. 572	1-1	6	Me.MEF.c.1977	5-1	1
Me.MEF.c. 102	7-1	5	Me.MEF.c. 587	13-1	15	Me.MEF.c.1998	5-1	8
Me.MEF.c. 118	10-1a	12	Me.MEF.c. 593	12-1	14	Me.MEF.c.2032	10-1b	12
Me.MEF.c. 126	2-1	12	Me.MEF.c. 595	5-1	1	Me.MEF.c.2041	8-1	8
Me.MEF.c. 149	13-1	15	Me.MEF.c. 597	16-1	17	Me.MEF.c.2076	15-1	2
Me.MEF.c. 150	13-1	15	Me.MEF.c. 602	6-1	18	Me.MEF.c.2120	4-1	11
Me.MEF.c. 153	12-1	14	Me.MEF.c. 606	9-1	4	Me.MEF.c.2124	7-1	5
Me.MEF.c. 156	9-1	4	Me.MEF.c. 611	10-1b	12	Me.MEF.c.2137	4-1	9
Me.MEF.c. 194	6-1	18	Me.MEF.c. 617	8-1	8	Me.MEF.c.2177	3-1	7
Me.MEF.c. 195	6-1	18	Me.MEF.c. 712	5-1	1	Me.MEF.c.2194	5-1	1
Me.MEF.c. 222	1-1	6	Me.MEF.c. 713	5-1	1	Me.MEF.c.2953	16-1	17
Me.MEF.c. 226	8-1	8	Me.MEF.c. 739	5-1	1	Me.MEF.c.3002	11-1	10
Me.MEF.c. 227	18-1	19	Me.MEF.c. 749	9-1	4	Me.MEF.c.3021	13-1	15
Me.MEF.c. 268	1-1	6	Me.MEF.c. 782	12-1	14	Me.MEF.c.3023	13-1	15
Me.MEF.c. 271	11-1	10	Me.MEF.c. 786	15-1	2	Me.MEF.c.3039	14-1	9
Me.MEF.c. 276	9-1	4	Me.MEF.c. 789	13-1	15	Me.MEF.c.3043	1-1	6
Me.MEF.c. 289	3-1	7	Me.MEF.c.97	7-1	5	Me.MEF.c.3054	2-1	16
Me.MEF.c. 359	9-1	4	Me.MEF.c. 803	5-1	1	Me.MEF.c.3057	15-1	2
Me.MEF.c. 381	1-1	6	Me.MEF.c. 810	9-1	4	Me.MEF.c.3081	7-1	5
Me.MEF.c. 387	4-1	11	Me.MEF.c. 811	15-1	2	Me.MEF.c.3094	13-1	15
Me.MEF.c. 817	6-1	13	Me.MEF.c. 1360	4-1	11	Me.MEF.c.3127	7-1	5
Me.MEF.c. 830	6-1	13	Me.MEF.c. 1361	4-1	11	Me.MEF.c.3131	7-1	5
Me.MEF.c.831	7-1	5	Me.MEF.c.1362	4-1	11	Me.MEF.c.3135	1-1	6
Me.MEF.c.847	1-1	6	Me.MEF.c.1373	1-1	6	Me.MEF.c.3138	8-1	8
Me.MEF.c.869	2-1	20	Me.MEF.c.1420	9-1	4	Me.MEF.c. 3141	10-1b	12
Me.MEF.c.871	2-1	20	Me.MEF.c.1423	1-1	6	Me.MEF.c. 3142	15-1	2
Me.MEF.c.898	10-1a	12	Me.MEF.c.1450	10-1a	12	Me.MEF.c. 3156	6-1	13
Me.MEF.c.943	1-1	6	Me.MEF.c.1456	9-1	4	Me.MEF.c. 3165	4-1	9
Me.MEF.c.951	3-1	7	Me.MEF.c.1507	4-1	9	Me.MEF.c. 3174	7-1	5
Me.MEF.c.966	2-1	16	Me.MEF.c.1509	5-1	1	Me.MEF.c. 3176	11-1	10
Me.MEF.c.975	12-1	14	Me.MEF.c.1513	4-1	11	Me.MEF.c. 3189	16-1	17
Me.MEF.c.994	10-1b	12	Me.MEF.c.1527	2-1	16	Me.MEF.c. 3199	8-1	8
Me.MEF.c.996	2-1	16	Me.MEF.c.1598	11-1	10	Me.MEF.c. 3200	8-1	8
Me.MEF.c.1018	8-1	8	Me.MEF.c.1609	7-1	5	Me.MEF.c. 3201	16-1	17
Me.MEF.c.1044	14-1	9	Me.MEF.c.1615	14-1	9	Me.MEF.c. 3207	1-1	6
Me.MEF.c.1074	6-1	13	Me.MEF.c.1617	3-1	7	Me.MEF.c. 3217	7-1	5
Me.MEF.c.1097	4-1	9	Me.MEF.c.1636	7-1	5	Me.MEF.c. 3241	11-1	10
Me.MEF.c.1099	6-1	18	Me.MEF.c.1671	1-1	6	Me.MEF.c. 3242	11-1	10
Me.MEF.c.1128	6-1	18	Me.MEF.c.1679	4-1	9	Me.MEF.c. 3275	14-1	9
Me.MEF.c.1137	10-1a	12	Me.MEF.c.1696	4-1	9	Me.MEF.c. 3324	14-1	9
Me.MEF.c.1186	6-1	13	Me.MEF.c.1730	11-1	10	Me.MEF.c. 3336	3-1	7
Me.MEF.c.1187	9-1	4	Me.MEF.c.1802	6-1	13	Me.MEF.c. 3338	5-1	1
Me.MEF.c.2799	16-1	17	Me.MEF.c.2831	12-1	14	Me.MEF.c. 3347	5-1	1
Me.MEF.c.2801	7-1	5	Me.MEF.c.2835	3-1	7	Me.MEF.c. 3355	8-1	8
Me.MEF.c.2815	2-1	16	Me.MEF.c.2855	3-1	7	Me.MEF.c. 3356	8-1	8
Me.MEF.c.2821	2-1	12	Me.MEF.c.2873	3-1	7	Me.MEF.c. 3376	14-1	9
Me.MEF.c.2823	2-1	12	Me.MEF.c.2888	9-1	4	Me.MEF.c. 2910	5-1	1
Me.MEF.c.2448	4-1	9	Me.MEF.c.2548	10-1a	12	Me.MEF.c. 2639	6-1	13
Me.MEF.c.2456	3-1	7	Me.MEF.c.2549	10-1a	12	Me.MEF.c. 2645	9-1	4
Me.MEF.c.2472	4-1	11	Me.MEF.c.2570	11-1	10	Me.MEF.c. 2726	1-1	6
Me.MEF.c.2486	4-1	11	Me.MEF.c.2574	1-1	6	Me.MEF.c. 2748	1-1	6
Me.MEF.c.2497	2-1	20	Me.MEF.c.2635	15-1	2	Me.MEF.c. 2782	9-1	4
Me.MEF.c.1220	7-1	5	Me.MEF.c.2319	9-1	4	Me.MEF.c.2236	7-1	5
Me.MEF.c.1221	11-1	10	Me.MEF.c.2334	6-1	13	Me.MEF.c.2282	2-1	16
Me.MEF.c.1280	3-1	7	Me.MEF.c.2344	8-1	8	Me.MEF.c.2283	6-1	13
Me.MEF.c.1285	1-1	6	Me.MEF.c.2346	8-1	8	Me.MEF.c.2285	6-1	13
Me.MEF.c.1290	1-1	6	Me.MEF.c.2363	1-1	6	Me.MEF.c.2288	1-1	6
Me.MEF.c.1337	15-1	2	Me.MEF.c.2366	11-1	10	Me.MEF.c.2304	2-1	20
Me.MEF.c.1355	15-1	2	Me.MEF.c.2391	7-1	5	Me.MEF.c.2401	6-1	13
Me.MEF.c.1357	15-1	2	Me.MEF.c.2399	16-1	17	Me.MEF.c.2402	18-1	19
Me.MEF.c.2409	9-1	4	Me.MEF.c.2428	4-1	9	Me.MEF.c.2446	4-1	9
Me.MEF.c.2425	11-1	10						

Key: NMAL SNPs = SNP markers in Namikonga and Albert map. NMALG= Linkage groups in that map.NCAR SNPs= SNP markers in Nachinyaya×AR37-80 map; NCARGL=linkage groups in that map.

Table 5: Summary of comparison between SNP-based cassava maps in Nachinyaya × AR37-80 (NCAR) map and Namikonga × Albert (NMAL) map.

NMAL LG	NCAR LG	NCAR SNP	NMAL SNP	No. of markers in common	New markers in NCAR map	No. of markers found only in NMAL	NCAR Distance (cM)	NMAL Distance (cM)
1-1	6	37	36	22	15	14	92.5 20.2	104.9
2-1	16(6), 12(4), 20(4)	10	36	14	4	22	23.9 78 23.2 10.3	96.4
3-1	7	21	37	12	21	25	108.2	118.5
4-1	11(9), 9(9)	26	34	18	11	16	68.9 43.6	104.5
5-1	1(15), 8(1)	26	33	16	11	17	101.5	93.1
6-1	13(13), 18(6)	37	32	19	6 2	13	32.4 19.7 14.1	143.4
7-1	5	18	32	15	11	17	74.5 60.4	121.4
8-1	8	41	26	14	26	11	125.6	118.4
9-1	4	35	24	14	12	10	117	40.6
10-1a	12	30	10	6	8	4	78, 23.1	36.4
10-1b	7	7	7	5	5	2	5.6, 108.2	71.0
11-1	10	30	16	11	19	5	158.8	131.5
12-1	14	17	20	5	12	15	141.1	98.3
13-1	15	13	23	7	6	16	16.8	75.5
14-1	9	35	16	6	20	10	43.6	101.4
15-1	2	24	15	9	15	6	57.2 21.9	70.5
16-1	17	12	12	7	5	5	64.1	51.3
17-1	0	0	11	0	0	11	0	61.2
18-1	19	6	8	2	4	6	37.7	15.0
19-1	0	0	2	0	0	2	0	44.2
20	0	5	0	0	1	0	10.3	0

Key: Numbers in brackets indicates the number of SNP markers, NMAL= An F₁ hybrids derived from a cross between Namikonga × Albert; NCAR= An F₁ hybrids derived from a cross between Nachinyaya × AR37-80; cM= CentiMorgans and LG= linkage group

4.4 Discussion

This study involved two divergent and heterozygous parents basing on the tolerance and susceptibility levels to cassava brown streak disease as a major goal for mapping (Sartie and Robert, 2011). Appropriate mapping population is important and its sample size should

range from 50 to 250 *individuals* (Mohan *et al.*, 1997; Collard *et al.*, 2005) or up to 300 individuals (Kulembeka, 2010). In this study, the number of genotypes used was large enough for mapping purposes and same for high-resolution or fine mapping (Young 1994, Collard *et al.*, 2005). A mapping population size of less than 50 individuals, gives very little mapping resolution thus is not useful for map construction (Kulembeka, 2010; Sartie and Robert, 2011). High density genetic maps were developed in soybean (Hwang *et al.*, 2009), model grass (Hue *et al.*, 2011) and in common beans (Galeano *et al.*, 2012).

Various maps of cassava have been constructed predominantly using molecular markers; 119 SSR markers and 18 ESTs were distributed across 33 LGs spanned 1095 cM with an average distance of 7.99 cM average distance between two markers (Kunkeaw *et al.*, 2008). Okogbenin *et al.*, (2006), developed linkage map from F₂ cassava genotype using 100 SSR markers distributed on 22 linkage groups that spanned 1236.7 cM with an average distance of 17.92 cM between the markers. In contrast, Xia *et al.*, (2010), constructed linkage map of cassava using 355 molecular markers (AFLP, SSRs, SRAPs and EST) and were distributed across 18 linkage groups and spanned 1,707 cM. In this experiment, 257 F₁ individuals derived from Nachinyaya × AR37-80 were genotyped using 514 SNP markers. Some linkage groups were split into sub-groups because their presence increased the map distance. It was not possible to determine the phase between two groups or there were no determination steps encountered during map construction. This resulted in a map consisting of 426 SNP markers distributed on 20 linkage groups spanning 1697cM and the average distance of 3.98 between markers. The variations of linkage groups detected in this study could be attributed to different parents parental stocks and mapping population used to develop linkage maps.

Cassava has a chromosome compliment of 18 and thus we expect 18 linkage groups, which would correspond to the chromosomes. Two pairs of linkage groups in our map should merge, although due to lack of recombination events or lack of markers in a particular region of genome we do not have sufficient information on recombination events to join these groups. In addition six linkage groups were split into two sub-groups, LG 2, LG 3, LG 5, LG 6, LG 9 and LG 13, however, linkage group 12 was split into three sub-groups. Probably, sub-groups may fit with other groups but this study has no evidence to support this hypothesis.

The genetic linkage map in this study was compared with a map constructed using an F₁ population from Namikonga and Albert (Rabbi *et al.*, 2012), and 434 SNPs and 134 SSR markers. Of these, 209 SNP markers were common between the two populations (Table 2 and Table 3). There was high polymorphism between the two parents indicating high recombination frequency during meiosis resulting in mapping of 217 SNP markers mapped for the first time (Table4). It is also evident that 224 SNP markers mapped in NMAL cassava F₁ were not assigned to any linkage groups in NCAR map. The differences observed in this study could be due to the differences in segregation pattern between the parents in the mapping population and variation in polymorphic nature of the markers used. Linkage maps are unique and are products of mapping population derived from specific parents depending on the study objectives and type of markers used. The correlation of information from one map to another requires common markers (Collard *et al.*, 2005). In this study although it is hypothesized that the LG 20 existed with four SNP markers reassigned from LG 2 and a new marker, this could be attributed to differences in mapping population used. It is therefore necessary to use diverse cassava parents in developing several mapping population. In this study 80% of markers in LG 20 were previously assigned to LG2-1 in NMAL (Rabbi *et al.*, 2012). Of the SNP markers allocated to LG2, 35.7% these markers were previously mapped in LG 15-1. This shows that the redistribution of cassava SNP markers seems to depend on the parental stocks used to develop the mapping population.

The common SNP markers between the two genetic linkage maps ranged from 26% (LG 9 in NCAR genetic map) to 83.3% (LG 5 in NCAR genetic map). 55% of the linkage groups in NCAR genetic map had common markers with NMAL genetic map. However, four linkage groups in NCAR genetic map consisted of the highest common markers, LG18 (75%), LG 20 (80%), LG7 (81%) and LG 5 (83.3%). The difference in linkage group observed in this study could be due to the differences in parents used to develop mapping population. In this case the hybrids were used for development of linkage groups.

4.5 Conclusions

In this study several SNP markers were assigned to different linkage groups. Some of the markers were re-assigned to different linkage groups compared to previously developed linkage groups which used SNP markers but anchored on SSR markers (Rabbi *et al.*, 2012). In addition, a new linkage group 20 was developed with SNP marker Me.MEF.c.2304, Me.MEF.c.2497, Me.MEF.0871, Me.MEF.c.0869 reassigned from LG2-1. Lastly, new SNP

marker Me.MEF.c.3066 was also assigned to the LG20. This will lead to applications in marker-assisted breeding. In addition the new 217 SNP markers mapped will assist in the alignment of the cassava genome sequence.

4.6 Recommendations

The parents that were used to develop hybrids were not inbred lines. Therefore, it's recommended that future linkage mapping and QTL analysis, uses inbred cassava lines, despite the fact that the process may take long time. Additionally from this study, cassava hybrids that were used to construct linkage map were not phenotyped. Consequently, it would be necessary to phenotype the hybrids in order to identify QTL(s) associated with resistance to cassava brown streak disease. The map from this study could be useful in the combining development of integrated map in combination with other published cassava maps.

4.7 References

- Aslam, M.L., Bastiaansen, J.W.M., Crooijmans, R.P.M.A., Vereijken, A., Hendrik-Jan, Megens H. and Groenen. M.A.M. 2010. A SNP based linkage map of the turkey genome reveals multiple intrachromosomal rearrangements between the Turkey and Chicken genomes. *BMC Genomics*,11:647.
- Esteras, C., Gomez, P., Monforte, A.J., Jose., Blanca, J., Vicente-Dolera, N., Cristina., Roig, C., Nuez, F., Pico, B. 2012. High-throughput SNP genotyping in *Curcubita pepo* for map construction and quantitative trait loci mapping. *BMC Genomic.*, 13:80.
- Dekkers, J.C.M. 2003. Commercial applications of marker-gene-assisted selection in livestock: strategies and lessons. Paper presented at the 54th annual meeting of the European Association for Animal Production, Rome, Italy.
- FAO. 2003. "Molecular marker assisted selection as a potential tool for genetic improvement of crops, forest trees, livestock and fish in developing countries".
- Ferguson, M.E., Harne, S.J., Close, T.J., Wanamaker, S., Moskal, W.A., Town C.D., de Young J, Marri P.R., Rabbi, I.Y., de Villiers, E.P. 2011. Identification, validation and high-throughput genotyping of transcribed gene SNPs in cassava. *Theor. Appl. Genet.* 124: 685-695.
- Galeano, C.H., Cortes, A., Fernandez, A.C., Solar, A., Franco-Herrera, N., Makunde, G., Van derleyden, J. and Blair, M.W. 2012. Gene-based single nucleotide polymorphism markers for genetic and association mapping in common beans. *BMC Genetics.* 13:48.
- Hue, N., Garvin, D.F., Yu, F.M., McMahon, S., Lou, M.C., Go, Y.Q., Lazo, G.R., Vogel, J.P. 2011. Comparison of a high-density genetic linkage map to genome features in the model grass *Brachypodium distachyon*. *Theor. Appl. Genet.* 123:455-464.
- Hwang, T.Y., Sayama, T., Takahashi, M., Takada, Y., Nakamoto, Y., Funatsuki, H., hisano, H., Sasamoto, S., Sato, S., Tabata, S., Kono, I., Hoshi, M., Hanawa, M., Yano, C., Xia, Z., harada, K., Kitamura, K., Ishimoto, M. 2009. High-density integrated linkage map based on SSR markers in soybean. *DNA Research.PMC.* 16:213–225.
- Hyten, D.L., Canon, S.B., Song, Q., Weeks, N., Edward, W., Fickus, E.W., Soemaker, R.C., Specht, J.E., Andrew, A.D. and Cregan, P.B. 2010. High-throughput SNP discovery through deep re-sequencing of reduced representation library, to anchor and orient scaffolds in soybean whole genome sequence. *BMC Genomics.* 11:38.

- Kulembeka, H. P. K. 2010. Genetic linkage mapping of field resistance to cassava brown streak disease in cassava (*Manihot esculenta* Crantz) landraces from Tanzania. PhD, Thesis. University of the Free State. Bloemfontein, South Africa.
- Liu, F., Kitashiba, H., Inaba, K., Nishio, T. 2009. A *Brassica rapa* linkage map of EST-based SNP markers for identification of candidate genes controlling flowering time and leaf morphological traits. *DNA Research. PMC*. 16:311–323.
- Liu T., Li L., Zhang Y., Xu C., Li X. and Xing Y. 2011 Comparison of quantitative trait loci for rice yield, panicle length and spikelet density across three connected populations. *J. Genet.* 90: 377–382.
- Nguyen, V.T., Vuong, T.D., Van Toai, T., Lee, J.D., Wu, X., Roufman, M.A., Dorrance, A.E., Shannon, J.G. and Nuyen, H. 2012. Mapping quantitative trait loci associated with resistance to *Phytophthora sojae* and flooding tolerance in soybean. *Crop Science*. 52:2481-2493.
- Mllinarri, M., Margarido, G.R.A., Vencovsky, R .and Garcia, A.A.F. 2009. Evaluation of algorithms used to order markers on genetic map. *Heredity*. 103:494-502.
- Morgante, M., Salamini, F. (2003). From plant genomics to breeding practice. *Current Opinion Biotechnology*. 14: 214–219.
- Rabbi, I.Y., Kulembeka, H.P., Masumba, E., Marri, P.R., Ferguson M. 2012. An EST-derived SNP and SSR genetic linkage map of cassava (*Manihot esculenta* Crantz). *Theor Appl. Genet.*
- Ren, Y., Zhang, Z., Liu, J., Staub, J.E., Han, Y., Cheng, Z., Li, X, Lu, J., Miao, H., Kang, H., Xie, B., Gu, X., Wang, X., Du, Y., Jin, W., Huang, S. 2009. An integrated genetic and cytogenetic map of the cucumber genome. *PloS One*. 4:e5795.
- Sartie, A. and Robert, A. 2011. Development of mapping population for genetic analysis in yams (*Dioscorea rotundata* Poir and *Dioscorea alata*. L). *African Journal of Biotechnolgy*. 10:3040-3050.
- Syvanen, A.C. 2001 Accessing genetic variation: genotyping single nucleotide polymorphisms. *Nat. Rev. Genet.* 2:930-42
- McCouch, S. R., Zhao, K., Wright, M., Tung, C., Eban, K., Thomson, M., Reynolds, A., Wang, D., DeClerck, G., Liakat, M.A., McClung, A., Eizenga, G. and Bustamante, C. 2010. Development of genome-wide SNP assays for rice. *Breeding Science*. 60: 524-535.

- Troggio, M., Malacarne, G., Coppola, G., Segala, C., Dustin, A., Cartwright, D.A., [Pindo, M.](#)<http://www.genetics.org/content/176/4/2637.full-target-1>, Stefanini, M., Mark, R., Marco, M., Moroldo, M., Morgante, M., M. Stella, Grando, M.<http://www.genetics.org/content/176/4/2637.full-target-1> and Velasco, R. 2007. A dense Single-Nucleotide Polymorphism-based genetic linkage map of Grapevine (*Vitis vinifera* L.). Anchoring Pinot noir bacterial artificial chromosome contigs. *Genetics*, 176: 2637-2650.
- Van, Ooijen, J.W. 2011. JoinMap® 4.1, software for the calculation of genetic linkage maps in experimental populations. Kyazma B.V, Wageningen, Netherlands.
- Wang W.Y.S., Barratt, B.J., Clayton, D.G., Todd, J.A. 2005. Genome-wide association studies: theoretical and practical concerns. *Nature Reviews Genetics*, 6:10–118.
- Wang, C.M., Bai, Z.Y., He, X.P., Lin, G., Xia, J.H., Sun, F., Lo, L.C., Feng, F., Zhu, Z.Y., Yue, G.H. 2011. A high-resolution linkage map for comparative genome analysis and QTL fine mapping in Asian seabass, *Lates calcarifer*. *BMC Genomics*. 12:174.
- Wang, C.M., Liu, P., Yi, C., Gu, K., Sun, F., Li, L., Lo, L.C., Liu, X., Feng, F., Lin, C., Cao, S., Hong, Y., Yin, Z., Yue, G.H. 2011. A First Generation Microsatellite- and SNP-Based Linkage Map of *Jatropha*. *Jatropha*. PLoS ONE. 6:e23632.
- Wu, J., Jenkins, J., Zhu, J., McCanty, J., Watson, C. 2003. Monte carlo simulations on marker grouping and ordering. *Theor. App. Genet.* 107:568-573.
- Xia, J.H., Feng, L., Zhu, Z.Y., Fu, J.J., Feng, J.B., *et al.* 2010. A consensus linkage map of the grass carp (*Ctenopharyngodon idella*) based on microsatellites and SNPs. *BMC Genomics* 11:356.
- Yang, K and Jeong, S. 2008. Genetic linkage map of the nucleolus organizer region in the soybean. *Genetics society of America*, 178:605-608.
- http://www-personal.une.edu.au/~jvanderw/Introduction_and_principles_of_linkage_analysis.pdf

Appendix 1: Linkage groups and SNP marker positions

Linkage group	SNP Markers	Distance in cM	Linkage group	SNP Markers	Distance in cM
1	Me.MEF.c.2419	0.000	1	Me.MEF.c.2743	89.786
1	Me.MEF.c.1856	7.548	1	Me.MEF.c.1729	95.105
1	Me.MEF.c.1509	7.877	1	Me.MEF.c.0692	95.851
1	Me.MEF.c.0632	9.285	1	Me.MEF.c.1817	96.698
1	Me.MEF.c.0027	14.137	1	Me.MEF.c.3310	96.698
1	Me.MEF.c.2911	18.535	1	Me.MEF.c.1940	100.178
1	Me.MEF.c.1947	30.877	1	Me.MEF.c.2248	100.6
1	Me.MEF.c.2194	33.913	1	Me.MEF.c.0802	100.6
1	Me.MEF.c.3338	36.062	1	Me.MEF.c.3254	101.487
1	Me.MEF.c.0758	40.752	2	Me.MEF.c.3025	0.000
1	Me.MEF.c.2905	49.452	2	Me.MEF.c.3057	35.926
1	Me.MEF.c.1812	54.748	2	Me.MEF.c.0786	42.468
1	Me.MEF.c.1949	55.619	2	Me.MEF.c.1337	43.65
1	Me.MEF.c.1953	57.329	2	Me.MEF.c.1427	51.38
1	Me.MEF.c.1955	57.329	2	Me.MEF.c.0811	51.957
1	Me.MEF.c.0713	65.036	2	Me.MEF.c.1428	56.346
1	Me.MEF.c.0712	65.036	2	Me.MEF.c.0240	57.193
1	Me.MEF.c.1409	66.315	2	Me.MEF.c.1788	57.193
1	Me.MEF.c.1977	68.822	2	Me.MEF.c.1684	57.197
1	Me.MEF.c.0735	71.863	2	Me.MEF.c.0445	0.000
1	Me.MEF.c.0595	75.02	2	Me.MEF.c.0634	5.284
1	Me.MEF.c.2966	85.842	2	Me.MEF.c.1291	8.764
2	Me.MEF.c.3088	10.910	3	Me.MEF.c.0658	65.484
2	Me.MEF.c.2785	10.910	4	Me.MEF.c.1456	0.000
2	Me.MEF.c.3142	17.299	4	Me.MEF.c.2663	1.279
2	Me.MEF.c.3360	20.669	4	Me.MEF.c.0155	3.866
2	Me.MEF.c.0570	21.516	4	Me.MEF.c.0156	3.866
2	Me.MEF.c.1799	21.516	4	Me.MEF.c.0749	18.958
2	Me.MEF.c.2529	21.938	4	Me.MEF.c.2569	20.237
3	Me.MEF.c.1039	0.000	4	Me.MEF.c.2645	23.788
3	Me.MEF.c.0666	0.909	4	Me.MEF.c.2319	33.037
3	Me.MEF.c.2630	21.355	4	Me.MEF.c.0756	35.847
3	Me.MEF.c.1052	0.000	4	Me.MEF.c.0810	39.14
3	Me.MEF.c.3126	0.871	4	Me.MEF.c.1187	42.93
3	Me.MEF.c.2655	4.564	4	Me.MEF.c.2782	42.93
3	Me.MEF.c.1736	8.091	4	Me.MEF.c.0359	43.728

Appendix1. Continued

Linkage group	SNP Markers	Distance in cM	Linkage group	SNP Markers	Distance in cM
3	Me.MEF.c.3015	8.091	4	Me.MEF.c.2043	54.258
3	Me.MEF.c.1739	8.091	4	Me.MEF.c.2232	67.912
3	Me.MEF.c.0936	8.474	4	Me.MEF.c.2231	67.912
3	Me.MEF.c.0550	9.275	4	Me.MEF.c.1079	76.948
3	Me.MEF.c.2839	17.67	4	Me.MEF.c.1420	104.779
3	Me.MEF.c.0654	18.314	4	Me.MEF.c.2409	105.013
3	Me.MEF.c.1589	20.495	4	Me.MEF.c.1633	105.013
3	Me.MEF.c.2384	21.993	4	Me.MEF.c.0277	105.013
3	Me.MEF.c.2383	21.993	4	Me.MEF.c.0276	105.013
3	Me.MEF.c.0215	34.695	4	Me.MEF.c.3087	105.013
3	Me.MEF.c.2197	34.695	4	Me.MEF.c.2888	105.013
3	Me.MEF.c.1830	40.738	4	Me.MEF.c.0606	105.013
5	Me.MEF.c.0122	0.000	6	Me.MEF.c.0268	0.000
5	Me.MEF.c.1636	0.854	6	Me.MEF.c.1439	7.779
5	Me.MEF.c.2236	18.772	6	Me.MEF.c.2681	7.779
5	Me.MEF.c.1220	22.786	6	Me.MEF.c.1438	8.201
5	Me.MEF.c.1869	26.718	6	Me.MEF.c.2680	8.688
5	Me.MEF.c.1609	27.995	6	Me.MEF.c.0381	13.466
5	Me.MEF.c.1877	44.712	6	Me.MEF.c.1141	14.787
5	Me.MEF.c.2274	50.139	6	Me.MEF.c.2933	14.787
5	Me.MEF.c.3217	50.139	6	Me.MEF.c.1578	17.855
5	Me.MEF.c.2275	50.139	6	Me.MEF.c.0068	24.592
5	Me.MEF.c.0831	55.924	6	Me.MEF.c.2044	25.007
5	Me.MEF.c.2391	55.924	6	Me.MEF.c.2045	25.014
5	Me.MEF.c.3131	61.238	6	Me.MEF.c.3043	26.855
5	Me.MEF.c.3127	61.238	6	Me.MEF.c.1285	28.671
5	Me.MEF.c.3130	62.086	6	Me.MEF.c.0847	29.176
5	Me.MEF.c.2755	71.691	6	Me.MEF.c.2733	29.459
5	Me.MEF.c.0102	74.493	6	Me.MEF.c.0943	30.092
5	Me.MEF.c.1267	0.000	6	Me.MEF.c.2748	30.092
5	Me.MEF.c.0797	25.417	6	Me.MEF.c.0018	31.049
5	Me.MEF.c.3174	26.713	6	Me.MEF.c.0085	31.441
5	Me.MEF.c.2124	26.713	6	Me.MEF.c.0088	31.441
5	Me.MEF.c.3175	26.713	6	Me.MEF.c.1671	31.473
5	Me.MEF.c.1906	32.447	6	Me.MEF.c.0222	32.853
5	Me.MEF.c.0685	32.447	6	Me.MEF.c.1290	39.998
5	Me.MEF.c.3081	53.578	6	Me.MEF.c.3207	40.391
5	Me.MEF.c.2801	60.42	6	Me.MEF.c.3135	40.391
6	Me.MEF.c.1423	41.981	7	Me.MEF.c.1280	103.798
6	Me.MEF.c.2726	46.716	7	Me.MEF.c.2177	107.183
6	Me.MEF.c.0521	50.166	7	Me.MEF.c.1794	108.129
6	Me.MEF.c.0876	50.588	8	Me.MEF.c.3199	0.000
6	Me.MEF.c.2854	54.52	8	Me.MEF.c.1870	2.154
6	Me.MEF.c.0572	61.423	8	Me.MEF.c.3200	2.154

Appendix1. Continued

Linkage group	SNP Markers	Distance in cM	Linkage group	SNP Markers	Distance in cM
6	Me.MEF.c.1106	72.257	8	Me.MEF.c.0465	3.002
6	Me.MEF.c.2574	0.000	8	Me.MEF.c.0466	3.002
6	Me.MEF.c.2363	1.006	8	Me.MEF.c.2624	5.148
6	Me.MEF.c.1373	9.213	8	Me.MEF.c.1998	7.294
6	Me.MEF.c.2288	20.166	8	Me.MEF.c.0617	7.294
7	Me.MEF.c.0566	0.000	8	Me.MEF.c.1018	7.294
7	Me.MEF.c.1617	5.955	8	Me.MEF.c.3332	7.297
7	Me.MEF.c.2855	6.392	8	Me.MEF.c.3355	8.147
7	Me.MEF.c.1002	7.256	8	Me.MEF.c.3357	8.571
7	Me.MEF.c.0763	7.684	8	Me.MEF.c.3356	8.576
7	Me.MEF.c.0289	27.242	8	Me.MEF.c.2041	9.524
7	Me.MEF.c.0951	62.978	8	Me.MEF.c.1249	9.999
7	Me.MEF.c.1641	65.065	8	Me.MEF.c.0647	11.439
7	Me.MEF.c.1640	65.065	8	Me.MEF.c.1880	31.07
7	Me.MEF.c.2456	82.498	8	Me.MEF.c.1918	57.751
7	Me.MEF.c.1960	88.962	8	Me.MEF.c.0226	60.719
7	Me.MEF.c.2835	92.601	8	Me.MEF.c.3238	68.217
7	Me.MEF.c.0020	93.989	8	Me.MEF.c.3138	68.765
7	Me.MEF.c.2873	93.989	8	Me.MEF.c.2346	70.606
7	Me.MEF.c.3336	96.589	8	Me.MEF.c.2344	70.606
8	Me.MEF.c.0058	73.763	9	Me.MEF.c.3165	57.045
8	Me.MEF.c.0293	75.061	9	Me.MEF.c.2627	57.473
8	Me.MEF.c.0849	79.81	9	Me.MEF.c.2244	60.129
8	Me.MEF.c.0844	98.615	9	Me.MEF.c.2448	60.129
8	Me.MEF.c.0795	102.816	9	Me.MEF.c.2443	60.129
8	Me.MEF.c.0556	103.918	9	Me.MEF.c.1980	64.751
8	Me.MEF.c.1818	107.806	9	Me.MEF.c.3228	72.296
8	Me.MEF.c.2817	108.895	9	Me.MEF.c.1507	72.763
8	Me.MEF.c.1873	110.963	9	Me.MEF.c.3124	82.604
8	Me.MEF.c.0642	115.617	9	Me.MEF.c.2137	84.587
8	Me.MEF.c.1368	116.202	9	Me.MEF.c.1696	103.341
8	Me.MEF.c.0494	118.151	9	Me.MEF.c.1717	103.341
8	Me.MEF.c.2968	123.063	9	Me.MEF.c.2245	103.341
8	Me.MEF.c.1655	123.063	9	Me.MEF.c.2428	113.128
8	Me.MEF.c.0732	124.492	9	Me.MEF.c.1041	0.000
8	Me.MEF.c.2490	124.492	9	Me.MEF.c.0363	0.000
8	Me.MEF.c.2487	124.492	9	Me.MEF.c.3188	1.083
8	Me.MEF.c.1829	125.558	9	Me.MEF.c.0628	2.81
9	Me.MEF.c.1094	0.000	9	Me.MEF.c.2907	5.573
9	Me.MEF.c.1097	0.000	9	Me.MEF.c.3039	22.188
9	Me.MEF.c.0616	0.865	9	Me.MEF.c.3376	31.664
9	Me.MEF.c.1679	0.961	9	Me.MEF.c.3275	31.664
9	Me.MEF.c.0093	16.46	9	Me.MEF.c.1999	36.762
9	Me.MEF.c.2867	17.586	9	Me.MEF.c.1127	41.369
9	Me.MEF.c.1898	18.392	9	Me.MEF.c.3324	41.369
9	Me.MEF.c.2446	55.55	9	Me.MEF.c.1615	41.369

Appendix1. Continued

Linkage group	SNP Markers	Distance in cM	Linkage group	SNP Markers	Distance in cM
9	Me.MEF.c.1044	43.594	10	Me.MEF.c.3101	152.686
10	Me.MEF.c.1585	0.000	10	Me.MEF.c.1934	155.714
10	Me.MEF.c.1584	0.428	10	Me.MEF.c.3120	156.618
10	Me.MEF.c.1945	7.485	10	Me.MEF.c.3176	158.764
10	Me.MEF.c.1234	17.685	10	Me.MEF.c.1101	158.764
10	Me.MEF.c.2570	28.821	11	Me.MEF.c.0529	0.000
10	Me.MEF.c.1598	32.42	11	Me.MEF.c.2119	8.627
10	Me.MEF.c.0451	35.9	11	Me.MEF.c.1360	11.775
10	Me.MEF.c.1221	41.214	11	Me.MEF.c.1362	11.775
10	Me.MEF.c.1658	45.249	11	Me.MEF.c.1361	11.775
10	Me.MEF.c.1597	50.22	11	Me.MEF.c.2120	18.023
10	Me.MEF.c.1664	56.495	11	Me.MEF.c.1513	19.486
10	Me.MEF.c.3240	63.732	11	Me.MEF.c.1833	20.912
10	Me.MEF.c.3242	63.732	11	Me.MEF.c.0055	25.307
10	Me.MEF.c.3241	63.732	11	Me.MEF.c.0053	25.307
10	Me.MEF.c.2769	65.105	11	Me.MEF.c.3340	26.734
10	Me.MEF.c.2770	65.105	11	Me.MEF.c.2435	40.417
10	Me.MEF.c.0063	76.637	11	Me.MEF.c.2470	42.753
10	Me.MEF.c.3002	86.595	11	Me.MEF.c.2472	42.753
10	Me.MEF.c.2171	91.281	11	Me.MEF.c.2471	42.753
10	Me.MEF.c.0271	102.194	11	Me.MEF.c.1162	42.902
10	Me.MEF.c.2425	102.194	11	Me.MEF.c.1161	42.902
10	Me.MEF.c.1150	119.845	11	Me.MEF.c.0405	64.186
10	Me.MEF.c.2366	133.044	11	Me.MEF.c.0387	64.574
10	Me.MEF.c.2368	133.044	11	Me.MEF.c.2486	68.897
10	Me.MEF.c.1730	151.388	12	Me.MEF.c.0126	0.000
12	Me.MEF.c.1867	2.989	13	Me.MEF.c.1186	6.342
12	Me.MEF.c.2823	3.481	13	Me.MEF.c.2639	7.698
12	Me.MEF.c.2821	3.481	13	Me.MEF.c.2285	8.146
12	Me.MEF.c.2999	5.19	13	Me.MEF.c.2283	8.816
12	Me.MEF.c.0508	5.612	13	Me.MEF.c.2334	18.985
12	Me.MEF.c.1137	0.000	13	Me.MEF.c.0817	18.985
12	Me.MEF.c.1450	8.233	13	Me.MEF.c.3156	32.398
12	Me.MEF.c.0898	8.238	13	Me.MEF.c.1074	0.000
12	Me.MEF.c.1271	13.502	13	Me.MEF.c.0478	7.409
12	Me.MEF.c.0118	15.465	13	Me.MEF.c.2226	10.443
12	Me.MEF.c.0961	21.391	13	Me.MEF.c.2401	17.115
12	Me.MEF.c.1341	21.391	13	Me.MEF.c.0461	18.456
12	Me.MEF.c.2548	23.101	13	Me.MEF.c.0830	18.456
12	Me.MEF.c.2549	23.101	13	Me.MEF.c.1802	19.733
12	Me.MEF.c.1309	0.000	13	Me.MEF.c.1803	19.733
12	Me.MEF.c.0994	5.263	14	Me.MEF.c.2404	0.000
12	Me.MEF.c.0611	6.707	14	Me.MEF.c.0153	29.957
12	Me.MEF.c.0189	65.489	14	Me.MEF.c.1061	63.251
12	Me.MEF.c.3141	65.489	14	Me.MEF.c.2744	64.115
12	Me.MEF.c.1828	68.133	14	Me.MEF.c.1387	64.115
12	Me.MEF.c.2803	68.757	14	Me.MEF.c.1912	81.257
12	Me.MEF.c.2032	78.011	14	Me.MEF.c.2831	81.257
13	Me.MEF.c.2273	0.000	14	Me.MEF.c.2065	93.589

Appendix1.Continued

Linkage group	SNP Markers	Distance in cM	Linkage group	SNP Markers	Distance in cM
13	Me.MEF.c.3245	1.049	14	Me.MEF.c.2066	93.589
13	Me.MEF.c.2001	1.049	14	Me.MEF.c.2359	94.011
13	Me.MEF.c.1011	4.979	14	Me.MEF.c.0980	102.974
14	Me.MEF.c.2128	112.379	16	Me.MEF.c.1372	17.122
14	Me.MEF.c.0975	123.713	16	Me.MEF.c.2282	23.885
14	Me.MEF.c.0593	126.31	16	Me.MEF.c.2281	23.885
14	Me.MEF.c.1985	134.518	17	Me.MEF.c.2928	0.000
14	Me.MEF.c.0782	137.563	17	Me.MEF.c.3201	16.238
14	Me.MEF.c.2122	141.129	17	Me.MEF.c.2953	47.2
15	Me.MEF.c.0787	0.000	17	Me.MEF.c.1631	48.82
15	Me.MEF.c.3094	0.854	17	Me.MEF.c.3259	51.786
15	Me.MEF.c.0789	1.276	17	Me.MEF.c.3189	63.199
15	Me.MEF.c.0150	4.307	17	Me.MEF.c.0597	63.621
15	Me.MEF.c.0149	4.307	17	Me.MEF.c.2399	63.621
15	Me.MEF.c.1054	8.244	17	Me.MEF.c.2799	63.621
15	Me.MEF.c.1306	11.73	17	Me.MEF.c.2036	63.949
15	Me.MEF.c.0587	13.009	17	Me.MEF.c.2038	63.949
15	Me.MEF.c.1447	14.286	17	Me.MEF.c.0014	64.047
15	Me.MEF.c.3023	14.708	18	Me.MEF.c.1128	0.000
15	Me.MEF.c.3021	15.13	18	Me.MEF.c.1099	4.403
15	Me.MEF.c.1071	16.406	18	Me.MEF.c.0195	7.646
15	Me.MEF.c.0888	16.845	18	Me.MEF.c.0194	7.646
16	Me.MEF.c.0966	0.000	18	Me.MEF.c.0060	10.678
16	Me.MEF.c.1613	1.744	18	Me.MEF.c.0602	11.954
16	Me.MEF.c.0270	2.413	18	Me.MEF.c.3285	13.664
16	Me.MEF.c.0996	2.835	18	Me.MEF.c.1075	14.088
16	Me.MEF.c.2815	6.349	19	Me.MEF.c.1302	0.000
16	Me.MEF.c.1527	7.223	19	Me.MEF.c.0227	0.000
16	Me.MEF.c.3054	10.266	19	Me.MEF.c.1399	0.24
19	Me.MEF.c.2402	14.05	20	Me.MEF.c.2497	4.458
19	Me.MEF.c.2265	28.675	20	Me.MEF.c.0871	5.305
19	Me.MEF.c.2878	37.673	20	Me.MEF.c.0869	5.305
20	Me.MEF.c.2304	0.000	20	Me.MEF.c.3066	10.273

Appendix 2: Protocol for DNA extraction from cassava leaves

DNA of plants, be it nuclear DNA or cytoplasmic DNA, needs to be separated from all other plant cell components before it can be used for cloning and DNA fingerprinting. The methods given below describe step-by-step how DNA is isolated from plant tissue sampled from cassava.

Cassava (*Manihot esculenta* Crantz)

Miniprep DNA extraction protocol [modified Dellaporte (1983)]

Materials:

1. Young leaf lobe or half of a mature leaf (0.12-0.2g)
2. Liquid Nitrogen
3. Pestles and mortars
4. Eppendorf tubes (1.5 ml)
5. Eppendorf tubes (2 ml)
6. Water-bath (37°C - 65°C)
7. Table top Eppendorf centrifuge

Reagents:

Extraction Buffer (1litre)

100 mM Tris-HCl (100 ml of 1 M Tris-HCl, pH 8.0)

50 mM EDTA (100 ml of 0.5 M EDTA, pH 8.0)

500 mM NaCl (100 ml of 5 M NaCl)

Make up to 950ml with de-ionized water and adjust to pH 8.0 using HCl. Autoclave for 15min. Add 1% (w/v) PVP (40,000 MW), dissolve by mixing and adjust total volume to 1 litre with de-ionized water. Just before use add 700µl of β-mercaptoethanol.

*Should store for up to one month only.

Note. When working with β -mercaptoethanol, use the fume cupboard.

- 20% (w/v) SDS
- 5M potassium acetate
- iso-propanol (stored at -20°C)

TE buffer I (1 litre)

50 mM Tris-HCl (50 ml of 1 M Tris-HCl, pH 8.0)

10 mM EDTA (20 ml of 0.5 M EDTA, pH 8.0)

Make up to 950ml with de-ionized water and adjust to pH 8.0 using HCl and adjust total volume to 1 litre.

TE buffer II, containing 10mg/ml RNaseA (1 litre)

10 mM Tris-HCl (10 ml of 1 M Tris-HCl, pH 8.0)

1 mM EDTA (2 ml of 0.5 M EDTA, pH 8.0)

Make up to 950ml with de-ionized water and adjust to pH 8.0 using HCl and adjust total volume to 1 litre. Estimate amount of buffer you'll need and add 10mg/ml RNaseA to the volume of low salt TE needed.

Phenol:chloroform: isoamylalcohol (25:24:1) (100 ml)

equilibrated phenol (50 ml)

chloroform (48 ml)

isoamylalcohol (2 ml)

When working with phenol, use the fume cupboard.

chloroform: isoamylalcohol (24:1) (100 ml)

chloroform (96 ml)

isoamylalcohol (4 ml)

ethanol:sodiumacetate (31.5 ml)

30 ml ethanol (absolute) (30 ml)

3 M sodiumacetate (NaOAc) (pH 5.2) (1.5 ml)

70% Ethanol (stored at -20°C)

Ethanol (absolute) 70 ml, adjust to 100 ml with double distilled water.

PVP extraction

1. Harvest one young leaf lobe or half of a mature leaf, approximately 0.15 – 0.2 g; grind freshly harvested leaves with liquid nitrogen with a pestle and mortar
2. Transfer to a frozen 2ml eppendorf tube, using a frozen spatula
3. Add 800 μ l of Extraction buffer, at 65°C, and 50 μ l of 20% SDS (Do not handle more than 36 eppendorf tubes)
4. Shake vigorously until the tissue becomes dispersed in the buffer; continue to mix for another 1 min.
5. Transfer to 65°C and incubate for 15 min with vortex intermittently 5-6 times
6. Remove tubes from 65°C and allow them to cool to room temp, takes approximately 2min.

Precipitation of Proteins and Polysaccharides

1. Add 250 μ l of ice-cold 5 M Potassium Acetate mix by gently inverting 5-6 times
2. Incubate on ice for 20 min.
3. Centrifuge at 12,000 rpm in eppendorf centrifuge for 10 min.
4. Transfer supernatant to a new 2 ml eppendorf tube.

Crude DNA pellet precipitation and RNase treatment

1. Add one volume of ice-cold iso-propanol (approx. 1000 μ l), and mix by inverting gently 8-10 times
2. Incubate at -80°C for 1 h, and centrifuge at 12,000 rpm for 10 min.
3. Pour off supernatant, and remove last drops of isopropanol by placing face down on paper towels
4. Re-suspend pellet in 500 μ l of 50 mM Tris-HCl/10 mM EDTA, incubating at 65°C is helpful for 10 to 15 min with constant gentle shaking is helpful.
5. Transfer to a 1.5ul eppendorf tube
6. Add one volume of ice-cold iso-propanol (500 μ l) and mix by inverting gently 8-10 times
7. Incubate at -80°C for 1 h, and centrifuge at 12,000 rpm for 10 min.
8. Pour off supernatant, and remove last drops of iso-propanol by placing face down on paper towels. Allow pellet to dry by leaving it on the paper towels for another hour

9. Add 100-200ul of 10mM Tris-HCl/1 mM EDTA, containing 100ug/ml RNaseA, depending on the size of the pellet. Dissolve the pellet and store tube at room temperature overnight to dissolve pellet, or incubate at 37°C for 30 min.

Solvent extraction

1. Add 200 µl phenol: chlorophorm:isoamylalcohol (25:24:1) to each sample and invert twice to mix
2. Centrifuge tubes at 12,000 rpm for 10 minutes
3. Transfer a fixed volume of 180 µl to a fresh eppendorf tube
4. Add 200 µl chlorophorm: isoamylalcohol (24:1) to each sample and invert twice to mix
5. Centrifuge tubes at 12,000 rpm for 10 minutes
6. Transfer a fixed volume of aqueous layer (approximately 180 µl) to a fresh eppendorf tube. Make sure you do not disturb the interface layer as this is where proteins, polyphenolics and polysaccharides are lurking! If you are worried about losing too much DNA, once you have removed the supernatant, you could add a further 100ul of 10 mM Tris-HCl/1 mM EDTA, and centrifuge again at 12,000 rpm for 10 minutes and again remove 80ul of supernatant to the same tube.

Purification

1. Add 315µl ethanol: sodiumacetate solution to each sample and place in -20°C for 5 min.
2. Centrifuge tubes at 12,000 rpm for 5 minutes
3. Decant supernatant from each sample and wash pellet with 200 µl 70% Ethanol to each tube
4. Centrifuge tubes at 12,000 rpm for 5 minutes
5. Optional: repeat wash-step with 70% Ethanol
6. Decant supernatant from each sample and air-dry pellet for approximately 1 hr
Re-suspend pellet in 100 µl low-salt TE buffer and store at 4°C

Appendix 3: DNA qualification, quantification and dilution to 50ng/μl for working samples

NCAR sample ID	ng/μl	260/280	260/230	DNA added μl	Water added μl	NCAR sample ID	ng/μl	260/280	260/230	DNA added μl	Water added μl
1	53.84	1.71	1.27	92.87	7.13	23	1082.96	1.86	1.85	4.62	95.38
2	112.74	1.76	1.73	44.35	55.65	24	281.58	1.79	2.04	17.76	82.24
3	291.31	1.65	1.08	17.16	82.84	25	99.28	1.67	1.55	50.36	49.64
4	511.04	1.81	1.76	9.78	90.22	26	226.37	1.81	1.81	22.09	77.91
5	1076.95	1.75	1.98	4.64	95.36	27	164.87	1.80	1.95	30.33	69.67
6	816.76	1.88	1.82	6.12	93.88	28	638.47	1.87	1.68	7.83	92.17
7	350.29	1.73	1.38	14.27	85.73	29	705.30	1.75	1.27	7.09	92.91
8	565.58	1.82	1.83	8.84	91.16	31	826.55	1.95	1.83	6.05	93.95
9	222.16	1.82	1.69	22.51	77.49	32	169.74	1.80	1.91	29.46	70.54
10	301.04	1.82	1.75	16.61	83.39	33	85.31	1.71	1.76	58.61	41.39
11	433.28	1.89	2.25	11.54	88.46	34	193.70	1.80	2.00	25.81	74.19
12	949.00	1.95	1.99	5.27	94.73	35	341.16	1.79	1.92	14.66	85.34
13	453.49	1.89	2.04	11.03	88.97	36	201.89	1.83	2.03	24.77	75.23
14	497.05	1.85	2.20	10.06	89.94	37	580.71	1.87	2.03	8.61	91.39
15	789.73	1.91	1.98	6.33	93.67	38	580.84	1.84	2.02	8.61	91.39
16	230.24	1.85	2.02	21.72	78.28	39	13.35	1.59	1.36	374.53	-274.53
17	756.78	1.77	1.73	6.61	93.39	41	315.72	1.83	2.00	15.84	84.16
18	469.45	1.90	2.25	10.65	89.35	43	408.28	1.79	1.83	12.25	87.75
19	859.52	1.87	1.79	5.82	94.18	44	5.18	1.68	0.53	965.25	-865.25
20	859.26	1.92	1.82	5.82	94.18	45	29.52	1.76	1.47	169.38	-69.38
21	92.48	1.90	1.87	54.07	45.93	46	535.64	1.79	2.09	9.33	90.67
22	281.10	1.84	1.91	17.79	82.21	47	100.49	1.84	2.08	49.76	50.24
56	326.27	1.87	1.96	15.32	84.68	82	217.58	1.87	2.12	22.98	77.02
57	136.32	1.85	1.81	36.68	63.32	83	295.15	1.85	1.98	16.94	83.06
58	162.86	1.71	1.80	30.70	69.30	84	203.70	1.86	2.01	24.55	75.45
59	16.89	1.65	1.22	296.03	-196.03	85	158.79	1.89	2.23	31.49	68.51

Appendix3. Continued

CAR						NCAR					
sample ID	ng/μl	260/280	260/230	DNA added μl	Water added μl	sample ID	ng/μl	260/280	260/230	DNA added μl	Water added μl
60	289.26	1.82	1.60	17.29	82.71	86	215.09	1.85	1.95	23.25	76.75
61	277.89	1.83	1.92	17.99	82.01	87	181.18	1.91	1.99	27.60	72.40
62	72.92	1.80	2.04	68.57	31.43	88	262.30	1.86	2.19	19.06	80.94
63	100.64	1.85	1.76	49.68	50.32	89	162.67	1.82	1.89	30.74	69.26
64	44.19	1.83	2.09	113.15	-13.15	90	415.52	1.82	2.01	12.03	87.97
65	108.51	1.78	1.56	46.08	53.92	91	376.75	1.80	1.94	13.27	86.73
66	170.86	1.83	1.84	29.26	70.74	92	48.72	1.76	1.87	102.63	-2.63
67	256.38	1.75	1.68	19.50	80.50	93	410.75	1.82	2.04	12.17	87.83
68	235.19	1.86	1.96	21.26	78.74	94	347.35	1.81	2.03	14.39	85.61
69	420.01	1.82	2.00	11.90	88.10	95	201.62	1.82	2.09	24.80	75.20
70	360.68	1.81	2.14	13.86	86.14	96	226.25	1.86	2.13	22.10	77.90
71	298.64	1.75	1.76	16.74	83.26	97	234.35	1.86	2.09	21.34	78.66
72	105.14	1.81	1.40	47.56	52.44	98	502.39	1.80	1.98	9.95	90.05
73	105.66	1.89	1.90	47.32	52.68	99	40.16	1.75	1.72	124.50	-24.50
100	13.61	1.56	1.23	367.38	-267.38	125	300.38	1.87	2.29	16.65	83.35
101	276.22	1.84	2.03	18.10	81.90	127	2379.13	1.92	2.11	2.10	97.90
102	442.60	1.80	2.04	11.30	88.70	128	187.08	1.77	2.10	26.73	73.27
103	243.44	1.83	1.84	20.54	79.46	129	436.42	1.85	2.16	11.46	88.54
104	443.97	1.80	2.05	11.26	88.74	130	365.94	1.83	2.05	13.66	86.34
105	276.52	1.85	2.07	18.08	81.92	131	154.74	1.83	1.70	32.31	67.69
106	88.09	1.88	1.33	56.76	43.24	133	289.02	1.87	2.08	17.30	82.70
107	140.25	1.88	2.05	35.65	64.35	134	187.63	1.89	2.23	26.65	73.35
108	291.67	1.70	1.28	17.14	82.86	135	194.79	1.87	1.98	25.67	74.33
109	134.03	1.91	2.00	37.31	62.69	136	249.42	1.87	2.22	20.05	79.95

Appendix3. Continued

NCAR Sample ID	ng/μl	260/280	260/230	DNA added μl	Water added μl	NCAR Sample ID	ng/μl	260/280	260/230	DNA added μl	Water added μl
110	114.34	1.69	1.46	43.73	56.27	138	235.89	1.89	2.27	21.20	78.80
111	59.56	1.81	0.93	83.95	16.05	139	453.98	1.85	1.89	11.01	88.99
112	139.74	1.87	2.03	35.78	64.22	144	716.30	1.77	1.33	6.980	93.02
113	3.96	1.30	1.84	1262.63	-1162.63	153	1498.55	1.72	1.63	3.34	96.66
114	188.97	1.82	1.81	26.46	73.54	157	81.14	1.59	0.88	61.62	38.38
115	444.07	1.82	2.05	11.26	88.74	166	473.49	1.64	1.19	10.56	89.44
116	175.68	1.89	2.16	28.46	71.54	176	263.42	1.81	1.64	18.98	81.02
117	5.68	1.81	1.10	880.28	-780.28	178	151.27	1.61	1.05	33.05	66.95
118	1238.87	1.74	1.41	4.04	95.96	181	529.82	1.73	1.50	9.44	90.56
119	179.73	1.86	2.14	27.82	72.18	182	1101.82	1.96	1.80	4.54	95.46
120	424.14	1.85	2.00	11.79	88.21	184	425.16	1.78	1.58	11.76	88.24
121	390.80	1.85	1.89	12.79	87.21	185	714.60	1.81	1.23	7.00	93.00
122	419.40	1.85	2.10	11.92	88.08	187	1161.44	1.87	1.35	4.31	95.69
123	313.50	1.84	1.94	15.95	84.05	211	495.72	1.74	1.63	10.09	89.91
124	288.15	1.87	2.23	17.35	82.65	212	417.19	1.76	1.81	11.98	88.02
214	319.38	1.82	1.68	15.66	84.34	255	1007.51	1.79	1.71	4.96	95.04
215	670.86	1.78	1.53	7.45	92.55	256	440.41	1.73	1.68	11.35	88.65
226	403.51	1.76	1.71	12.39	87.61	257	2198.79	1.75	2.22	2.27	97.73
227	667.32	1.71	1.35	7.49	92.51	258	414.69	1.76	1.85	12.06	87.94
229	411.76	1.76	1.38	12.14	87.86	260	208.71	1.68	2.12	23.96	76.04
234	558.60	1.74	1.85	8.95	91.05	264	285.35	1.77	1.51	17.52	82.48
234	627.77	1.74	1.33	7.96	92.04	268	277.58	1.78	1.59	18.01	81.99
235	303.16	1.67	1.07	16.49	83.51	273	319.40	1.68	1.48	15.65	84.35
236	95.81	1.71	1.24	52.19	47.81	274	673.87	1.66	1.50	7.42	92.58
237	516.45	1.72	1.63	9.68	90.32	277	468.42	1.75	1.83	10.67	89.33
238	1541.98	1.66	1.85	3.24	96.76	279	167.54	1.68	1.70	29.84	70.16

Appendix3. Continued

NCAR Sample ID	ng/μl	260/280	260/230	DNA added μl	Water added μl	NCAR Sample ID	ng/μl	260/280	260/230	DNA added μl	Water added μl
239	375.63	1.74	1.42	13.31	86.69	280	421.29	1.74	1.63	11.87	88.13
241	443.68	1.72	1.39	11.27	88.73	285	1484.00	1.69	2.17	3.37	96.63
242	540.72	1.72	1.49	9.25	90.75	287	395.49	1.82	2.07	12.64	87.36
243	126.81	1.59	1.37	39.43	60.57	290	114.93	1.71	1.15	43.50	56.50
245	169.56	1.78	1.39	29.49	70.51	291	687.08	1.82	1.49	7.28	92.72
246	3680.59	1.79	1.58	1.36	98.64	292	458.19	1.79	1.76	10.91	89.09
247	335.90	1.74	1.48	14.89	85.11	293	228.90	1.71	1.20	21.84	78.16
248	319.50	1.68	1.19	15.65	84.35	295	281.05	1.77	1.46	17.79	82.21
249	371.34	1.75	1.59	13.46	86.54	296	57.84	1.65	1.58	86.45	13.55
250	3187.49	1.82	1.78	1.57	98.43	297	101.34	1.77	1.41	49.34	50.66
251	112.63	1.74	1.81	44.39	55.61	298	169.87	1.65	0.99	29.43	70.57
252	298.47	1.83	1.57	16.75	83.25	300	434.28	1.75	1.44	11.51	88.49
253	1746.64	1.89	1.83	2.86	97.14	301	188.33	1.69	1.03	26.55	73.45
254	93.05	1.70	1.04	53.73	46.27	302	293.50	1.73	1.35	17.04	82.96
303	782.90	1.72	1.07	6.39	93.61	335	318.27	1.72	1.92	15.71	84.29
304	171.02	1.71	1.17	29.24	70.76	336	502.86	1.70	1.50	9.94	90.06
305	178.43	1.72	1.24	28.02	71.98	337	351.03	1.79	1.84	14.24	85.76
306	252.73	1.75	1.39	19.78	80.22	338	138.63	1.71	1.39	36.07	63.93
307	149.27	1.72	1.43	33.50	66.50	339	266.38	1.78	1.87	18.77	81.23
311	164.72	1.79	1.44	30.35	69.65	340	1122.59	1.86	1.53	4.45	95.55
313	267.18	1.75	1.27	18.71	81.29	341	263.35	1.73	1.57	18.99	81.01
314	405.07	1.70	1.37	12.34	87.66	343	153.19	1.72	1.25	32.64	67.36
315	94.54	1.78	1.26	52.89	47.11	344	397.34	1.70	1.37	12.58	87.42
316	665.55	1.78	1.19	7.51	92.49	345	250.35	1.71	1.31	19.97	80.03
317	130.70	1.67	1.23	38.26	61.74	346	101.17	1.76	1.93	49.42	50.58
318	160.75	1.62	1.08	31.10	68.90	347	1044.26	1.88	1.41	4.79	95.21

Appendix3. Continued

NCAR Sample ID	ng/μl	260/280	260/230	DNA added μl	Water added μl	NCAR Sample ID	ng/μl	260/280	260/230	DNA added μl	Water added μl
320	323.54	1.78	1.69	15.45	84.55	349	576.66	1.72	1.59	8.67	91.33
323	231.96	1.71	1.27	21.56	78.44	352	702.70	1.91	1.45	7.12	92.88
324	263.40	1.77	1.73	18.98	81.02	353	1250.42	1.91	1.57	4.00	96.00
325	286.41	1.76	1.53	17.46	82.54	354	286.36	1.81	1.70	17.46	82.54
326	299.97	1.79	1.69	16.67	83.33	355	450.57	1.76	1.58	11.10	88.90
327	214.43	1.87	1.85	23.32	76.68	356	237.76	1.75	1.34	21.03	78.97
328	229.91	1.71	1.24	21.75	78.25	357	1038.81	1.96	1.68	4.81	95.19
329	265.93	1.75	1.47	18.80	81.20	358	548.07	1.73	1.50	9.12	90.88
331	187.45	1.75	1.44	26.67	73.33	359	517.64	1.75	1.65	9.66	90.34
332	649.62	1.88	1.35	7.70	92.30	360	437.17	1.72	1.40	11.44	88.56
333	317.76	1.75	1.45	15.74	84.26	361	436.00	1.76	1.47	11.47	88.53
378	118.53	1.82	1.96	42.18	57.82	384	757.54	1.87	1.26	6.60	93.40
379	580.36	1.74	1.77	8.62	91.38	385	478.89	1.78	1.61	10.44	89.56
380	398.53	1.77	1.84	12.55	87.45	386	457.03	1.78	1.60	10.94	89.06
381	420.15	1.81	1.95	11.90	88.10	387	838.70	1.82	1.37	5.96	94.04
382	274.88	1.76	1.64	18.19	81.81	388	852.79	1.84	1.34	5.86	94.14
383	151.17	1.84	1.98	33.08	66.92	390	462.35	1.70	1.36	10.81	89.19

NACHINYAYA



Plate 6: Nachinyaya (CBSD tolerant) genotype showing no CBSD leaf symptoms

AR37 - 80



Plate 7:AR37-80 (CBSD susceptible) genotype showing CBSD leaf symptoms